

Genesis OA (GO) Horizontal Series Dedicated Outdoor Air System

Submittal Data Models GO H05 - 99 Models GO R03 - 99 60Hz - R22

English Language/I-P Units

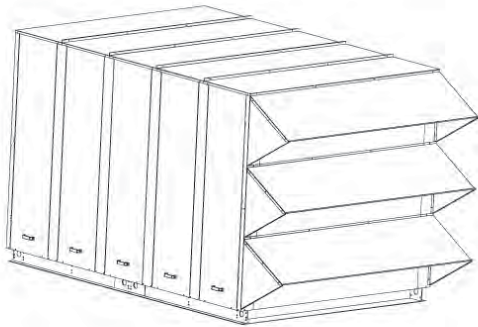

Rev.: 4 June, 2009B



SUBMITTAL DATA - I-P UNITS

Unit Designation: _____

Job Name: _____

Architect: _____

Engineer: _____

Contractor: _____

PERFORMANCE DATA

Moisture Removal: _____ lbs/hr

Design Cooling Capacity: _____ Btuh

Design EER: _____

Design Heating Capacity: _____ Btuh

Design COP: _____

Design Outdoor Air Temp (Clg): _____ DB/WB

Design Dewpoint: _____ °F

Design Entering Water Temp (Clg): _____ °F

Design Indoor Air Temp (Clg): _____ DB/WB

Design Outdoor Air Temp (Htg): _____ DB/WB

Design Entering Water Temp (Htg): _____ °F

Design Indoor Air Temp (Htg): _____ DB/WB

Design Airflow: _____ CFM

Fan Speed or Motor/RPM/Turns: _____

Operating Weight: _____ (lb)

ELECTRICAL DATA

Power Supply: _____ Volts _____ Phase _____ Hz

Minimum Circuit Ampacity: _____

Maximum Overcurrent Protection: _____

ClimateMaster works continually to improve its products. As a result, the design and specifications of each product at the time of order may be changed without notice and may not be as described herein. Please contact ClimateMaster's Customer Service Department at 1-405-745-6000 for specific information on the current design and specifications. Statements and other information contained herein are not express warranties and do not form the basis of any bargain between the parties, but are merely ClimateMaster's opinion or commendation of its products. The latest version of this document is available at climatemaster.com.



LC512

Rev.: 4 June, 2009B

Genesis OA (GO) Horizontal Series Dedicated Outdoor Air System

Submittal Data Models GO H05 - 99 Models GO R03 - 99 60Hz - R22

English Language/S-I Units

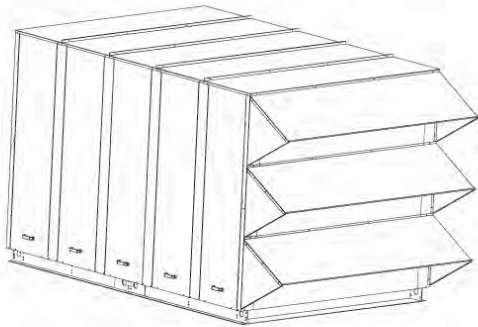

Rev.: 4 June, 2009B



SUBMITTAL DATA - S-I UNITS

Unit Designation: _____

Job Name: _____

Architect: _____

Engineer: _____

Contractor: _____

PERFORMANCE DATA

Moisture Removal: _____ kg/hr

Design Cooling Capacity: _____ kW

Design EER: _____

Design Heating Capacity: _____ kW

Design COP: _____

Design Outdoor Air Temp (Clg): _____ DB/WB

Design Dewpoint: _____ °C

Design Entering Water Temp (Clg): _____ °C

Design Indoor Air Temp (Clg): _____ DB/WB

Design Outdoor Air Temp (Htg): _____ DB/WB

Design Entering Water Temp (Htg): _____ °C

Design Indoor Air Temp (Htg): _____ DB/WB

Design Airflow: _____ l/s

Fan Speed or Motor/RPM/Turns: _____

Operating Weight: _____ (kg)

ELECTRICAL DATA

Power Supply: _____ Volts _____ Phase _____ Hz

Minimum Circuit Ampacity: _____

Maximum Overcurrent Protection: _____

ClimateMaster works continually to improve its products. As a result, the design and specifications of each product at the time of order may be changed without notice and may not be as described herein. Please contact ClimateMaster's Customer Service Department at 1-405-745-6000 for specific information on the current design and specifications. Statements and other information contained herein are not express warranties and do not form the basis of any bargain between the parties, but are merely ClimateMaster's opinion or commendation of its products. The latest version of this document is available at climatemaster.com.



LC512

Rev.: 4 June, 2009B

Table of Contents

	*Page Number
Unit Features	4
Selection Procedure	5
GO Series Nomenclature	6
Horizontal Wheeled Blower Data Models 03 & 05	7
Horizontal Wheeled Blower Data Models 08 & 10	8
Horizontal Wheeled Blower Data Model 15	9
Horizontal Wheeled Blower Data Model 20	10-11
Horizontal Non-Wheeled Blower Data Models 05 & 08	12
Horizontal Non-Wheeled Blower Data Model 10	13
Horizontal Non-Wheeled Blower Data Model 15	14
Horizontal Non-Wheeled Blower Data Model 20	15
Horizontal Non-Wheeled Blower Data Model 25	16
Horizontal Non-Wheeled Blower Data Model 30	17
Horizontal Non-Wheeled Blower Data Model 36	18
Horizontal Non-Wheeled Blower Data Model 40	19-20
Horizontal Non-Wheeled Blower Data Model 46	21-22
Horizontal Non-Wheeled Blower Data Model 50	23-24
Horizontal Non-Wheeled Blower Data Model 56	25-26
Horizontal Non-Wheeled Blower Data Model 60	27-28
Horizontal Non-Wheeled Dimensional Data	29-38
GOHD/RD Physical Data Table	39
GOHW/RW Physical Data Table	40
Blower Motor HP and Blower Wheel Size Table	41
Sequence of Operation	42
Control Features, Selections and Sequence of Operation	43-47
Genesis HD & RD Engineering Specifications	48-50
Genesis HW & RW Engineering Specifications	51-53
Revision History	54

*Document page number is shown next to part number (e.g. LC512 - 3 = page 3). Since not all pages are typically used in the submittals process, the page number in the lower right corner can still be used (page ____ of ____).

ClimateMaster works continually to improve its products. As a result, the design and specifications of each product at the time of order may be changed without notice and may not be as described herein. Please contact ClimateMaster's Customer Service Department at 1-405-745-6000 for specific information on the current design and specifications. Statements and other information contained herein are not express warranties and do not form the basis of any bargain between the parties, but are merely ClimateMaster's opinion or commendation of its products. The latest version of this document is available at climatemaster.com.



CLIMATEMASTER DEDICATED OUTDOOR AIR SYSTEMS - 100% OUTDOOR AIR APPLICATIONS

ClimateMaster Outdoor Air Series dedicated outdoor air systems (DOAS) provide the most complete solution for your applications. Our many options allow you to provide full heating in the winter, incorporate our units into a water loop using our innovative refrigerant circuit design, while also dehumidifying your facility in the summer. Rely on ClimateMaster for total system solutions to your WSHP outdoor air applications.

CLIMATEMASTER'S APPROACH TO IAQ

ISSUES OF INDOOR AIR QUALITY (IAQ)

Several HVAC trade and professional organizations, such as ASHRAE, have documented the need for suitable indoor air quality. A primary requirement for maintaining proper IAQ is the introduction of outdoor air. Unfortunately, outdoor air also introduces moisture into a facility and can create IAQ problems – mold, mildew and the proper environment for viruses and other organisms to flourish. The key to preventing mold formation and growth is to control the relative humidity within the space. However, a standard WSHP cannot achieve this because it is controlled on temperature alone. Instead, a system must be implemented that can provide full control of both temperature and humidity.

OPTIMAL IAQ DESIGN

Several important IAQ issues must be addressed to design the most effective dehumidification system for the application. ClimateMaster reviews the following list of criteria when building all Genesis OA and Tranquility OA Series IAQ units.

DEDICATED OUTDOOR AIR SYSTEMS (DOAS)

The most energy efficient method for removing moisture is to use a dedicated outdoor air system that will reduce the dew point of supply air to below 55°F (13°C). This approach also helps remove existing moisture inside a facility. A DOAS design can also be optimized to remove maximum moisture at the lowest electrical consumption rate (Moisture Removal Efficiency, MRE) at both full and part-load conditions. ClimateMaster supplies DOAS units under our Genesis OA (R-22 refrigerant) and Tranquility OA (R-410A refrigerant) series product lines.

ASHRAE 90.1. The ASHRAE Building Code 90.1 establishes a standard for energy conservation of commercial HVAC equipment. It states that some systems cannot use new energy to reheat the air; rather, 75% of their energy must be site-recovered.

ClimateMaster's Genesis OA and Tranquility OA series units comply with, and exceeds, this code by using hot gas reheat coils.

LEAVING AIR TEMPERATURE CONTROL

ClimateMaster's IAQ units provide precise discharge temperature by using fully modulating hot gas control valves. Other systems that use solenoid valves and/or liquid sub-cooling loops can control the leaving air temperature to only $\pm 10^{\circ}\text{F}$ ($\pm 6^{\circ}\text{C}$) and typically are closer to $\pm 20^{\circ}\text{F}$ ($\pm 11^{\circ}\text{C}$). These systems do not comply with code 90.1. They require new energy to trim the leaving air temperature to avoid overcooling of the space.

This lack of accuracy also directly affects operation costs. Costs rise when new energy is required to adjust high temperature fluctuations in order to meet preset temperatures. Table 1 below shows the potential increase in energy consumption that can occur at different control accuracies. In addition, people can sense temperature differences greater than $\pm 2.0^{\circ}\text{F}$ ($\pm 1.0^{\circ}\text{C}$). Therefore, the greater the temperature swing, the more uncomfortable the occupants will be (see Figure 1).

AIR SEPARATED COILS

If a hot gas reheat coil is installed too close to the evaporator coil, re-hydration can occur. Water that forms on the evaporator coil can be blown onto the hot reheat coil, and thus be converted back into vapor and returned to the space. This completely negates all dehumidification efforts and fails to meet basic IAQ design requirements. Plus, the system ends up removing less moisture at a higher electrical cost. That's why we design our IAQ units with adequate separation between the outlet face of the evaporator coil and the inlet face of the hot gas reheat to prevent re-hydration (see Figure 2).

FILTRATION

Outdoor air is full of many airborne particles and pollutants. Filtration is essential to prevent dirt from accumulating on coils and contaminating indoor spaces. When 1- or 2-inch wide (25 or 51 mm) filters are used, they must be frequently replaced. Therefore, our IAQ units are equipped with a minimum of 4-inch (102 mm), pleated filters to reduce filter maintenance.

FULL-SIZE CONDENSERS

Our IAQ systems use the ideal control strategy that can provide first-stage cooling by delivering colder air to the space. Since the compressor must be energized for dehumidification, the unit can meet the space's part load sensible requirements. As a result, OA Series units can help reduce the size of the main building air conditioning system. This control is called room or OA reset of LAT.



Selection Procedure

Reference Calculations

Heating	Cooling	
$LWT = EWT - \frac{HE}{GPM \times 500}$	$LWT = EWT + \frac{HR}{GPM \times 500}$	$LC = TC - SC$
$LAT = EAT + \frac{HC}{CFM \times 1.08}$	$LAT (DB) = EAT (DB) - \frac{SC}{CFM \times 1.08}$	$S/T = \frac{SC}{TC}$

Legend and Glossary of Abbreviations

BTUH = BTU(British Thermal Unit) per hour	HWC = hot water generator (desuperheater) capacity, Mbtuh
CFM = airflow, cubic feet/minute	IPT = internal pipe thread
COP = coefficient of performance = BTUH output/BTUH input	KW = total power unit input, kilowatts
DB = dry bulb temperature (°F)	LAT = leaving air temperature, °F
EAT = entering air temperature, Fahrenheit (dry bulb/wet bulb)	LC = latent cooling capacity, BTUH
EER = energy efficiency ratio = BTUH output/Watt input	LWT = leaving water temperature, °F
EPT = external pipe thread	MBTUH = 1000 BTU per hour
ESP = external static pressure (inches w.g.)	S/T = sensible to total cooling ratio
EWT = entering water temperature	SC = sensible cooling capacity, BTUH
GPM = water flow in U.S. gallons/minute	TC = total cooling capacity, BTUH
HE = total heat of extraction, BTUH	WB = wet bulb temperature (°F)
HC = air heating capacity, BTUH	WPD = waterside pressure drop (psi & ft. of hd.)
HR = total heat of rejection, BTUH	

Conversion Table - to convert inch-pound (English) to SI (Metric)

Air Flow	Water Flow	Ext Static Pressure	Water Pressure Drop
Airflow (L/s) = CFM x 0.472	Water Flow (L/s) = gpm x 0.0631	ESP (Pa) = ESP (in of wg) x 249	PD (kPa) = PD (ft of hd) x 2.99

GO Series 60Hz - R22 Submittal Data Eng/I-P



GO Series Nomenclature

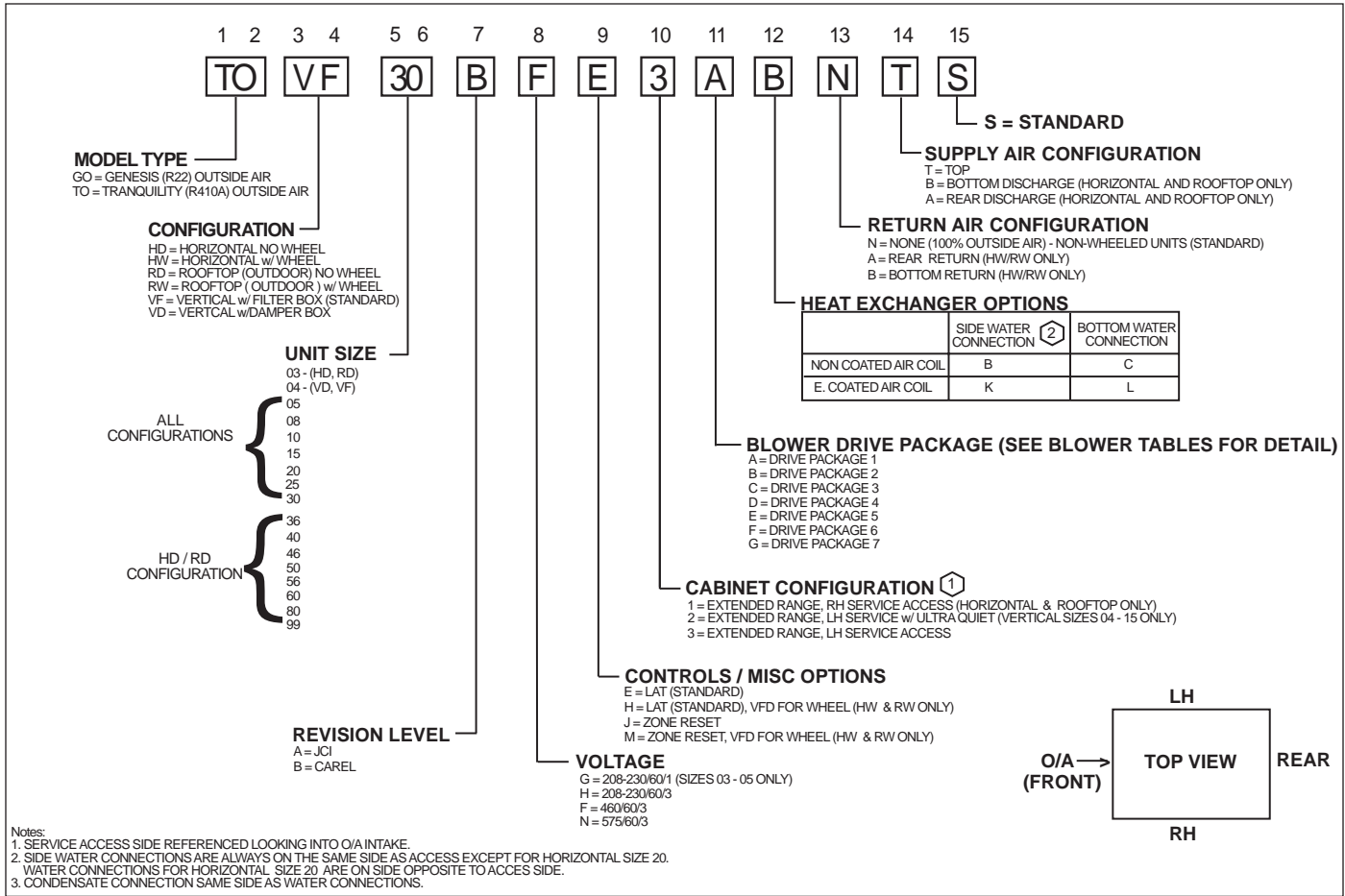

Air Limits	HD/RD Models		HW/RW Models	
	Cooling/Dehumid Mode	Heating Mode	Cooling/Dehumid Mode	Heating Mode
Minimum Ambient Air	40 F [4.4 C]	40 F [4.4 C]	40 F [4.4 C]	-10 F [-23.3 C]
Maximum Ambient Air	100 F [37.8 C]	100 F [37.8 C]	100 F [37.8 C]	100 F [37.8 C]
Minimum Entering Air	50 F [10.0 C]	15 F [-9.4 C]	50 F [10.0 C]	-10 F [-23.3 C]
Maximum Entering Air	110 F [43 C]	80 F [26.7]	110 F [43 C]	80 F [26.7]
Water Limits				
Minimum Entering Water	35 F [1.7 C]	35 F [1.7 C]	35 F [1.7 C]	35 F [1.7 C]
Maximum Entering Water	105 F [1.7 C]	90 F [32.2 C]	105 F [1.7 C]	90 F [32.2 C]



**Horizontal Wheeled Blower Data
Model 03**

Airflow	03 - With Wheel			
CFM	ESP 0.5"	ESP 1"	ESP 1.5"	ESP 2"
891	A	A	A	B
900	A	A	A	B
950	A	A	B	B
1000	A	A	B	C
1050	A	B	B	C
1100	A	B	B	C
1150	A	B	B	C
1200	B	B	B	C
1250	B	B	C	C
1300	B	B	C	C
1350	B	C	C	C
1400	B	C	C	C
1450	B	C	C	C
1500	C	C	C	C
THROUGH				
1622	C	C	C	C

**Horizontal Wheeled Blower Data
Model 05**

Airflow	05 - With Wheel			
CFM	ESP 0.5"	ESP 1"	ESP 1.5"	ESP 2"
1523	A	A	B	B
1550	A	A	B	B
1600	A	A	B	B
1650	A	A	B	B
1700	A	B	B	B
1750	A	B	B	B
1800	A	B	B	C
1850	B	B	B	C
1900	B	B	B	C
1950	B	B	C	C
2000	B	B	C	C
2050	B	B	C	C
2100	B	C	C	C
2150	B	C	C	C
2200	B	C	C	C
2250	C	C	C	C
THROUGH				
2767	C	C	C	C

ClimateMaster works continually to improve its products. As a result, the design and specifications of each product at the time of order may be changed without notice and may not be as described herein. Please contact ClimateMaster's Customer Service Department at 1-405-745-6000 for specific information on the current design and specifications. Statements and other information contained herein are not express warranties and do not form the basis of any bargain between the parties, but are merely ClimateMaster's opinion or commendation of its products. The latest version of this document is available at climatemaster.com.

GO Series 60Hz - R22 Submittal Data Eng/I-P



Horizontal Wheeled Blower Data Model 08

Airflow	08 - With Wheel			
CFM	ESP 0.5"	ESP 1"	ESP 1.5"	ESP 2"
2069	B	B	C	C
2100	B	B	C	C
2150	B	B	C	C
2200	B	B	C	C
2250	B	C	C	C
2300	B	C	C	C
2350	B	C	C	C
2400	B	C	C	C
2450	C	C	C	C
THROUGH				
3767	C	C	C	C

Horizontal Wheeled Blower Data Model 10

Airflow	10 - With Wheel			
CFM	ESP 0.5"	ESP 1"	ESP 1.5"	ESP 2"
2697	A	A	B	B
2700	A	A	B	B
2750	A	A	B	B
2800	A	A	B	B
2850	A	A	B	B
2900	A	B	B	B
2950	A	B	B	B
3000	A	B	B	C
3050	A	B	B	C
3100	B	B	B	C
3150	B	B	B	C
3200	B	B	C	C
3250	B	B	C	C
3300	B	B	C	C
3350	B	B	C	C
3400	B	C	C	C
3450	B	C	C	C
3500	B	C	C	C
3550	C	C	C	C
THROUGH				
4913	C	C	C	C



Horizontal Wheeled Blower Data Model 15

Airflow	15 - With Wheel			
CFM	ESP 0.5"	ESP 1"	ESP 1.5"	ESP 2"
3882	A	A	B	B
3900	A	A	B	B
3950	A	A	B	B
4000	A	A	B	B
4050	A	A	B	B
4100	A	A	B	B
4150	A	A	B	B
4200	A	A	B	B
4250	A	A	B	B
4300	A	B	B	B
4350	A	B	B	B
4400	A	B	B	B
4450	A	B	B	B
4500	A	B	B	B
4550	A	B	B	B
4600	A	B	B	B
4650	A	B	B	B
4700	A	B	B	B
4750	A	B	B	B
4800	B	B	B	B
4850	B	B	B	B
4900	B	B	B	B
4950	B	B	B	B
5000	B	B	B	B
5050	B	B	B	C
5100	B	B	B	C
5150	B	B	B	C
5200	B	B	B	C
5250	B	B	B	C
5300	B	B	B	C
5350	B	B	B	C
5400	B	B	C	C
5450	B	B	C	C
5500	B	B	C	C
5550	B	B	C	C
5600	B	B	C	C
5650	B	B	C	C
5700	B	B	C	C
5750	B	C	C	C
5800	B	C	C	C
5850	B	C	C	C
5900	B	C	C	C
5950	B	C	C	C
6000	B	C	C	C
6050	B	C	C	C
6100	C	C	C	C
THROUGH				
7094	C	C	C	C

ClimateMaster works continually to improve its products. As a result, the design and specifications of each product at the time of order may be changed without notice and may not be as described herein. Please contact ClimateMaster's Customer Service Department at 1-405-745-6000 for specific information on the current design and specifications. Statements and other information contained herein are not express warranties and do not form the basis of any bargain between the parties, but are merely ClimateMaster's opinion or commendation of its products. The latest version of this document is available at climatemaster.com.

GO Series 60Hz - R22 Submittal Data Eng/I-P



Horizontal Wheeled Blower Data Model 20

Airflow CFM	20 - With Wheel			
	ESP 0.5"	ESP 1"	ESP 1.5"	ESP 2"
5517	A	A	A	A
5550	A	A	A	A
5600	A	A	A	A
5650	A	A	A	A
5700	A	A	A	A
5750	A	A	A	A
5800	A	A	A	A
5850	A	A	A	A
5900	A	A	A	B
5950	A	A	A	B
6000	A	A	A	B
6050	A	A	A	B
6100	A	A	A	B
6150	A	A	A	B
6200	A	A	A	B
6250	A	A	A	B
6300	A	A	A	B
6350	A	A	A	B
6400	A	A	B	B
6450	A	A	B	B
6500	A	A	B	B
6550	A	A	B	B
6600	A	A	B	B
6650	A	A	B	B
6700	A	A	B	B
6750	A	A	B	B
6800	A	A	B	B
6850	A	B	B	B
6900	A	B	B	B
6950	A	B	B	B
7000	A	B	B	B
7050	A	B	B	B
7100	A	B	B	B
7150	A	B	B	B
7200	A	B	B	B
7250	A	B	B	B
7300	B	B	B	B
7350	B	B	B	B
7400	B	B	B	B
7450	B	B	B	B
7500	B	B	B	B
7550	B	B	B	B
7600	B	B	B	B
7650	B	B	B	B
7700	B	B	B	C
7750	B	B	B	C
7800	B	B	B	C

ClimateMaster works continually to improve its products. As a result, the design and specifications of each product at the time of order may be changed without notice and may not be as described herein. Please contact ClimateMaster's Customer Service Department at 1-405-745-6000 for specific information on the current design and specifications. Statements and other information contained herein are not express warranties and do not form the basis of any bargain between the parties, but are merely ClimateMaster's opinion or commendation of its products. The latest version of this document is available at climatemaster.com.



**Horizontal Wheeled Blower Data
Model 20 - Continued**

Airflow	20 - With Wheel			
CFM	ESP 0.5"	ESP 1"	ESP 1.5"	ESP 2"
7850	B	B	B	C
7900	B	B	B	C
7950	B	B	B	C
8000	B	B	B	C
8050	B	B	B	C
8100	B	B	C	C
8150	B	B	C	C
8200	B	B	C	C
8250	B	B	C	C
8300	B	B	C	C
8350	B	B	C	C
8400	B	B	C	C
8450	B	B	C	C
8500	B	C	C	C
8550	B	C	C	C
8600	B	C	C	C
8650	B	C	C	C
8700	B	C	C	C
8750	B	C	C	C
8800	B	C	C	C
8850	B	C	C	C
8900	C	C	C	C
THROUGH				
10031	C	C	C	C

Models 25 & 30 With Wheel - Please consult the factory.



Horizontal Non-Wheeled Blower Data Model 05

Airflow	05 - Without Wheel			
CFM	ESP 0.5"	ESP 1"	ESP 1.5"	ESP 2"
710	A	A	C	C
750	A	A	C	C
800	A	A	C	C
850	A	A	C	C
900	A	C	C	C
950	A	C	C	C
1000	A	C	C	C
1050	A	C	C	C
1100	A	C	C	C
1150	C	C	C	C
1165	C	C	C	C

Horizontal Non-Wheeled Blower Data Model 08

Airflow	08 - Without Wheel			
CFM	ESP 0.5"	ESP 1"	ESP 1.5"	ESP 2"
1000	A	A	A	A
1050	A	A	A	A
1100	A	A	A	A
1150	A	A	A	C
1200	A	A	A	C
1250	A	A	C	C
1300	A	A	C	C
1350	A	C	C	C
1400	A	C	C	C
1450	C	C	C	C
THROUGH				
1586	C	C	C	C



**Horizontal Non-Wheeled Blower Data
Model 10**

Airflow	10 - Without Wheel			
CFM	ESP 0.5"	ESP 1"	ESP 1.5"	ESP 2"
1250	A	A	B	B
1300	A	A	B	B
1350	A	A	B	B
1400	A	A	B	B
1450	A	B	B	B
1500	A	B	B	B
1550	A	B	B	C
1600	A	B	B	C
1650	B	B	B	C
1700	B	B	B	C
1750	B	B	C	C
1800	B	B	C	C
1850	B	B	C	C
1900	B	B	C	C
1950	B	C	C	C
2000	B	C	C	C
2050	B	C	C	C
2069	C	C	C	C

GO Series 60Hz - R22 Submittal Data Eng/I-P



Horizontal Non-Wheeled Blower Data Model 15

Airflow	15 - Without Wheel			
CFM	ESP 0.5"	ESP 1"	ESP 1.5"	ESP 2"
1850	A	A	B	B
1900	A	A	B	B
1950	A	A	B	B
2000	A	A	B	B
2050	A	A	B	B
2100	A	B	B	B
2150	A	B	B	B
2200	A	B	B	B
2250	A	B	B	C
2300	B	B	B	C
2350	B	B	B	C
2400	B	B	B	C
2450	B	B	B	C
2500	B	B	C	C
2550	B	B	C	C
2600	B	B	C	C
2650	B	C	C	C
2700	B	C	C	C
2750	B	C	C	C
2800	B	C	C	C
2850	C	C	C	C
THROUGH				
3005	C	C	C	C



**Horizontal Non-Wheeled Blower Data
Model 20**

Airflow	20 - Without Wheel			
CFM	ESP 0.5"	ESP 1"	ESP 1.5"	ESP 2"
2534	A	A	B	B
2550	A	A	B	B
2600	A	A	B	B
2650	A	A	B	B
2700	A	A	B	C
2750	A	A	B	C
2800	A	A	B	C
2850	A	A	B	C
2900	A	B	B	C
2950	A	B	B	C
3000	A	B	B	C
3050	A	B	B	C
3100	A	B	C	C
3150	A	B	C	C
3200	A	B	C	C
3250	B	B	C	C
3300	B	B	C	C
3350	B	B	C	C
3400	B	B	C	C
3450	B	C	C	C
3500	B	C	C	C
3550	B	C	C	C
3600	B	C	C	C
3650	B	C	C	C
3700	B	C	C	C
3750	B	C	C	C
3800	C	C	C	C
THROUGH				
4270	C	C	C	C

ClimateMaster works continually to improve its products. As a result, the design and specifications of each product at the time of order may be changed without notice and may not be as described herein. Please contact ClimateMaster's Customer Service Department at 1-405-745-6000 for specific information on the current design and specifications. Statements and other information contained herein are not express warranties and do not form the basis of any bargain between the parties, but are merely ClimateMaster's opinion or commendation of its products. The latest version of this document is available at climatemaster.com.

GO Series 60Hz - R22 Submittal Data Eng/I-P



Horizontal Wheeled Blower Data Model 25

Airflow	25 - Without Wheel			
CFM	ESP 0.5"	ESP 1"	ESP 1.5"	ESP 2"
3120	A	A	A	B
3150	A	A	A	B
3200	A	A	A	B
3250	A	A	A	B
3300	A	A	A	B
3350	A	A	A	B
3400	A	A	A	B
3450	A	A	A	B
3500	A	A	B	B
3550	A	A	B	B
3600	A	A	B	B
3650	A	A	B	B
3700	A	A	B	B
3750	A	A	B	B
3800	A	A	B	B
3850	A	B	B	B
3900	A	B	B	B
3950	A	B	B	B
4000	A	B	B	C
4050	A	B	B	C
4100	A	B	B	C
4150	A	B	B	C
4200	A	B	B	C
4250	B	B	B	C
4300	B	B	B	C
4350	B	B	C	C
4400	B	B	C	C
4450	B	B	C	C
4500	B	B	C	C
4550	B	B	C	C
4600	B	B	C	C
4650	B	C	C	C
4700	B	C	C	C
4750	B	C	C	C
4800	B	C	C	C
4850	B	C	C	C
4900	B	C	C	C
4950	C	C	C	C
THROUGH				
5194	C	C	C	C

ClimateMaster works continually to improve its products. As a result, the design and specifications of each product at the time of order may be changed without notice and may not be as described herein. Please contact ClimateMaster's Customer Service Department at 1-405-745-6000 for specific information on the current design and specifications. Statements and other information contained herein are not express warranties and do not form the basis of any bargain between the parties, but are merely ClimateMaster's opinion or commendation of its products. The latest version of this document is available at climatemaster.com.



**Horizontal Non-Wheeled Blower Data
Model 30**

Airflow	30 - Without Wheel			
CFM	ESP 0.5"	ESP 1"	ESP 1.5"	ESP 2"
3787	A	A	A	A
4200	A	A	A	A
4250	A	A	A	B
4300	A	A	A	B
4350	A	A	A	B
4400	A	A	A	B
4450	A	A	A	B
4500	A	A	A	B
4550	A	A	B	B
4600	A	A	B	B
4650	A	A	B	B
4700	A	A	B	B
4750	A	A	B	B
4800	A	A	B	B
4850	A	B	B	B
4900	A	B	B	B
4950	A	B	B	B
5000	A	B	B	B
5050	A	B	B	B
5100	A	B	B	B
5150	B	B	B	B
5200	B	B	B	C
5250	B	B	B	C
5300	B	B	B	C
5350	B	B	B	C
5400	B	B	B	C
5450	B	B	B	C
5500	B	B	C	C
5550	B	B	C	C
5600	B	B	C	C
5650	B	B	C	C
5700	B	B	C	C
5750	B	B	C	C
5800	B	C	C	C
5850	B	C	C	C
5900	B	C	C	C
5950	B	C	C	C
6000	B	C	C	C
6050	B	C	C	C
6100	C	C	C	C
THROUGH				
6400	C	C	C	C

ClimateMaster works continually to improve its products. As a result, the design and specifications of each product at the time of order may be changed without notice and may not be as described herein. Please contact ClimateMaster's Customer Service Department at 1-405-745-6000 for specific information on the current design and specifications. Statements and other information contained herein are not express warranties and do not form the basis of any bargain between the parties, but are merely ClimateMaster's opinion or commendation of its products. The latest version of this document is available at climatemaster.com.

GO Series 60Hz - R22 Submittal Data Eng/I-P



Horizontal Non-Wheeled Blower Data Model 36

Airflow	36 - Without Wheel			
CFM	ESP 0.5"	ESP 1"	ESP 1.5"	ESP 2"
4700	A	A	B	B
4750	A	A	B	B
4800	A	A	B	B
4850	A	A	B	B
4900	A	A	B	B
4950	A	A	B	B
5000	A	A	B	B
5050	A	A	B	B
5100	A	B	B	B
5150	A	B	B	B
5200	A	B	B	B
5250	A	B	B	B
5300	A	B	B	B
5350	A	B	B	B
5400	A	B	B	B
5450	B	B	B	B
5500	B	B	B	C
5550	B	B	B	C
5600	B	B	B	C
5650	B	B	B	C
5700	B	B	B	C
5750	B	B	B	C
5800	B	B	B	C
5850	B	B	C	C
5900	B	B	C	C
5950	B	B	C	C
6000	B	B	C	C
6050	B	B	C	C
6100	B	B	C	C
6150	B	C	C	C
6200	B	C	C	C
6250	B	C	C	C
6300	B	C	C	C
6350	B	C	C	C
6400	B	C	C	C
6450	B	C	C	C
6500	C	C	C	C
THROUGH				
7287	C	C	C	C

ClimateMaster works continually to improve its products. As a result, the design and specifications of each product at the time of order may be changed without notice and may not be as described herein. Please contact ClimateMaster's Customer Service Department at 1-405-745-6000 for specific information on the current design and specifications. Statements and other information contained herein are not express warranties and do not form the basis of any bargain between the parties, but are merely ClimateMaster's opinion or commendation of its products. The latest version of this document is available at climatemaster.com.



**Horizontal Non-Wheeled Blower Data
Model 40**

Airflow	40 - Without Wheel			
CFM	ESP 0.5"	ESP 1"	ESP 1.5"	ESP 2"
5450	A	A	B	B
5500	A	A	B	B
5550	A	A	B	B
5600	A	A	B	B
5650	A	B	B	B
5700	A	B	B	B
5750	A	B	B	C
5800	A	B	B	C
5850	A	B	B	C
5900	A	B	B	C
5950	A	B	B	C
6000	A	B	B	C
6050	A	B	B	C
6100	A	B	B	C
6150	A	B	B	C
6200	A	B	B	C
6250	A	B	B	C
6300	A	B	B	C
6350	A	B	B	C
6400	A	B	B	C
6450	A	B	B	C
6500	A	B	B	C
6550	A	B	C	C
6600	A	B	C	C
6650	B	B	C	C
6700	B	B	C	C
6750	B	B	C	C
6800	B	B	C	C
6850	B	B	C	C
6900	B	B	C	C
6950	B	B	C	C
7000	B	B	C	C
7050	B	B	C	C
7100	B	B	C	C
7150	B	B	C	C
7200	B	B	C	C
7250	B	B	C	C
7300	B	B	C	C

ClimateMaster works continually to improve its products. As a result, the design and specifications of each product at the time of order may be changed without notice and may not be as described herein. Please contact ClimateMaster's Customer Service Department at 1-405-745-6000 for specific information on the current design and specifications. Statements and other information contained herein are not express warranties and do not form the basis of any bargain between the parties, but are merely ClimateMaster's opinion or commendation of its products. The latest version of this document is available at climatemaster.com.

GO Series 60Hz - R22 Submittal Data Eng/I-P



Horizontal Non-Wheeled Blower Data Model 40 - Continued

Airflow	40 - Without Wheel			
CFM	ESP 0.5"	ESP 1"	ESP 1.5"	ESP 2"
7350	B	C	C	C
7400	B	C	C	C
7450	B	C	C	C
7500	B	C	C	C
7550	B	C	C	C
7600	B	C	C	C
7650	B	C	C	C
7700	B	C	C	C
7750	B	C	C	C
7800	B	C	C	C
7850	B	C	C	C
7900	B	C	C	C
7950	B	C	C	C
8000	B	C	C	C
8050	B	C	C	C
8100	B	C	C	C
8150	C	C	C	C
THROUGH				
8447	C	C	C	C



**Horizontal Non-Wheeled Blower Data
Model 46**

Airflow	46 - Without Wheel			
CFM	ESP 0.5"	ESP 1"	ESP 1.5"	ESP 2"
6120	A	B	B	C
6150	A	B	B	C
6200	A	B	B	C
6250	A	B	B	C
6300	A	B	B	C
6350	A	B	B	C
6400	A	B	B	C
6450	A	B	B	C
6500	A	B	B	C
6550	A	B	B	C
6600	A	B	B	C
6650	A	B	B	C
6700	A	B	B	C
6750	A	B	B	C
6800	A	B	B	C
6850	B	B	B	C
6900	B	B	C	C
6950	B	B	C	C
7000	B	B	C	C
7050	B	B	C	C
7100	B	B	C	C
7150	B	B	C	C
7200	B	B	C	C
7250	B	B	C	C
7300	B	B	C	C
7350	B	B	C	C
7400	B	B	C	C
7450	B	B	C	C
7500	B	B	C	C
7550	B	B	C	C
7600	B	B	C	C
7650	B	C	C	C
7700	B	C	C	C
7750	B	C	C	C
7800	B	C	C	C
7850	B	C	C	C
7900	B	C	C	C

ClimateMaster works continually to improve its products. As a result, the design and specifications of each product at the time of order may be changed without notice and may not be as described herein. Please contact ClimateMaster's Customer Service Department at 1-405-745-6000 for specific information on the current design and specifications. Statements and other information contained herein are not express warranties and do not form the basis of any bargain between the parties, but are merely ClimateMaster's opinion or commendation of its products. The latest version of this document is available at climatemaster.com.

GO Series 60Hz - R22 Submittal Data Eng/I-P



Horizontal Non-Wheeled Blower Data Model 46 - Continued

Airflow	46 - Without Wheel			
CFM	ESP 0.5"	ESP 1"	ESP 1.5"	ESP 2"
7950	B	C	C	C
8000	B	C	C	C
8050	B	C	C	C
8100	B	C	C	C
8150	B	C	C	C
8200	B	C	C	C
8250	B	C	C	C
8300	B	C	C	C
8350	B	C	C	C
8400	B	C	C	C
8450	C	C	C	C
THROUGH				
9418	C	C	C	C



**Horizontal Non-Wheeled Blower Data
Model 50**

Airflow	50 - Without Wheel			
CFM	ESP 0.5"	ESP 1"	ESP 1.5"	ESP 2"
6700	A	A	B	B
6750	A	A	B	B
6800	A	A	B	B
6850	A	A	B	B
6900	A	A	B	B
6950	A	A	B	B
7000	A	A	B	B
7050	A	A	B	B
7100	A	A	B	B
7150	A	A	B	B
7200	A	A	B	B
7250	A	A	B	B
7300	A	A	B	B
7350	A	A	B	B
7400	A	A	B	B
7450	A	A	B	B
7500	A	A	B	B
7550	A	A	B	C
7600	A	A	B	C
7650	A	B	B	C
7700	A	B	B	C
7750	A	B	B	C
7800	A	B	B	C
7850	A	B	B	C
7900	A	B	B	C
7950	A	B	B	C
8000	A	B	B	C
8050	A	B	B	C
8100	A	B	B	C
8150	A	B	B	C
8200	A	B	B	C
8250	A	B	B	C
8300	A	B	B	C
8350	A	B	B	C
8400	A	B	B	C
8450	A	B	B	C
8500	A	B	C	C
8550	A	B	C	C

ClimateMaster works continually to improve its products. As a result, the design and specifications of each product at the time of order may be changed without notice and may not be as described herein. Please contact ClimateMaster's Customer Service Department at 1-405-745-6000 for specific information on the current design and specifications. Statements and other information contained herein are not express warranties and do not form the basis of any bargain between the parties, but are merely ClimateMaster's opinion or commendation of its products. The latest version of this document is available at climatemaster.com.



**Horizontal Non-Wheeled Blower Data
Model 50 - Continued**

Airflow CFM	50 - Without Wheel			
	ESP 0.5"	ESP 1"	ESP 1.5"	ESP 2"
8600	B	B	C	C
8650	B	B	C	C
8700	B	B	C	C
8750	B	B	C	C
8800	B	B	C	C
8850	B	B	C	C
8900	B	B	C	C
8950	B	B	C	C
9000	B	B	C	C
9050	B	B	C	C
9100	B	B	C	C
9150	B	B	C	C
9200	B	B	C	C
9250	B	B	C	C
9300	B	B	C	C
9350	B	B	C	C
9400	B	C	C	C
9450	B	C	C	C
9500	B	C	C	C
9550	B	C	C	C
9600	B	C	C	C
9650	B	C	C	C
9700	B	C	C	C
9750	B	C	C	C
9800	B	C	C	C
9850	A	B	B	C
9900	A	B	B	C
9950	B	C	C	C
10000	B	C	C	C
10050	B	C	C	C
10100	B	C	C	C
10150	B	C	C	C
10200	B	C	C	C
10250	B	C	C	C
10300	C	C	C	C
10389	C	C	C	C

ClimateMaster works continually to improve its products. As a result, the design and specifications of each product at the time of order may be changed without notice and may not be as described herein. Please contact ClimateMaster's Customer Service Department at 1-405-745-6000 for specific information on the current design and specifications. Statements and other information contained herein are not express warranties and do not form the basis of any bargain between the parties, but are merely ClimateMaster's opinion or commendation of its products. The latest version of this document is available at climatemaster.com.



**Horizontal Non-Wheeled Blower Data
Model 56**

Airflow	56 - Without Wheel			
CFM	ESP 0.5"	ESP 1"	ESP 1.5"	ESP 2"
7700	A	A	A	B
7750	A	A	A	B
7800	A	A	A	B
7850	A	A	B	B
7900	A	A	B	B
7950	A	A	B	B
8000	A	A	B	B
8050	A	A	B	B
8100	A	A	B	B
8150	A	A	B	B
8200	A	A	B	B
8250	A	A	B	B
8300	A	A	B	B
8350	A	A	B	B
8400	A	A	B	B
8450	A	A	B	B
8500	A	A	B	B
8550	A	A	B	B
8600	A	A	B	B
8650	A	B	B	B
8700	A	B	B	B
8750	A	B	B	C
8800	A	B	B	C
8850	A	B	B	C
8900	A	B	B	C
8950	A	B	B	C
9000	A	B	B	C
9050	A	B	B	C
9100	A	B	B	C
9150	A	B	B	C
9200	A	B	B	C
9250	A	B	B	C
9300	A	B	B	C
9350	A	B	B	C
9400	B	B	B	C

ClimateMaster works continually to improve its products. As a result, the design and specifications of each product at the time of order may be changed without notice and may not be as described herein. Please contact ClimateMaster's Customer Service Department at 1-405-745-6000 for specific information on the current design and specifications. Statements and other information contained herein are not express warranties and do not form the basis of any bargain between the parties, but are merely ClimateMaster's opinion or commendation of its products. The latest version of this document is available at climatemaster.com.

GO Series 60Hz - R22 Submittal Data Eng/I-P



Horizontal Non-Wheeled Blower Data Model 56 - Continued

Airflow CFM	56 - Without Wheel			
	ESP 0.5"	ESP 1"	ESP 1.5"	ESP 2"
9450	B	B	C	C
9500	B	B	C	C
9550	B	B	C	C
9600	B	B	C	C
9650	B	B	C	C
9700	B	B	C	C
9750	B	B	C	C
9800	B	B	C	C
9850	B	B	C	C
9900	B	B	C	C
9950	B	B	C	C
10000	B	B	C	C
10050	B	B	C	C
10100	B	B	C	C
10150	B	C	C	C
10200	B	C	C	C
10300	B	C	C	C
10400	B	C	C	C
10500	B	C	C	C
10600	B	C	C	C
10700	B	C	C	C
10800	B	C	C	C
10900	B	C	C	C
11000	B	C	C	C
11100	B	C	C	C
11200	B	C	C	C
11300	B	C	C	C
11400	B	C	C	C
11500	B	C	C	C
11585	B	C	C	C



**Horizontal Non-Wheeled Blower Data
Model 60**

Airflow	60 - Without Wheel			
CFM	ESP 0.5"	ESP 1"	ESP 1.5"	ESP 2"
8500	A	A	B	B
8550	A	A	B	B
8600	A	A	B	B
8650	A	A	B	B
8700	A	A	B	B
8750	A	B	B	B
8800	A	B	B	B
8850	A	B	B	B
8900	A	B	B	B
8950	A	B	B	B
9000	A	B	B	B
9050	A	B	B	B
9100	A	B	B	B
9150	A	B	B	B
9200	A	B	B	C
9250	A	B	B	C
9300	A	B	B	C
9350	A	B	B	C
9400	A	B	B	C
9450	A	B	B	C
9500	B	B	B	C
9550	B	B	B	C
9600	B	B	B	C
9650	B	B	B	C
9700	B	B	B	C
9750	B	B	B	C
9800	B	B	B	C
9850	B	B	B	C

ClimateMaster works continually to improve its products. As a result, the design and specifications of each product at the time of order may be changed without notice and may not be as described herein. Please contact ClimateMaster's Customer Service Department at 1-405-745-6000 for specific information on the current design and specifications. Statements and other information contained herein are not express warranties and do not form the basis of any bargain between the parties, but are merely ClimateMaster's opinion or commendation of its products. The latest version of this document is available at climatemaster.com.



Horizontal Non-Wheeled Blower Data Model 60 - Continued

Airflow	60 - Without Wheel			
CFM	ESP 0.5"	ESP 1"	ESP 1.5"	ESP 2"
9900	B	B	C	C
9950	B	B	C	C
10000	B	B	C	C
10050	B	B	C	C
10100	B	B	C	C
10150	B	B	C	C
10200	B	B	C	C
10250	B	B	C	C
10300	B	B	C	C
10350	B	B	C	C
10400	B	B	C	C
10450	B	B	C	C
10500	B	B	C	C
10550	B	C	C	C
10600	B	C	C	C
10650	B	C	C	C
10700	B	C	C	C
10750	B	C	C	C
10800	B	C	C	C
10850	B	C	C	C
10900	B	C	C	C
10950	B	C	C	C
11000	B	C	C	C
11050	B	C	C	C
11100	B	C	C	C
11150	B	C	C	C
11200	C	C	C	C
14500	C	C	C	C

Horizontal Non-Wheeled Dimensional Data

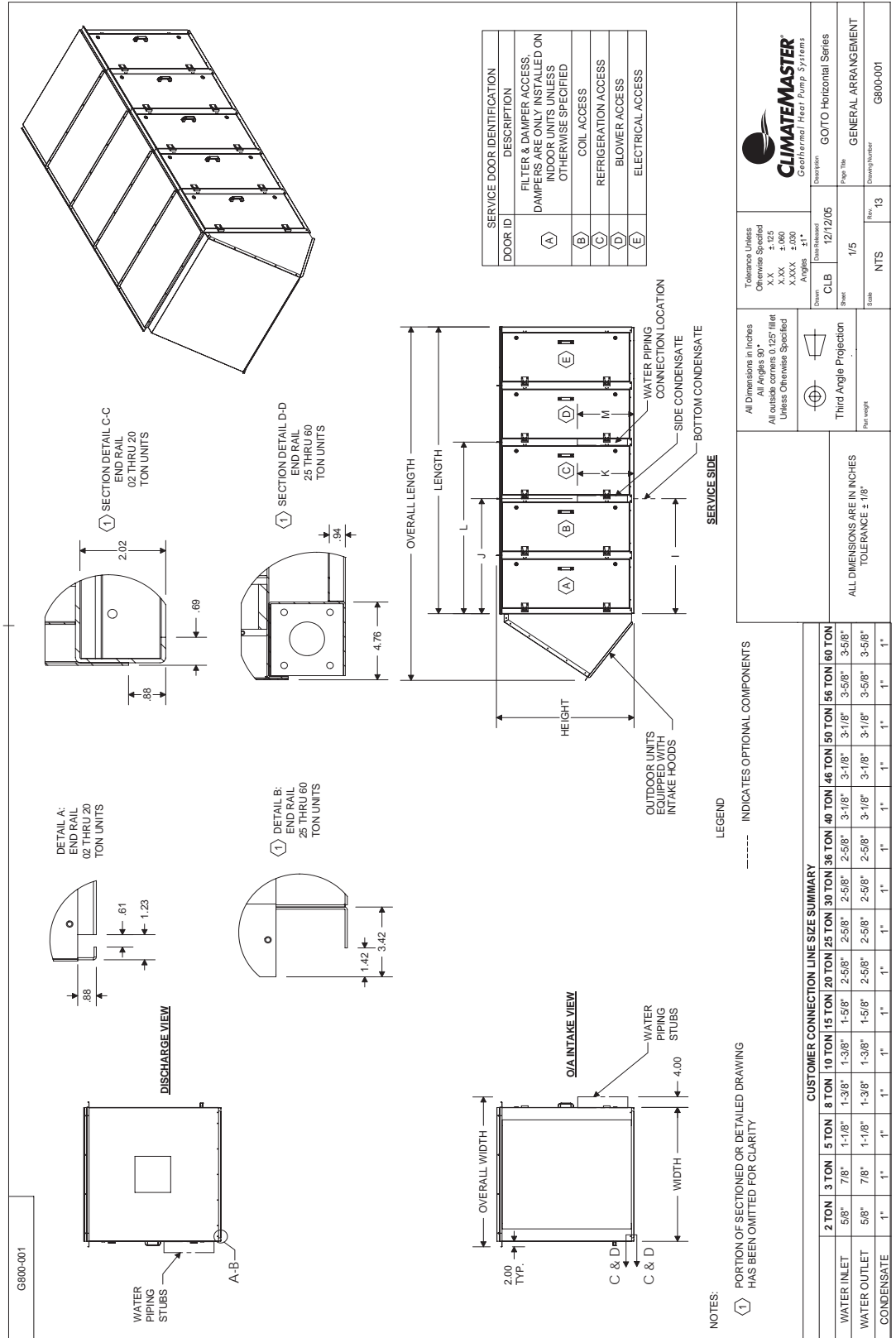

ClimateMaster works continually to improve its products. As a result, the design and specifications of each product at the time of order may be changed without notice and may not be as described herein. Please contact ClimateMaster's Customer Service Department at 1-405-745-6000 for specific information on the current design and specifications. Statements and other information contained herein are not express warranties and do not form the basis of any bargain between the parties, but are merely ClimateMaster's opinion or commendation of its products. The latest version of this document is available at climatemaster.com.

GO Series 60Hz - R22 Submittal Data Eng/I-P



Horizontal Non-Wheeled Dimensional Data

UNIT CABINET SIZE	UNIT SIZE (TONS)	OVERALL CABINET DIMENSIONS								SUPPLY DISCHARGE												
		LENGTH	WIDTH	HEIGHT	OVERALL WIDTH	OVERALL LENGTH	A	B	C	D	E	F	G	H	SIDE CONDENSATE				PIPE CONNECTIONS			
															I	J	K	L	M	TOTAL WEIGHT (LBS)		
24	02	80.18	37.12	43.89	43.12	102.30	13.57	10.38	15.06	7.00	02	2.13	38.79	6.23	23.88	30.19	26.94	19.63	26.99	20.00	1124	
	03	80.18	37.12	43.89	43.12	102.30	13.57	10.38	15.06	7.00	03	2.13	38.79	6.23	23.88	30.19	26.94	19.63	26.99	20.00	1148	
36	05	105.18	49.12	48.59	48.59	129.64	17.78	12.63	13.65	9.81	05	2.13	38.79	6.23	23.88	30.19	26.94	19.63	26.99	20.00	1293	
	08	105.18	49.12	48.59	48.59	129.64	17.78	12.63	13.65	9.81	08	2.13	44.49	6.23	35.88	42.34	42.19	17.63	62.94	20.00	1954	
	10	105.18	49.12	48.59	48.59	129.64	17.78	12.63	13.65	9.81	10	2.13	44.49	6.23	35.88	42.34	42.19	17.63	62.94	20.00	2093	
44	15	116.08	54.50	52.59	60.50	136.14	19.10	16.00	18.75	16.25	15	2.13	48.49	6.23	43.88	44.84	44.82	20.13	66.80	22.52	2855	
	20	114.18	61.12	63.07	67.12	144.70	24.57	16.00	21.18	18.75	20	4.50	56.49	5.62	49.88	45.79	45.81	20.13	68.31	22.52	3286	
50	30	117.18	72.50	75.39	78.50	153.09	9.04	19.00	25.25	22.00	30	4.50	56.49	5.62	49.88	45.79	45.81	20.13	68.31	22.52	3489	
	36	117.18	72.50	75.39	78.50	153.09	9.04	19.00	25.25	22.00	36	6.11	67.29	6.31	59.88	46.99	47.00	24.13	70.12	26.13	4545	
	40	117.18	72.50	75.39	78.50	153.09	9.04	19.00	25.25	22.00	40	6.11	67.29	6.31	59.88	46.99	47.00	24.13	70.12	26.13	4688	
72	50	125.18	87.50	83.57	93.50	165.19	9.04	19.00	32.75	22.00	50	6.11	75.49	7.81	71.88	50.19	50.24	24.13	70.12	26.13	4882	
	56	125.18	87.50	83.57	93.50	165.19	9.04	19.00	32.75	22.00	56	6.11	75.49	7.81	71.88	50.19	50.24	24.13	70.12	26.13	5610	
	60	125.18	87.50	83.57	93.50	165.19	9.04	19.00	32.75	22.00	60	6.11	75.49	7.81	71.88	50.19	50.24	24.13	70.12	26.13	5748	

DISCHARGE VIEW

INTAKE VIEW

NOTE: CURBS ARE AVAILABLE IN AN OPTIONAL PACKAGE

CLIMATE MASTER
Geothermal Heat Pump Systems

Tolerance Unless Otherwise Specified:
XXX ±.125
XXX ±.060
XXX ±.030
Angles ±1°

Drawn: CLB
Sheet: 12/12/05
Scale: 2/5

Description: GO/TO Horizontal Series
Page No: 13
Drawing Number: G800-001

All Dimensions in Inches
All Angles 90° unless otherwise specified
Unless Otherwise Specified

Third Angle Projection
Not weight

ALL DIMENSIONS ARE IN INCHES
TOLERANCE ± .1/8"



Horizontal Non-Wheeled Dimensional Data

UNIT SIZE		OVERALL CABINET DIMENSIONS													SUPPLY DISCHARGE						TOTAL WEIGHT (LBS)
CABINET SIZE	TONS	LENGTH	WIDTH	HEIGHT	OVERALL LENGTH			A2	B2			C2	D2								
					A1	A2	A3		B1	B2	B3										
24	02	80.18	37.12	43.89	43.12	102.30	1.19	14.00	14.12	14.12	14.12	14.12	12.76								
	03	80.18	37.12	43.89	43.12	102.30	1.19	14.00	14.12	14.12	14.12	14.12	12.76								
36	08	105.18	49.12	48.59	55.12	129.64	1.19	15.20	18.62	18.62	18.62	18.62	15.76								
	10	105.18	49.12	48.59	55.12	129.64	1.19	15.20	18.62	18.62	18.62	18.62	15.76								
44	15	105.18	49.12	48.59	55.12	129.64	1.19	19.00	17.25	18.51	18.51	17.25	18.51								
	20	111.68	54.50	52.59	60.50	138.14	1.19	20.30	18.31	21.76	21.76	18.31	21.76								
50	25	114.18	61.12	63.07	67.12	144.70	1.19	20.80	21.62	21.62	21.62	20.80	21.76								
	30	114.18	61.12	63.07	67.12	144.70	1.19	20.80	21.62	21.62	21.62	20.80	21.76								
60	40	117.18	72.50	75.39	78.50	153.09	1.19	21.20	27.31	27.31	27.31	21.20	21.76								
	46	117.18	72.50	75.39	78.50	153.09	1.19	21.20	24.81	24.81	24.81	21.20	26.76								
72	50	125.18	87.50	83.57	93.50	165.19	1.19	23.00	32.31	32.31	32.31	23.00	26.76								
	56	125.18	87.50	83.57	93.50	165.19	1.19	23.00	30.81	30.81	30.81	23.00	26.76								
80	60	125.18	87.50	83.57	93.50	165.19	1.19	23.00	30.81	30.81	30.81	23.00	26.76								

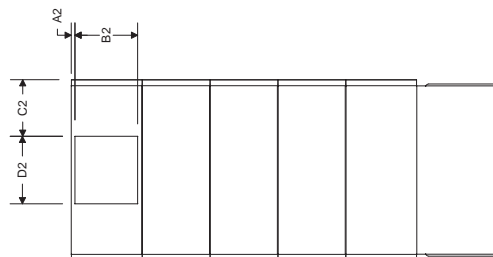

TOP VIEW

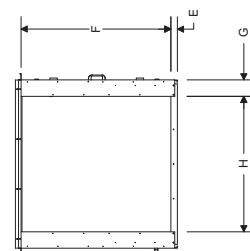

INTAKE VIEW

NOTE: CURBS ARE AVAILABLE IN AN OPTIONAL PACKAGE

All Dimensions in Inches Unless Otherwise Specified All outside to 0.125" Flange Unless Otherwise Specified				CLIMATEMASTER Geothermal Heat Pump Systems			
Tolerance Unless Otherwise Specified X.X ±0.125 X.XX ±0.060 X.XXX ±0.030				Description GO/TO Horizontal Series			
Sheet 3/5				Drawing Number G800-001			
Title TOP DISCHARGE				Revision 13			
Scale 1/8"				Date 12/12/05			
Drawing Number NTS				Revision 13			
ALL DIMENSIONS ARE IN INCHES TOLERANCE ± .1/8"							



Horizontal Non-Wheeled Dimensional Data

UNIT CABINET SIZE (TONS)	OVERALL CABINET DIMENSIONS						SUPPLY DISCHARGE					
	LENGTH	WIDTH	HEIGHT	OVERALL WIDTH	OVERALL LENGTH	A1	B1	CT	CI	DI	DF	
02	80.18	37.12	48.89	43.12	102.20	5.62	10.38	15.06	7.00			
03	80.18	37.12	48.89	43.12	102.20	5.62	10.38	15.06	7.00			
05	80.18	37.12	48.89	43.12	102.20	5.62	10.38	15.06	7.00			
08	105.18	48.12	48.89	55.12	128.64	5.62	12.63	17.34	13.25			
10	105.18	48.12	48.89	55.12	128.64	5.62	12.63	17.34	13.25			
15	105.18	48.12	48.89	55.12	128.64	5.62	12.63	17.34	13.25			
20	114.18	61.12	60.07	67.12	148.72	7.62	16.00	21.19	18.75			
25	114.18	61.12	60.07	67.12	148.72	7.62	16.00	21.19	18.75			
30	114.18	61.12	60.07	67.12	148.72	7.62	16.00	21.19	18.75			
36	117.18	72.60	70.53	78.60	153.09	8.12	18.00	23.25	22.00			
46	117.18	72.60	70.53	78.60	153.09	8.12	18.00	23.25	22.00			
56	126.18	87.50	83.57	93.50	166.18	8.12	24.88	31.31	24.88			
60	126.18	87.50	83.57	93.50	166.18	8.12	24.88	31.31	24.88			

UNIT CABINET SIZE (TONS)	O/A INTAKE						SIDE CONDENSATE						PIPE CONNECTIONS			TOTAL WEIGHT (LBS)
	E	F	G	H	I	J	K	L	M							
02	2.13	39.79	6.23	23.98	30.19	26.94	19.63	26.99	20.00	11.24						
03	2.13	39.79	6.23	23.98	30.19	26.94	19.63	26.99	20.00	11.24						
05	2.13	39.79	6.23	23.98	30.19	26.94	19.63	26.99	20.00	11.24						
08	2.13	44.48	6.23	35.98	42.34	42.19	17.83	42.94	20.00	19.54						
10	2.13	44.48	6.23	35.98	42.34	42.19	17.83	42.94	20.00	19.54						
15	2.13	44.48	6.23	35.98	42.34	42.19	17.83	42.94	20.00	19.54						
20	2.13	48.48	5.31	43.98	46.84	44.82	20.13	46.80	22.52	23.65						
25	2.13	48.48	5.31	43.98	46.84	44.82	20.13	46.80	22.52	23.65						
30	4.50	56.48	5.62	49.98	49.79	46.81	20.13	46.81	22.52	23.65						
36	6.11	67.29	6.31	59.88	48.99	47.00	24.13	70.12	26.13	4.64						
46	6.11	67.29	6.31	59.88	48.99	47.00	24.13	70.12	26.13	4.64						
56	6.11	75.48	7.81	71.88	50.19	50.24	15.50	74.89	26.13	5.975						
60	6.11	75.48	7.81	71.88	50.19	50.24	15.50	74.89	26.13	5.975						

NOTES:

1) PORTION OF SECTIONED DRAWING HAS BEEN OMITTED FOR CLARITY

CURBS ARE AVAILABLE IN AN OPTIONAL PACKAGE

ALL DIMENSIONS ARE IN INCHES
TOLERANCE ± .18"

CLIMATEMASTER
Geothermal Heat Pump Systems

Tolerance Unless Otherwise Specified:
XXX ±.005
XXX ±.000
XXX ±.030
Angles ±1°

Drawn: CLB
Date Released: 12/12/05
Sheet: 4/5
Title: NTS
Revision: 13

Description: GO10 Horizontal Series
Page Title: BOTTOM DISCHARGE
Drawing Number: G8000-001

ClimateMaster works continually to improve its products. As a result, the design and specifications of each product at the time of order may be changed without notice and may not be as described herein. Please contact ClimateMaster's Customer Service Department at 1-405-745-6000 for specific information on the current design and specifications. Statements and other information contained herein are not express warranties and do not form the basis of any bargain between the parties, but are merely ClimateMaster's opinion or commendation of its products. The latest version of this document is available at climatemaster.com.

Horizontal Non-Wheeled Dimensional Data

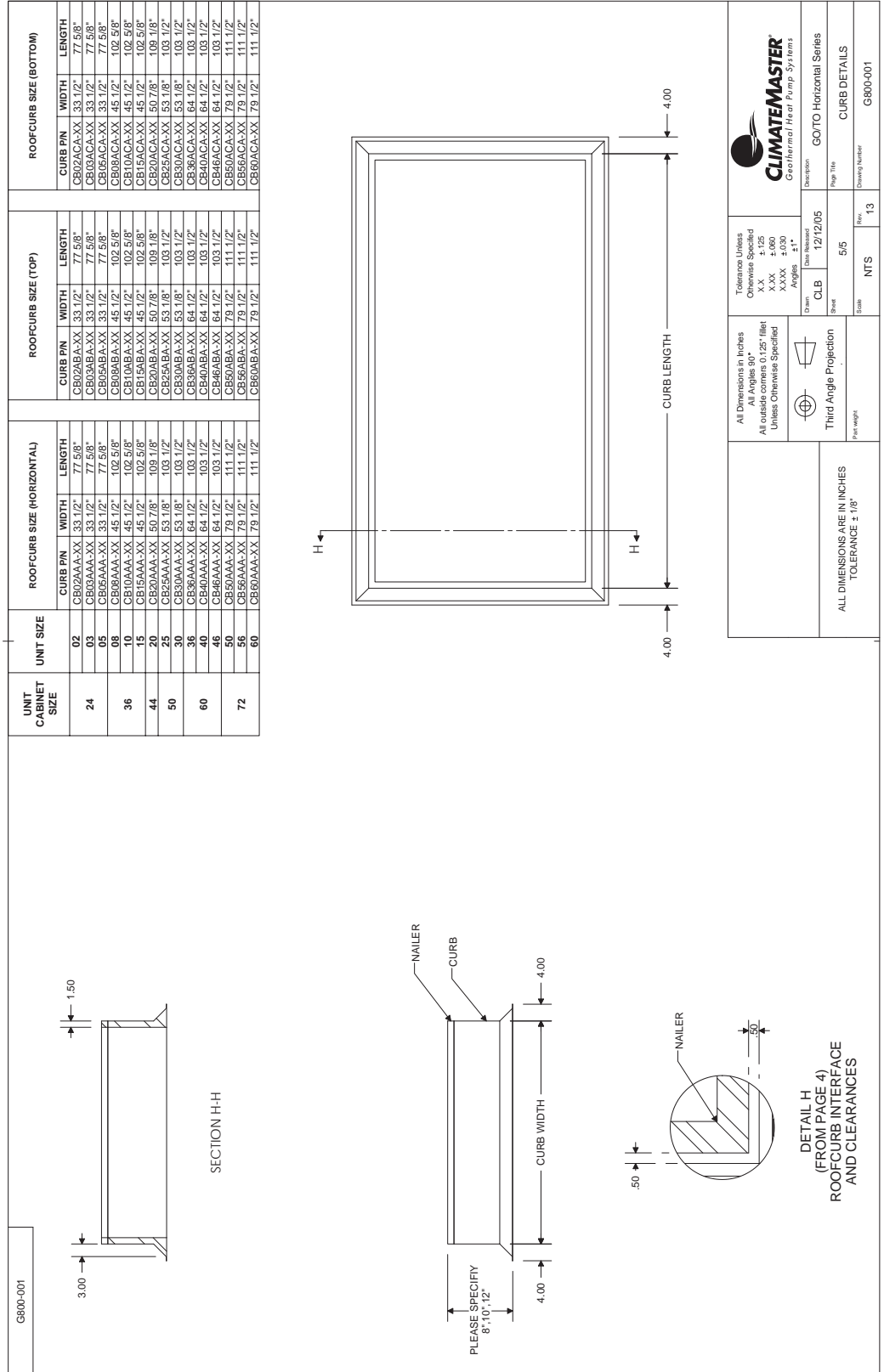

ClimateMaster works continually to improve its products. As a result, the design and specifications of each product at the time of order may be changed without notice and may not be as described herein. Please contact ClimateMaster's Customer Service Department at 1-405-745-6000 for specific information on the current design and specifications. Statements and other information contained herein are not express warranties and do not form the basis of any bargain between the parties, but are merely ClimateMaster's opinion or commendation of its products. The latest version of this document is available at climatemaster.com.

GO Series 60Hz - R22 Submittal Data Eng/I-P



Horizontal Wheeled Dimensional Data

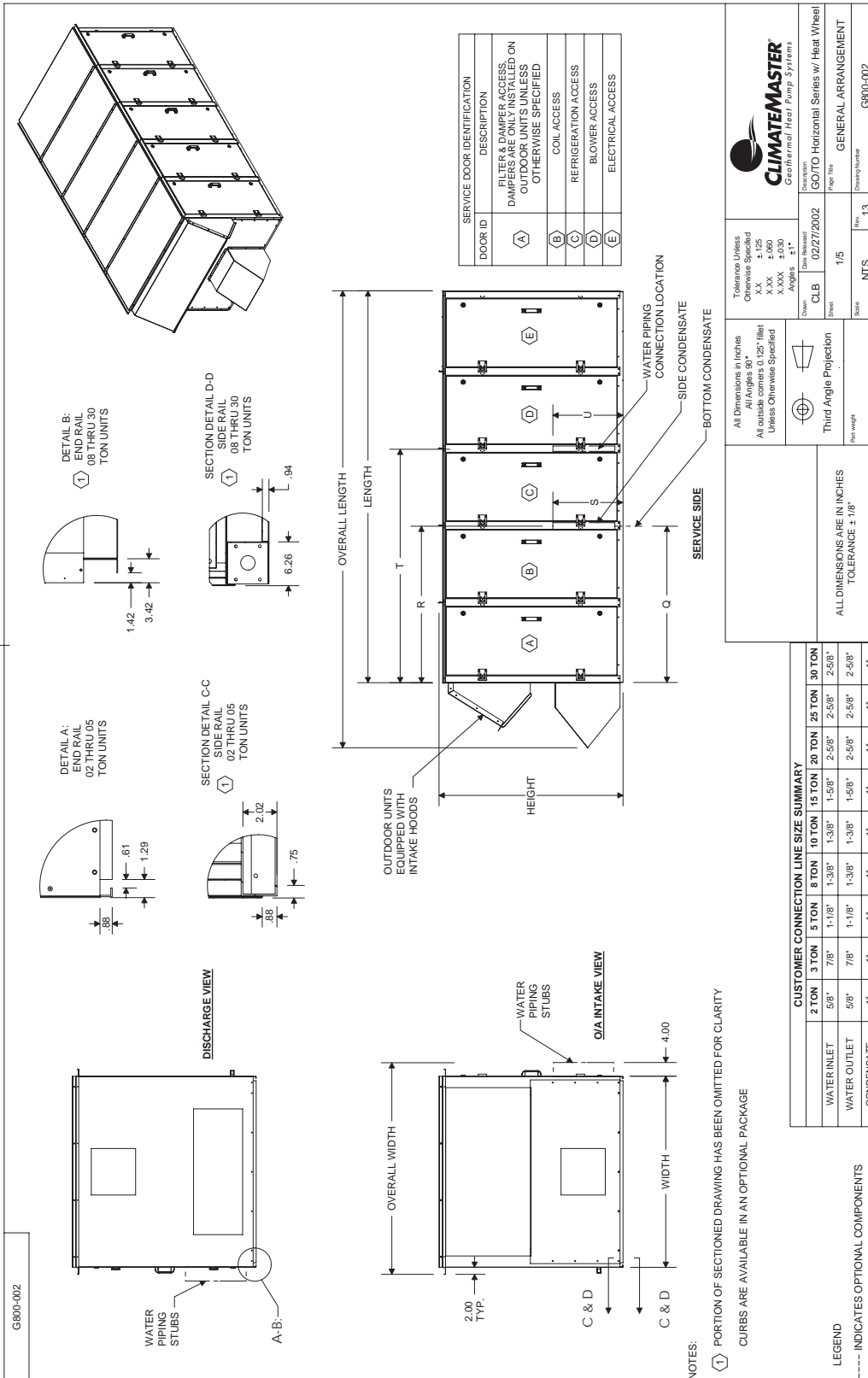

ClimateMaster works continually to improve its products. As a result, the design and specifications of each product at the time of order may be changed without notice and may not be as described herein. Please contact ClimateMaster's Customer Service Department at 1-405-745-6000 for specific information on the current design and specifications. Statements and other information contained herein are not express warranties and do not form the basis of any bargain between the parties, but are merely ClimateMaster's opinion or commendation of its products. The latest version of this document is available at climatemaster.com.

Horizontal Wheeled Dimensional Data

UNIT CABINET SIZE	UNIT SIZE (TONS)	OVERALL CABINET DIMENSIONS						SUPPLY DISCHARGE						RETURN INTAKE						TOTAL UNIT WEIGHT (LBS)
		LENGTH	WIDTH	HEIGHT	OVERALL WIDTH	OVERALL LENGTH	A	B	C	D	E	F	G	H						
36-H	02	105.24	49.12	48.59	55.12	123.79	30.39	12.63	20.37	6.38	3.88	10.00	9.32	30.49						
44-H	05	111.74	54.50	52.59	60.50	130.29	34.39	12.63	20.63	13.25	3.88	14.00	9.32	35.87						
50-H	08	114.24	61.12	63.07	67.12	137.79	41.97	16.00	22.56	16.00	6.36	20.50	9.32	42.49						
60-H	10	117.24	72.50	75.39	79.50	140.79	54.52	16.00	28.13	16.25	7.86	30.00	9.32	53.87						
72-H	15	125.24	87.50	83.57	93.50	153.72	60.56	17.75	31.94	23.63	7.86	35.00	9.32	68.87						
78-H	20	135.24	90.50	92.57	96.50	164.21	57.52	19.50	32.31	25.88	7.86	35.00	9.32	71.87						
	25	135.24	90.50	92.57	96.50	164.21	57.52	25.24	32.63	25.24	7.86	32.00	9.32	71.87						
	30	135.24	90.50	92.57	96.50	164.21	57.52	25.24	32.63	25.24	7.86	32.00	9.32	71.87						

UNIT CABINET SIZE	UNIT SIZE (TONS)	EXHAUST DISCHARGE						BOTTOM CONDENSATE						R/E CONDENSATE CONNECTIONS						O/A INTAKE						TOTAL UNIT WEIGHT (LBS)
		M	N	O	P	Q	R	S	T	U	V	W	X	Y	Z	AA	AB	AC	AD	AE	AF	AG	AH			
36-H	02	5.06	12.63	20.37	8.38	52.34	62.94	22.00	62.94	20.00	28.51	18.11	6.62	35.88	2064											
44-H	05	5.06	12.63	20.63	13.25	54.84	66.79	27.00	66.79	22.52	26.51	23.82	5.31	43.88	2468											
50-H	08	7.54	16.00	22.56	16.00	55.79	68.31	33.00	68.31	22.52	36.99	23.82	5.62	49.88	2888											
60-H	10	9.04	16.00	28.25	16.25	56.99	70.12	38.00	70.12	26.13	43.29	29.82	6.31	59.88	3635											
72-H	15	9.04	17.75	31.94	23.63	60.19	74.89	46.00	74.89	26.13	45.59	35.82	7.81	71.88	5180											
78-H	20	9.04	19.50	32.31	23.88	69.84	80.94	41.00	80.94	26.13	45.59	41.82	6.31	77.88	5886											
	25	7.20	25.25	32.63	25.25	69.84	80.94	41.00	80.94	26.13	45.59	41.82	6.31	77.88	6277											
	30	7.20	25.25	32.63	25.25	69.84	80.94	41.00	80.94	26.13	45.59	41.82	6.31	77.88	6468											

DISCHARGE VIEW

INTAKE VIEW

NOTE: CURBS ARE AVAILABLE IN AN OPTIONAL PACKAGE

ALL DIMENSIONS ARE IN INCHES
TOLERANCE ± .10"

Down: 7/2/2001
EWS
Tolerance Unless Otherwise Specified
X.X ±.125
X.XX ±.063
X.XXX ±.031
Angles ±1°

CLIMATEMASTER
Geothermal Heat Pump Systems

Description: GOTO Horizontal Series w/ Heat Wheel
Page Title: HORIZONTAL DISCHARGE
Rev: 13
Drawing Number: G800-002

GO Series 60Hz - R22 Submittal Data Eng/I-P



Horizontal Wheeled Dimensional Data

UNIT CABINET SIZE	UNIT SIZE (TONS)	OVERALL CABINET DIMENSIONS						SPLIT WITH WHEEL, TOP DISCHARGE						SUPPLY DISCHARGE						RETURN INTAKE						TOTAL WEIGHT (LBS)
		LENGTH		WIDTH		HEIGHT		OVERALL LENGTH		OVERALL WIDTH		OVERALL HEIGHT		A2	B2	C2	D2	E	F	G	H					
		M	N	O	P	Q	R	S	T	U	V	W	X	Y	Z	AA	AB	AC	AD	AE	AF	AG	AH			
36-H	02	105.24	49.12	48.59	55.12	123.79	1.19	15.20	20.12	12.88	3.88	10.00	9.32	30.49												
44-H	03	105.24	49.12	48.59	55.12	123.79	1.19	15.20	18.62	15.88	3.88	10.00	9.32	30.49												
50-H	05	111.74	54.50	52.59	60.50	130.29	1.19	20.60	23.25	19.63	6.36	20.50	9.32	35.87												
60-H	08	114.24	61.12	63.07	67.12	137.79	1.19	21.20	27.31	21.88	7.86	30.00	9.32	42.49												
72-H	10	117.24	72.50	75.39	78.50	140.79	1.19	23.00	30.31	30.88	7.86	36.00	9.32	48.87												
78-H	15	125.24	87.50	83.57	96.50	153.72	1.19	24.50	31.81	30.88	7.86	32.00	9.32	51.87												
	20	135.24	90.50	92.57	96.50	164.21	1.19	24.50	31.81	30.88	7.86	32.00	9.32	51.87												
	25	135.24	90.50	92.57	96.50	164.21	1.19	24.50	31.81	30.88	7.86	32.00	9.32	51.87												
	30	135.24	90.50	92.57	96.50	164.21	1.19	24.50	31.81	30.88	7.86	32.00	9.32	51.87												
UNIT CABINET SIZE	UNIT SIZE (TONS)	EXHAUST DISCHARGE						BOTTOM CONDENSATE						PIPE CONNECTIONS						O/A INTAKE						TOTAL WEIGHT (LBS)
		M	N	O	P	Q	R	S	T	U	V	W	X	Y	Z	AA	AB	AC	AD	AE	AF	AG	AH			
		02	5.06	12.63	20.37	8.38	52.34	62.94	22.00	62.94	20.00	28.51	18.11	6.62	35.88	2016										
03	5.06	12.63	20.37	13.25	52.34	62.94	22.00	62.94	20.00	28.51	18.11	6.62	35.88	2064												
08	7.54	16.00	22.56	13.25	54.84	66.79	27.00	66.79	22.52	26.51	23.62	5.31	43.88	2488												
10	9.04	16.00	22.56	16.25	56.99	70.12	38.00	70.12	26.13	43.29	29.82	6.31	59.88	2835												
15	9.04	17.75	31.94	23.63	60.19	74.89	46.00	74.89	26.13	45.49	35.82	7.81	71.88	5180												
20	9.04	19.50	32.31	25.88	69.84	80.94	41.00	80.94	26.13	45.49	41.82	6.31	77.88	5986												
25	7.20	25.25	32.63	25.25	69.84	80.94	41.00	80.94	26.13	45.49	41.82	6.31	77.88	6277												
30	7.20	25.25	32.63	25.25	69.84	80.94	41.00	80.94	26.13	45.49	41.82	6.31	77.88	6488												

DISCHARGE VIEW

TOP VIEW

INTAKE VIEW

NOTE: CURBS ARE AVAILABLE IN AN OPTIONAL PACKAGE

CLIMATEMASTER
Geothermal Heat Pump Systems

Tolerance Unless Otherwise Specified
X.X ±.125
X.XX ±.060
X.XXX ±.030
Angles ±1°

Description: GOTO Horizontal Series w/ Heat Wheel
Page Title: TOP DISCHARGE
Drawing Number: G800-002

All Dimensions in Inches
All Angles 90°
All outside corners 0.125" fillet
Unless Otherwise Specified

Third Angle Projection

Scale: NTS

Sheet: 3/5

Per weight

Revision: 13

ClimateMaster works continually to improve its products. As a result, the design and specifications of each product at the time of order may be changed without notice and may not be as described herein. Please contact ClimateMaster's Customer Service Department at 1-405-745-6000 for specific information on the current design and specifications. Statements and other information contained herein are not express warranties and do not form the basis of any bargain between the parties, but are merely ClimateMaster's opinion or commendation of its products. The latest version of this document is available at climatemaster.com.

Horizontal Wheeled Dimensional Data

UNIT CABINET SIZE	UNIT SIZE (TONS)	OVERALL CABINET DIMENSIONS					SPLIT, WITH WHEEL, BOTTOM DISCHARGE															TOTAL WEIGHT (LBS)																
		LENGTH	WIDTH	HEIGHT	OVERALL WIDTH	OVERALL LENGTH	A1	B1	C1	D1	E1	F1	G1	H1	I1	J1	K1	L1	M1	N1	O1	P1	Q1	R1	S1	T1	U1	V1	W1	X1	Y1	Z1						
36-H	03	105.24	49.12	48.50	55.12	123.76	0.01	14.33	16.14	10.26	15.84	13.00	5.93	30.69																								
44-H	05	111.74	54.50	52.59	60.50	130.29	0.01	14.33	16.40	15.13	15.84	13.00	5.93	30.69																								
50-H	08	123.54	61.12	63.07	67.12	147.09	1.28	15.94	16.65	16.88	20.22	18.69	3.74	42.69																								
60-H	10	126.54	72.50	75.39	83.50	150.09	0.88	17.60	26.78	23.00	21.48	22.78	3.74	42.69																								
72-H	15	156.74	87.50	92.57	96.50	185.71	0.80	19.50	26.90	25.76	25.30	32.05	3.74	42.69																								
78-H	20	165.12	90.50	92.57	96.50	191.09	0.80	21.91	31.40	25.76	27.71	33.64	3.74	42.69																								
78-H	30	162.12	90.50	92.57	96.50	191.09	0.80	21.91	31.40	25.76	27.71	33.64	3.74	42.69																								
UNIT SIZE (TONS)		EXHAUST DISCHARGE					CONDENSATE CONNECTIONS															O/A INTAKE		TOTAL WEIGHT (LBS)														
02	5.06	12.63	20.37	8.38	52.34	62.94	22.00	62.94	20.00	28.51	18.11	6.62	35.88	2064																								
03	5.06	12.63	20.37	13.25	54.84	66.79	27.00	66.79	22.52	26.51	23.82	5.31	43.88	2468																								
05	5.06	12.63	20.63	16.00	22.56	56.79	16.00	56.79	16.00	16.00	16.00	16.00	16.00	16.00																								
08	7.54	16.00	22.56	16.00	56.79	60.19	16.00	60.19	16.00	16.00	16.00	16.00	16.00	16.00																								
10	9.04	16.00	28.25	16.00	60.19	60.19	16.00	60.19	16.00	16.00	16.00	16.00	16.00	16.00																								
15	9.04	17.75	31.84	16.00	60.19	60.19	16.00	60.19	16.00	16.00	16.00	16.00	16.00	16.00																								
20	9.04	19.50	32.31	25.88	60.19	60.19	16.00	60.19	16.00	16.00	16.00	16.00	16.00	16.00																								
25	7.20	25.25	32.63	25.25	69.84	69.84	16.00	69.84	16.00	16.00	16.00	16.00	16.00	16.00																								
30	7.20	25.25	32.63	25.25	69.84	69.84	16.00	69.84	16.00	16.00	16.00	16.00	16.00	16.00																								

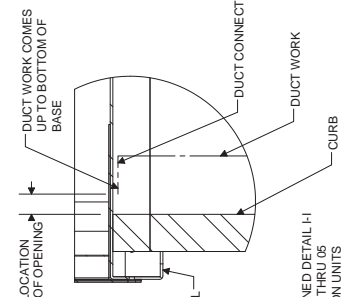
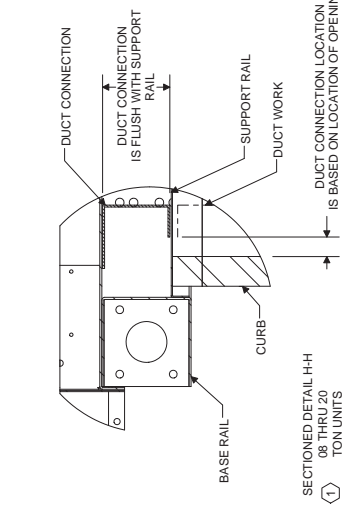
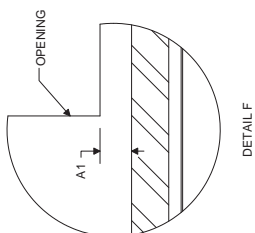

NOTES:
 (1) PORTION OF SECTIONED VIEW HAS BEEN OMITTED FOR CLARITY
 CURBS ARE AVAILABLE IN AN OPTIONAL PACKAGE

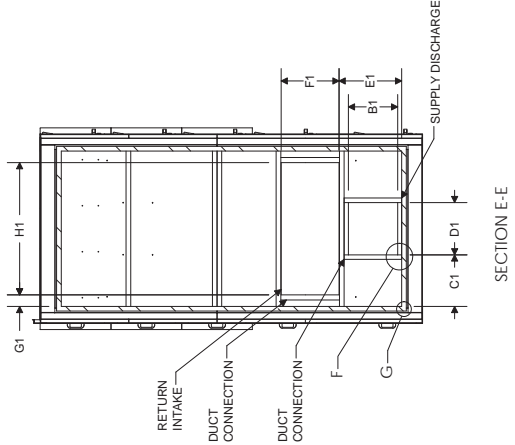

CLIMATEMASTER
Geothermal Heating & Cooling Systems

Drawn: 7/22/2001
 Checked: X.XX
 In Charge: X.XX
 Project: 7/22/2001
 Revision: 4/5
 Scale: NTS
 Page No: 13
 Drawing Number: G800-002

Section: GO TO Horizontal Series w/ Heat Wheel
 Bottom Discharge

ALL DIMENSIONS IN INCHES
 TOLERANCE ± 1/8"

GO Series 60Hz - R22 Submittal Data Eng/I-P



Horizontal Wheeled Dimensional Data

UNIT CABINET SIZE	UNIT SIZE	ROOFCURB SIZE (HORIZONTAL)			ROOFCURB SIZE (BOTTOM)			ROOFCURB SIZE (TOP)		
		CURB PIN	WIDTH	LENGTH	CURB PIN	WIDTH	LENGTH	CURB PIN	WIDTH	LENGTH
36-H	02	CB02DA-XX	45 1/2"	102 3/4"	CB02DA-XX	45 1/2"	102 3/4"	CB02DA-XX	45 1/2"	102 3/4"
44-H	03	CB03DA-XX	45 1/2"	102 3/4"	CB03DA-XX	45 1/2"	102 3/4"	CB03DA-XX	44 1/2"	102 3/4"
50-H	05	CB05DA-XX	50 7/8"	109 1/4"	CB05DA-XX	50 7/8"	109 1/4"	CB05DA-XX	50 7/8"	109 1/4"
60-H	08	CB08DA-XX	53 7/8"	112 7/8"	CB08DA-XX	53 7/8"	112 7/8"	CB08DA-XX	53 1/8"	103 1/2"
72-H	10	CB10DA-XX	64 1/2"	112 7/8"	CB10DA-XX	64 1/2"	112 7/8"	CB10DA-XX	64 1/2"	103 1/2"
	15	CB15DA-XX	69 1/2"	121 1/2"	CB15DA-XX	69 1/2"	121 1/2"	CB15DA-XX	69 1/2"	112 1/2"
	24	CB24DA-XX	82 1/2"	143 1/8"	CB24DA-XX	82 1/2"	143 1/8"	CB24DA-XX	82 1/2"	121 1/2"
78-H	24	CB24DA-XX	82 1/2"	143 1/8"	CB24DA-XX	82 1/2"	143 1/8"	CB24DA-XX	82 1/2"	121 1/2"
	30	CB30DA-XX	82 1/2"	143 1/8"	CB30DA-XX	82 1/2"	143 1/8"	CB30DA-XX	82 1/2"	121 1/2"

SECTION J-J

PLEASE SPECIFY 8" 10" OR 12" CURB

DETAIL G (FROM PAGE 4) CURB INTERFACE AND CLEARANCES

ALL DIMENSIONS ARE IN INCHES TOLERANCE ± .18"

All Dimensions in Inches unless otherwise specified. All outside corners 90° 125° fillet unless otherwise specified.	Tolerances Unless Otherwise Specified X.X ±.125 X.XX ±.060 X.XXX ±.030	Date: 7/2/2001	Revision: 5/5	Scale: NTS	Box: 13
		Drawn:	Checked:	Title: CURB DETAILS	Drawing Number: G800-002

ClimateMaster works continually to improve its products. As a result, the design and specifications of each product at the time of order may be changed without notice and may not be as described herein. Please contact ClimateMaster's Customer Service Department at 1-405-745-6000 for specific information on the current design and specifications. Statements and other information contained herein are not express warranties and do not form the basis of any bargain between the parties, but are merely ClimateMaster's opinion or commendation of its products. The latest version of this document is available at climatemaster.com.



GO/HD/RD Physical Data Table

Model	4	5	8	10	15	20
Fan motor available H.P.	CF	0.5/1.5	0.5/1.5	0.5/1.0/3.0	1.0/1.5/5.0	1.5/2.0/5.0
Blower wheel size	CF	10-07	11-10	11-10	12-12	15-12
Compressor type/qty	Scroll, 1 ea.		Scroll (tandem), 2ea.			
Factory charge lb/unit						
R-22 Genesis units	12 [192]	14 [224]	18 [288]	24 [384]	36 [576]	56 [896]
Water Connection Size " O.D.	7/8"	1 1/8"	1 3/8"	1 3/8"	1 5/8"	2 5/8"
Water Flow Rate GPM	11	19	26	34	49	69
Water Pressure Drop PSI/Ft	4.1/9.45	4.0/9.23	5.4/12.46	6.6/15.22	9.4/21.68	6.2/14.30
Condensate Connection Size	1"	1"	1"	1"	1"	1"
Miscellaneous Data						
Filter qty/size	(2) 18 X 24 X 4	(2) 18 X 24 X 4	(4) 20 X 24 X 4	(4) 20 X 24 X 4	(4) 20 X 24 X 4	(6) 18 X 24 X 4
Filter Type	Merv 11, Pleated					
Operating Weight	1148	1293	1954	2093	2491	2855
Shipping Weight	1189	1350	2030	2190	2643	3042

Model	25	30	36	40	46	50
Fan motor available H.P.	2.0/3.0/7.5	3.0/5.0/10.0	3.0/5.0/10.0	30./5.0/10.0	3.0/5.0/15.0	5.0/7.5/15
Blower wheel size	15-15	15-15	15-15	918	920	920
Compressor type/qty	Scroll (tandem), 2ea.		Scroll 4 ea. (2 ea tandem sets) (Dual refrigerant circuits)			
Factory charge lb/unit						
R-22 Genesis units	67 [1072]	79 [1264]	100 [1600]	118 [1888]	136 [2176]	184 [2944]
Water Connection Size " O.D.	2 5/8"	2 5/8"	2 5/8"	3 1/8"	3 1/8"	3 1/8"
Water Flow Rate GPM	84	102	118	137	153	168
Water Pressure Drop PSI/Ft	6.2/14.30	7.1/16.38	7.1/16.38	7.8/18.00	8.2/18.91	10.4/24.00
Condensate Connection Size	1"	1"	1"	1"	1"	1"
Miscellaneous Data						
Filter qty/size	(4) 28 X 30 X 4	(4) 28 X 30 X 4	(9) 20 X 24 X 4	(9) 20 X 24 X 4	(9) 20 X 24 X 4	(9) 25 X 29 X 4
Filter Type	Merv 11, Pleated					
Operating Weight	3256	3499	4545	4698	4852	5375
Shipping Weight	3478	3753	4846	5033	5247	5768

Model	56	60	80	99
Fan motor available H.P.	5.0/7.5/15	5.0/7.5/20	CF	CF
Blower wheel size	920	922	CF	CF
Compressor type/qty	Scroll 4 ea. (2 ea tandem sets) (Dual refrigerant circuits)			
Factory charge lb/unit				
R-22 Genesis units	204 [3264]	226 [3616]	246 [3936]	380 [6080]
Water Connection Size " O.D.	3 5/8"	3 5/8"	Consult Factory	
Water Flow Rate GPM	186	203	Consult Factory	
Water Pressure Drop PSI/Ft	12.6/29.06	13.3/30.68	Consult Factory	
Condensate Connection Size	1"	1"	Consult Factory	
Miscellaneous Data				
Filter qty/size	(9) 25 X 29 X 4	(9) 25 X 29 X 4	(9) 25 X 29 X 4	(9) 25 X 29 X 4
Filter Type	Merv 11, Pleated			
Operating Weight	5610	5748	Consult Factory	
Shipping Weight	6072	6210	Consult Factory	

ClimateMaster works continually to improve its products. As a result, the design and specifications of each product at the time of order may be changed without notice and may not be as described herein. Please contact ClimateMaster's Customer Service Department at 1-405-745-6000 for specific information on the current design and specifications. Statements and other information contained herein are not express warranties and do not form the basis of any bargain between the parties, but are merely ClimateMaster's opinion or commendation of its products. The latest version of this document is available at climatemaster.com.

GO Series 60Hz - R22 Submittal Data Eng/I-P



GO/HW/RW Physical Data Table

Model	3	5	8	10
Fan motor available H.P.	0.5/1.0/2.0	1.0/1.5/5.0	3.0/7.5	2.0/3.0/7.5
Blower wheel size	11-08	11-08	15-09	15-12
Compressor type/qty	Scroll, 1 ea.		Scroll, 2ea. (1 tandem set)	
Factory charge lb/unit				
R-22 Genesis units	10 [160]	16 [256]	21 [336]	29 [464]
Water Connection Size " O.D.	7/8"	1 1/8"	1 3/8"	1 3/8"
Water Flow Rate GPM	11	19	26	34
Water Pressure Drop PSI/Ft Hd	4.1/9.45	4.0/9.23	5.4/12.45	6.6/15.22
Condensate Connection Size	1"	1"	1"	1"
Miscellaneous Data				
Filter qty/size, Supply/ Outdoor Air	(2) 20 X 24 X 4	(3) 18 X 24 X 4	(2) 28 X 30 X 4	(3) 24 X 24 X 4
Filter qty/size, Return/Exhaust Air	(2) 20 X 24 X 4	(3) 18 X 24 X 4	(2) 28 X 30 X 4	(3) 24 X 24 X 4
Filter Type	Merv 11, Pleated			
Operating Weight Lbs. (less curb)	2064	2468	2888	3635
Shipping Weight	2105	2525	2963	3733

Model	15	20	25	30
Fan motor available H.P.	3.0/5.0/10.0	5.0/7.5/15.0	CF	CF
Blower wheel size	BIDI-16	BIDI-18	CF	CF
Compressor type/qty	Scroll, 2ea. (1 tandem set)			
Factory charge lb/unit				
R-22 Genesis units	44[704]	64[1024]	88 [1408]	107 [1712]
Water Connection Size " O.D.	1 5/8"	2 5/8"	2 5/8"	2 5/8"
Water Flow Rate GPM	49	69	84	102
Water Pressure Drop PSI/Ft	9.4/21.68	6.2/14.30	6.2/14.03	7.1/16.38
Condensate Connection Size	1"	1"	1"	1"
Miscellaneous Data				
Filter qty/size, Supply/ Outdoor Air	(3) 25 X 29 X 4	(3) 28 X 30 X 4	(3) 28 X 30 X 4	(3) 28 X 30 X 4
Filter qty/size, Return/Exhaust Air	(3) 25 X 29 X 4	(3) 28 X 30 X 4	(3) 28 X 30 X 4	(3) 28 X 30 X 4
Filter Type	Merv 11, Pleated			
Operating Weight Lbs. (less curb)	5180	5886	6277	6468
Shipping Weight	5332	6073	6498	6722

NOTE 1: A strainer is required on the ENTERING WATER connection to the DOAS unit.

The strainer must be provided and installed by others.

The strainer must be 60 mesh (250 Micron) or finer.

Failure to install a properly sized strainer can lead to premature fouling and possible failure of a brazed plate heat exchanger.

DOAS units installed and operated without a properly sized strainer will not qualify for warranty coverage.

NOTE 2: A dedicated 115 VAC, 15 Amp circuit (by others) is required on all DOAS units for operation of the factory installed evaporator heat tape(s). Failure to connect heat tape(s) to a proper power supply may lead to freezing of the water in the heat exchanger. Failure of, and/or damage caused by the failure of a heat exchanger due to freezing will be exempt from warranty coverage if the heat tapes are not properly connected and working at the time of the failure.



**Blower Motor HP
and Blower Wheel Size Table**

HW/RW Blower Motor HP Table

	Drive Selection			
	A	B	C	
Model	Motor Horse Power			Blower Wheel Size
03	0.5	1.0	2.0	110-8
05	1.0	1.5	5.0	110-8
08	N/A	3.0	7.5	15-9
10	2.0	3.0	7.5	15-12
15	3.0	5.0	10.0	BIDI-16
20	5.0	7.5	15	BIDI-18
25	Consult Factory			
30				

HD/RD Blower Motor HP Table

	Drive Selection			
	A	B	C	
Model	Motor Horse Power			Blower Wheel Size
05	0.5	N/A	1.5	110-7
08	0.5	N/A	1.5	110-10
10	0.5	1.0	3.0	110-10
15	1.0	1.5	5.0	120-12
20	1.5	2.0	5.0	15-12
25	2.0	3.0	7.5	15-15
30	3.0	5.0	10.0	15-15
36	3.0	5.0	10.0	15-15
40	3.0	5.0	10.0	918
46	3.0	5.0	15.0	920
50	5.0	7.5	15.0	920
56	5.0	7.5	15.0	920
60	5.0	7.5	20.0	922
80	Consult Factory			
99				

ClimateMaster works continually to improve its products. As a result, the design and specifications of each product at the time of order may be changed without notice and may not be as described herein. Please contact ClimateMaster's Customer Service Department at 1-405-745-6000 for specific information on the current design and specifications. Statements and other information contained herein are not express warranties and do not form the basis of any bargain between the parties, but are merely ClimateMaster's opinion or commendation of its products. The latest version of this document is available at climatemaster.com.



Sequence of Operation

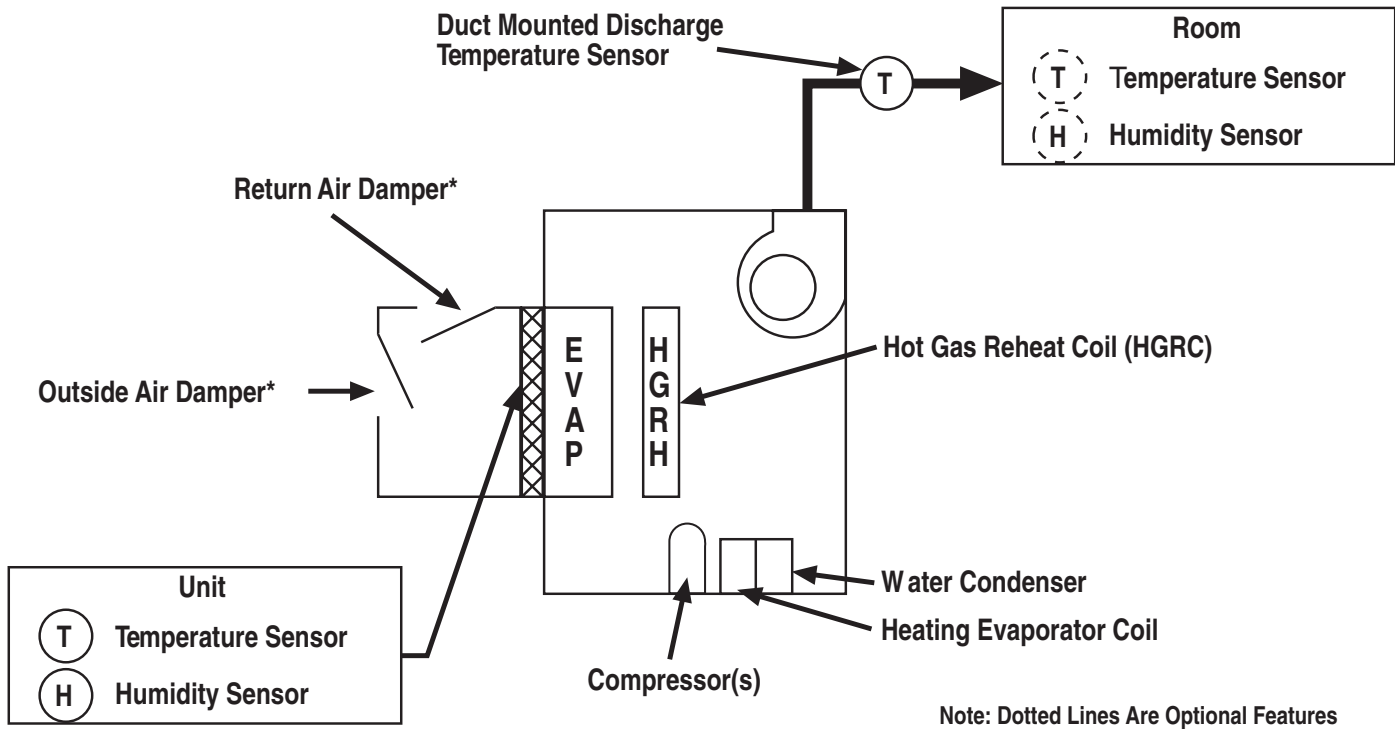

Sensor Control Definitions and Location

Unit Temperature and Humidity Sensors

A temperature and humidity sensor shall be located before the evaporator coil. The sensors feed back to the unit microprocessor the dry bulb temperature and relative humidity entering the evaporator (mixed air conditions for damper box applications).

Leaving Temperature Sensor

The supply air sensor shall be located in the supply air ductwork (by others). The sensor feeds back to the unit microprocessor the discharge air dry bulb temperature.

Space Temperature Sensor (Optional)

The room temperature sensor shall be located in the conditioned room. The sensor feeds back to the unit microprocessor the room air dry bulb temperature. A space temperature sensor is required for room reset of leaving air temperature and/or unoccupied space temperature control options

Space Humidity Sensor (Optional)

The humidity sensor shall be located in the conditioned room. The sensor feeds back to the unit microprocessor the room relative humidity (RH). A space RH sensor will be required with the unoccupied space humidity control option.

* = Damper(s) box available for vertical units only.

Damper/Mixing box for horizontal units supplied and installed by others.

Damper/Mixing box not compatible with rooftop units or horizontal units with an ERV wheel.

Control Features, Selections, and Sequence of Operation

Control Features:

Standard Control features include:

- **Emergency System Shutdown (ESS)**
Emergency System Shutdown shall be controlled by a customer supplied smoke detector or other dry contact. Upon opening of the remote contact the ESS mode will be initiated and all fan(s), motor(s), and compressor(s) will be immediately deactivated and will remain off as long as the ESS signal remains. Upon closure of the remote contact the ESS mode will be terminated and the DOAS unit will return the unit to the normal mode of operation.
- **Exhaust Fan Interlock**
Exhaust Fan Interlock shall be provided by a dry contact on the DOAS unit to enable/disable a remote exhaust fan by others. The Exhaust Fan Interlock will cycle with the DOAS unit supply air blower demand to provide exhaust air during the 100% OA mode. Supply air blower operation will be controlled by the unit DDC controller and will be determined by the Control Type selected and the mode of operation.
- **Controller Interface/Display Module**
The DOAS Controller Interface/Display Module is a user-operated interface to provide information on unit status, Entering Air Temperature, Entering Air RH, and unit LAT. The interface module is furnished as a standard accessory and is required to access user adjustable set points, differentials, time schedule(s), etc. when not connected to an active DDC network. The Display Module requires field installation and can be mounted on or near the DOAS unit or in a remote location up to 330 ft [100 m] from the DOAS unit. Installation will require a twisted pair wire with shield.
- The DOAS unit DDC controller is compatible with most Building Management Systems (BMS) and is available in a variety of communication protocols.

◆ REVISION B CONTROLS

A Carel Controls DDC controller is factory provided as standard. The Carel controller is a native Carel protocol. Additional protocol options are available by ordering an accessory Interface Card with the appropriate protocol selection. Selections should be noted when ordering a DOAS unit and include;

- BACnet MS/TP
- BACnet Ethernet
- Modbus
- LON works

Damper/Mixing Box

- Vertical units may be ordered with a factory provided damper box with actuator. The damper box will be shipped assembled but field assembly to the DOAS unit will be required.

OA and RA dampers will operate together from a single actuator and will be controlled by the DOAS unit DDC controller. Damper positions will be preset based on the customer specified OA and RA CFM. Damper settings are approximate and are not guaranteed. Air test and balance of the OA and RA should be conducted after installation is complete to insure proper air balance. Customer supplied damper/mixing boxes are acceptable on vertical and horizontal indoor mounted DOAS units not equipped with an Energy Recovery Wheel (model HW). Damper/Mixing boxes are not compatible with Roof mounted DOAS units (model RD/RW). All field assembly, adjustment, and air balance is to be provided by others.



Control Features, Selections, and Sequence of Operation

Control Features (cont):

Required/Optional Control Accessories

- **Outside Air Temperature/Humidity Sensor**

An Outside Air (OA) sensor is required for proper DOAS unit operation. A combination Temp/RH sensor will be factory installed on the entering airside of the unit. On DOAS units with an Energy Recovery Wheel the sensor will be mounted upstream of the OA entering the wheel.

- **Leaving Air Temperature Sensor**

A Leaving Air Temperature sensor will be required with the LAT control option to maintain the LAT at the design set point. The LAT sensor will ship as an accessory item and requires field installation in the supply air duct to the space. The sensor must be installed in a convenient location that will allow accurate sensing of the SA Temperature, more than 5 linear feet from the fan outlet, and must NOT be within "line of sight" of any Auxiliary heater (if used).

The LAT sensor will be included as standard on DOAS units equipped with the Carel Controller. DOAS units with the optional JCI Controller will require selection of the LAT sensor as an accessory item and must be ordered separately from the unit.

- **Space Temperature Sensor**

A space Temperature sensor will be required when the Room Reset of LAT option is selected and/or when temperature control is desired during the Unoccupied mode. The sensor will be used to communicate the space temperature to the DOAS unit controller. A wall mounted space temperature sensor is offered for each controller type and should be selected and ordered when the DOAS unit is ordered with the RRLAT option or when a damper box will be used and control of the space temperature is desired during the Unoccupied mode.

The space temperature sensor will ship as an accessory and requires field installation into the space for which it is intended to control. A duct mounted temperature sensor will only be acceptable provided the supply blower(s) operates continuously. Multiple space sensors may be used for averaging of up to four (4) separate zones.

- **Space Humidity Sensor**

A Space Humidity sensor will be required when space RH control is desired during the Unoccupied mode. The RH sensor will be used to determine the space relative humidity and start the DOAS unit in the Cooling/Dehumidification mode. A wall mounted humidity sensor is offered for each control type and should be selected and ordered when the DOAS unit is ordered. The Space Humidity sensor will ship as an accessory and requires field installation into the space for which it is intended to control. A duct mounted humidity sensor will be acceptable provided the supply blower(s) operates continuously.

Control Type Selections:

Control selections are based on desired operation of the DOAS unit during various parts of the day. DOAS units can operate in the Occupied mode continuously for 24 hour conditioning to meet Outdoor Air (OA) or Make-up Air (MA) requirements or can operate on a time schedule to provide Occupied and Unoccupied operation.

The DOAS unit can shut down during an Unoccupied mode or continue to condition the space Temperature and/or Relative Humidity by re-circulation of the space return air through a field installed damper box.

One of these Control Types must be selected when the unit is ordered. Field installed sensors, controls, and wiring may be required.

Control Features, Selections, and Sequence of Operation

Control Type Selections (cont):

Control selection options include;

- ◆ Leaving Air Temperature (LAT)
- ◆ Room Reset of LAT (RRLAT)
- ◆ Unoccupied Temperature and/or Humidity Control.

Leaving Air Temperature (LAT) Control Option

Occupied Mode:

The standard Occupied Control Type is Leaving Air Temperature (LAT) control. Upon initiation of the Occupied mode the Outside Air Damper will be commanded open. After confirmation the OA Damper is in the open position (end switch) the DOAS unit fan(s) will be enabled and will operate continuously until the next scheduled Unoccupied mode.

Compressor(s) will be staged ON and OFF dependent on the Outside Air (OA) and LAT conditions. The LAT sensor will require field mounting in the Supply Air duct at a convenient location that will sense an accurate supply Air temperature.

Factory supplied Variable Frequency Drives (VFD) for the blower motor(s) is not available. Discharge Air CFM from the DOAS unit will be constant and at the design CFM specified in the unit selection program. Field balance of the Supply Air CFM by others will be required.

The DOAS unit controller uses a PID feed back loop to modulate a hot gas reheat valve in small incremental steps to provide a constant LAT (+/- .2 °F). Discharge Air will be at or below the design Leaving Air Dew point (LADP) as specified in the unit selection program.

- ◆ Sequence of Operation

Cooling/Dehumidification Mode:

- ◆ The Cooling/Dehumidification mode demand will initiate compressor staging based on OA conditions to cool and dehumidify the supply air at or below the design LADP and will reheat the air as needed to maintain the design LAT as specified in the unit selection program.
- ◆ Compressor(s) will activate when;
 - The OA Dew point is above the system set point of 60 F [16 °C] or,
 - When the OA temperature is above 70 F db [21 °C], even if the air OA Dew point is below the design Dew point set point.

The hot refrigerant gas reheat coil on the airside will provide reheat as required to maintain the design LAT. Refrigerant not fully condensed in the reheat coil will be condensed in the water-cooled heat exchanger.

Leaving Air Temperature (LAT) Control Option (cont)

Air Heating Mode:

- When Cooling or Dehumidification is not required AND the LAT is below the design set point the DOAS unit will operate in the Air Heating mode. In the Air Heating mode the DOAS unit will divert low-pressure refrigerant from the airside coil to a waterside heat exchanger. No cooling or dehumidification of the OA will be provided in the Air Heating Mode. The hot refrigerant gas reheat coil on the airside will provide heating as required. Refrigerant not fully condensed in the reheat coil will be condensed in the water-cooled heat exchanger. Only the required

ClimateMaster works continually to improve its products. As a result, the design and specifications of each product at the time of order may be changed without notice and may not be as described herein. Please contact ClimateMaster's Customer Service Department at 1-405-745-6000 for specific information on the current design and specifications. Statements and other information contained herein are not express warranties and do not form the basis of any bargain between the parties, but are merely ClimateMaster's opinion or commendation of its products. The latest version of this document is available at climatemaster.com.



Control Features, Selections, and Sequence of Operation

amount of heat to maintain the LAT will be rejected into the air stream. Heat not required to maintain the LAT will be rejected back into building water loop for use elsewhere. In some of the coldest locations an Auxiliary Heater may be required to insure the design LAT can be maintained. The DOAS selection software program will display a notice if Aux. Heat is required as well as the recommended capacity for the heater in kW and BTU. Auxiliary heater(s) should be installed in the Supply Air stream after the DOAS unit SA blower and can be enabled/disabled by the DOAS unit through an Aux Heat Relay dry contact closure? Auxiliary heater(s) must be field provided and installed by others. Aux heater types may include Electric, Gas fired, Hot Water, Steam, etc.

Unoccupied Mode:

When the DOAS unit Unoccupied mode is initiated the compressor(s) and blower fan(s) will be commanded off. The OA Damper will be commanded to the closed position and the unit will remain shut down until the next scheduled Occupied mode.

Control Type Selections (cont):

Room Reset of LAT (RRLAT)

The RRLAT control option will be active only when the DOAS unit is in the Occupied mode.

The RRLAT control option requires a space mounted temperature sensor. The sensor is available as an accessory item and must be selected when the unit is ordered. Multiple space sensors may be used (up to four (4) maximum). Multiple sensors will be averaged.

The DOAS unit controller utilizes a PID feed back loop to reset the LAT based on the Space temperature. As the Space Temperature increases from set point the LAT will be incrementally lowered to help offset the space heat gain. As the Space Temperature decreases from set point the LAT will be incrementally raised to help offset the space heat loss. The DOAS unit controller has the capability to reset the LAT to the full Cooling (no reheat) and full Heating (no Dehumidification) modes.

Selection of the RRLAT control option may have a positive effect on the space conditioning equipment. By helping to offset some of the heat gain/loss the space conditioning equipment may operate less, or not be required on mild days, and may allow the space conditioning equipment to be downsized. Heat gain/loss calculations to determine the effect on the space conditioning equipment with the DOAS RRLAT control option will be required. The RRLAT control option will work best in a large zone with a dedicated DOAS unit. A DOAS unit applied to several small zones with mis-matched loads may lead to overcooling or over heating of some zones. Multiple space sensors should be used to average the zone temperatures.

◆ Sequence of Operation:

- When the Space Temperature is equal to the space set point the DOAS unit will maintain the design LAT.
- When the Space Temperature is greater than the space set point the DOAS controller will incrementally lower the LAT set point to help offset the heat gain and maintain the space temperature.
- When the Space Temperature is less than the space set point the DOAS controller will incrementally raise the LAT set point to help offset the heat loss and maintain the space temperature.

Control Features, Selections, and Sequence of Operation

Control Type Selections (cont):

Unoccupied Temperature and/or Humidity Control

Unoccupied Space Temperature Control will require a space mounted Temperature sensor. Multiple space sensors may be used (up to four (4) maximum). Multiple space temperature sensors will be averaged.

Unoccupied Space Humidity Control will require a space mounted Humidity sensor. Only one space humidity sensor per DOAS unit may be used.

Both sensors may be used for Unoccupied Space Temperature and Humidity Control.

Sensors are available as accessories and must be ordered with the DOAS unit.

NOTE: Unoccupied Temp and/or RH Control requires a field installed damper or mixing box. Control for operation of one damper actuator by the DOAS unit is provided. A factory assembled Damper Box is available as an option for Vertical units only. Damper box requires field assembly to the DOAS unit.

◆ Sequence of Operation:

Unoccupied Temperature Control:

- When the Space Temperature is above the Unoccupied Space Set point of 85 °F [29 °C] (field adjustable) the fan(s) and compressor(s) will be commanded on and the DOAS unit will operate in the full Cooling mode until the Space Temperature falls below the space set point minus the Unoccupied Cooling Differential.
- When the Space Temperature is below the Unoccupied set point of 65°F [18 °C] (field adjustable) the DOAS unit will operate in the full Air Heating mode until the space temperature rises above the set point plus the heating Unoccupied Differential.

Unoccupied Humidity Control:

- When the Space relative Humidity (RH) is above the set point of 60% RH the fan(s) and compressor(s) will be commanded on and the DOAS unit will operate in the Air Reheat mode until the Space RH drops below the space set point minus the Unoccupied Humidity Differential.

Unoccupied Temperature and Humidity Control:

- When both Space Temperature and Humidity sensors are used the DOAS unit will operate as described above for both modes. The Cooling mode will have priority over the Dehumidification mode. If both the Space Temperature and Space RH are above set point the full Cooling mode will be initiated until the cooling demand is satisfied. When the Cooling demand is satisfied the DOAS unit will then operate in the Air Reheat mode until the Dehumidification demand is satisfied or the Cooling demand is again initiated.



Genesis HD & RD

Engineering Specifications Rev.: 02/06/09 Page 1

MODELS "GOHD / GORD" SIZE 03-99 100% OUTDOOR AIR
WATER SOURCE HEAT PUMP SPECIFICATIONS
Rev. October 30, 2006

General:

Furnish and install ClimateMaster "Genesis" horizontal (HD) / rooftop (RD) high efficient 100% OA Water Source Heat Pumps, as indicated on the plans. Equipment shall be completely assembled, piped and internally wired. The unit shall include the following minimum components: Compressor(s), dehumidification/cooling coil, hot gas reheat coil, receiver, blower motors, controls and water cooled condenser and heat pump evaporator. Units shall have Variable Hot Gas Reheat and leaving air temperature control to $\pm 0.2^{\circ}\text{F}$ ($\pm 0.1^{\circ}\text{C}$) in cooling/dehumidification and heating modes. Capacities and characteristics shall be as listed in the schedule and the specifications that follow.

Horizontal / Rooftop 100% OA Water Source Heat Pumps:

Units shall be supplied completely factory built for an entering water temperature range from 35° to 105°F (1.7° to 40.6°C) as standard. Equivalent units from other manufacturers can be proposed provided approval to bid is given 10 days prior to bid closing. All equipment listed in this section must be tested in accordance with American Refrigeration Institute / International Standards Organization (ARI / ISO) and certified in accordance with UL 1995 Second Edition. The units shall have an ETL-US label. All units shall be fully quality tested by factory run testing under design operating conditions and water flow rates as described herein. The following quality control system checks shall be performed: triple leak check, pressure tests, evacuate and accurately charge system, perform detailed heating, dehumidification and cooling mode tests, and hot gas reheat mode testing. **Units tested without water flow are not acceptable.**

Basic Construction:

HD model units shall be constructed for indoor installation and usage. RD model units shall be constructed for outdoor installation and usage and shall include rain hood, low leak outdoor air isolation damper with 24V motorized actuator, and additional weather-stripping for improved weather resistance. The cabinet shall be 1" (25.4mm) double wall construction, 16-gauge (1.5mm) galvaneal outer panels and 22gauge (0.7mm) galvanized metal inner liner. RD model units shall be tested in accordance with UL rain test standards. A 12-gauge (2.5MM) galvanized base rail assembly shall be incorporated with the unit base pan for the base of the unit.

All exterior and other painted surfaces shall be constructed of galvaneal steel with a powder coated painted finished. Painting shall be by a powder coat technique to assure positive adherence with a high-impact finish. All sides of panels shall be painted. The panels shall be rated to meet a minimum of 1,000-hour salt spray test. Unit color shall be light gray. This corrosion protection system shall meet the stringent 1000-hour salt spray test per ASTM B117.

The unit roof shall be constructed as described above with a standing seam construction. All roof edges shall overlap sides of unit and have lip extending away from unit sides so that rainwater drippage shall not fall on top of access doors.

Unit shall be single side access. Access to filters, indoor blower, electrical controls, compressor compartment, and damper section shall be provided by double wall access doors with hinges, and compression latches with non-corrosive handles. All external fasteners shall be stainless steel bolts. **Self-taping or drive screws are unacceptable.**

Bottom base pan of entire unit shall have no penetrations by bolts or screws.

All double wall cabinet panels shall house a 1 inch (25.4mm) thick, solid foam insulation with a minimum "R" factor of 5.0. **Unit insulation must meet these stringent requirements or unit(s) will not be accepted.**

Entire unit base shall be insulated on the underneath side to provide condensation protection, and noise attenuation.

RD Outdoor cabinets shall include a rain hood and low leak isolation dampers with 24v motorized actuator

The unit shall be furnished with 4" (100mm) filter racks and one set 4" (100mm) MERV 8 pleated filters.

Fan and Motor Assembly:

The assembly shall include a fan, housing and solid steel fan shaft encased in ball bearings. Unit shall have a belt drive fan assembly, fan pulley and adjustable motor sheave with v-belt drive. Fan shall be forward curved, low speed centrifugal that has been statically and dynamically balanced, and tested in accordance with current A.M.C.A. standards bulletin 210. Fan bearings shall be permanently lubricated type and be self-aligning. The motor shall be single- or three-phase (as specified), high efficiency, ClimateMaster works continually to improve its products. As a result, the design and specifications of each product at the time of order may be changed without notice and may not be as described herein. Please contact ClimateMaster's Customer Service Department at 1-405-745-6000 for specific information on the current design and specifications. Statements and other information contained herein are not express warranties and do not form the basis of any bargain between the parties, but are merely ClimateMaster's opinion or commendation of its products. The latest version of this document is available at climatemaster.com.

Genesis HD & RD

Engineering Specifications Rev.: 02/06/09 Page 2

ball bearing, open type with internal thermal overload protection. The motor shall be mounted on an adjustable base for proper belt tension. The fan and motor assembly must be capable of overcoming the external static pressures as shown on the schedule. Airflow / Static pressure rating of the unit shall be based on a wet coil and a clean filter in place.

Refrigerant Circuit:

Units shall have a sealed refrigerant circuit including a high efficiency scroll compressor(s) designed for heat pump operation, a thermostatic expansion valve for refrigerant metering, an enhanced corrugated aluminum lanced fin and rifled copper tube refrigerant to air heat exchanger, plate refrigerant to water heat exchanger, plate water to refrigerant evaporator, hot gas reheat / heat pump heating coil, liquid receiver, modulating HGRH controls and safety controls including a high pressure switch, low pressure switch (loss of charge), water coil low temperature sensor, and air coil low temperature sensor. The unit shall be provided with a refrigerant receiver. The receiver will assist the unit in operating at the highest efficiency over the entire operating range of load conditions.

Access fittings shall be factory installed on high and low pressure refrigerant lines to facilitate field service. Activation of any safety device shall prevent compressor operation via a microprocessor lockout circuit. The lockout circuit shall be reset at the contractor supplied disconnect switch. **100% OA WSHP units that utilize a reversing operation shall not be acceptable.**

Unit refrigeration circuit shall allow entering OA as low as 15°F (-9°C) without the use of preheat. **Units not capable of operation with OA down to this temperature will not be accepted.**

Evaporator Dehumidifier Coil:

Fins shall be die formed, lanced, aluminum with extruded fin collars to provide maximum heat transfer, and shall be damage resistant. Fin spacing shall be 10 FPI (fins per inch) [3.94 fins per 10 mm]. Coil tubing shall be fabricated from seamless drawn copper. The inner tubing shall be rifled to produce turbulent refrigeration flow and to enhance the heat transfer process. The tubes shall be hydraulically expanded into the fins to form a permanent metal-to-metal bond for maximum heat transfer and stability. The coil shall be six (6) rows deep. All air coils shall be leak tested with 420-psig (2,896 kPa) nitrogen. After testing, coils must be sealed.

Optional Coil Coating: Coils will be protected with Electrofin E-coating to resist chemicals and corrosion. The coating shall be applied to both the tubing and fins. The coil must be sealed, electrostatically charged and dip-coated.

Condenser (Reheat Coil):

The reheat coil shall be positioned with a 5" minimum clearance from the DX coil to water re-evaporation. **Direct connection of the reheat coil to the DX coil is not allowed.** Fins shall be die-formed, aluminum with extruded fin collars to provide maximum heat transfer, and shall be damage-resistant. Fin spacing shall be 12 FPI (fins per inch) [4.72 fins per 10 mm]. Coil tubing shall be fabricated from seamless drawn copper. The tubes shall be hydraulically expanded into the fins to form a permanent metal-to-metal bond for maximum heat transfer and stability. The coil shall be a minimum of two (2) rows deep. All air coils shall be leak tested with 420-psig (2,896 kPa) nitrogen. After testing, coils must be sealed.

Optional Coil Coating: Coils will be protected with Electrofin E-coating to resist chemicals and corrosion. The coating shall be applied to both the tubing and fins. The coil must be sealed, electrostatically charged and dip-coated.

Water Condenser and Water to Refrigerant Evaporator:

This WSHP unit(s) shall be equipped with two (2) brazed plate water to refrigerant heat exchangers. The plate water to refrigerant evaporator shall be piped in series with the water condenser. The water condenser must be first in series with respect to incoming water flow from the water loop. The water to refrigerant condenser allows the refrigerant energy to be released into the water loop during cooling operation and it also shall operate as a condenser in the heat pump heating mode to discharge any overage of compressor energy generated and not needed to control unit Leaving Air Temperature (LAT). In the heat pump heating mode the excess of refrigerant energy will discharged into the water loop and acts as a water heating "supercharger" heating the water before the water to refrigerant evaporator extracts the energy for heating (heat of extraction). This process is patented.

The system shall be designed for simultaneous heat of rejection to both the hot gas reheat coil and the water condenser while controlling the LAT within $\pm 0.2^\circ\text{F}$ ($\pm 0.1^\circ\text{C}$).

The plate water to refrigerant evaporator and the plate refrigerant to water condenser shall both be constructed as a brazed plate heat exchanger. The heat exchanger shall consist of stainless steel plates, copper-brazed together to allow a maximum working temperature of 350°F (177°C). The heat exchanger shall be factory leak-tested with helium at 625-psig (4,309 kPa) for quality assurance and, must have a maximum working pressure of 450 psi (3,103 kPa). The brazed plate heat exchangers shall be UL listed.

ClimateMaster works continually to improve its products. As a result, the design and specifications of each product at the time of order may be changed without notice and may not be as described herein. Please contact ClimateMaster's Customer Service Department at 1-405-745-6000 for specific information on the current design and specifications. Statements and other information contained herein are not express warranties and do not form the basis of any bargain between the parties, but are merely ClimateMaster's opinion or commendation of its products. The latest version of this document is available at climatemaster.com.



Genesis HD & RD Engineering Specifications Rev.: 02/06/09 Page 3

The head pressure shall be controlled by the system's internal flooding valve.

Compressor(s):

Compressors: (4 & 5 HP): The compressor shall be a heavy-duty scroll-type, single compressor complete with start kit on single-phase motors. The compressor shall be equipped with low- and high-pressure safety switches, with internal protection from overheating. The compressors shall be externally vibration isolated. A standard factory one (1)-year compressor warranty shall be included. The unit must include hot gas bypass for each system compressor.

Compressors: (8 to 15 HP): The compressors shall be a tandem pair, heavy-duty scroll-type. A factory-mounted sensor that will deactivate one compressor when the load reaches the mid-range of the system's capacity, shall stage the compressors. The compressors must be equipped with high- and low-pressure safety switches, with internal protection from overheating. The compressors shall be externally vibration isolated. A standard factory one (1)-year compressor warranty shall be included. The unit must include hot gas bypass for each system compressor.

Compressors: (>35 HP): The compressors shall be a dual circuit, tandem pair, and heavy-duty scroll type. A factory-mounted sensor that will deactivate each compressor when the load reaches the quarter-range of the system's capacity shall stage the compressors. The compressor shall be in the dehumidifier and equipped with high- and low-pressure safety switches, with internal protection from overheating. The compressor shall be externally vibration isolated. A standard factory one (1)-year compressor warranty shall be included. The unit shall be provided with hot gas bypass for each system circuit. **The use of semi-hermetic compressors is not acceptable.**

Drain Pan:

The drain pan shall be 20-gauge (0.812 mm) stainless steel, sloped, and positioned under the evaporator coil. It shall be silver-solder, welded and securely attached to the evaporator end plates to avoid shifting. The drain pan shall be fitted with a minimum 1" EPT non-corrosive plastic drain connection and an internal P-Trap. The drain pan shall meet all the requirements of ASHRAE 62. Drain pan shall be fully insulated. Drain outlet shall be located at the pan as to allow complete and unobstructed drainage of condensate.

Electrical:

The electrical control panel shall be easily accessible on one side so that all service can be performed from the side of the unit. It shall be of adequate size so as to house all electrical controls and devices.

The unit shall be provided with single-point power connection, factory wired to the power connection lug set.

The electrical controls shall include low voltage transformers to supply 24 VAC control power, clearly labeled high- and low-voltage terminal strips, high- and low-pressure control (with manual reset of the high-pressure cutout and automatic reset of low pressure cutout), and an anti-shortcycling timer delay to protect against compressor cycling.

Option: Disconnect Switch, Non-Fused

Option: Disconnect Switch, Non-Fused with 115 VAC GFI convenience outlet

Controls:

The unit shall include factory mounted temperature and humidity sensors in the filter section, pre-wired to controller in panel for actuation of compressor in ambient temperatures above 55°F (12.7°C) dew point (programmable).

The unit must be supplied with the necessary controls as defined in the unit's Sequence of Operation for proper temperature and humidity control of the space. See plans and/or other documentation for the detailed sequence of operation of this unit.

Warranty:

ClimateMaster shall warranty equipment for a period of 24 months from date of shipment.

Option: Extended 3-year compressor warranty covers compressor for a total of 5 years.



Genesis HW & RW Engineering Specifications Rev.: 02/06/09 Page 1

MODELS "GOHW / GORW" SIZE 03-30 100% OUTDOOR AIR
WATER SOURCE HEAT PUMP with ENERGY RECOVERY WHEEL SPECIFICATIONS
Rev. October 30, 2006

General:

Furnish and install ClimateMaster "Genesis" Model horizontal (HW) / rooftop (RW) high efficient 100% OA Water Source Heat Pumps, as indicated on the plans. Equipment shall be completely assembled, piped and internally wired. The unit shall include the following minimum components: Enthalpy energy recovery wheel, compressor(s), dehumidification/cooling coil, hot gas reheat coil, receiver, supply and exhaust air blowers, blower motors, controls and water cooled condenser and heat pump evaporator. Units shall have Variable Hot Gas Reheat and leaving air temperature control to $\pm 0.2^{\circ}\text{F}$ ($\pm 0.1^{\circ}\text{C}$) in cooling/dehumidification and heating modes. Capacities and characteristics shall be as listed in the schedule and the specifications that follow.

Horizontal / Rooftop 100% OA Water Source Heat Pumps:

Units shall be supplied completely factory built for an entering water temperature range from 35° to 105°F (1.7° to 40.6°C) as standard. Equivalent units from other manufacturers can be proposed provided approval to bid is given 10 days prior to bid closing. All equipment listed in this section must be tested in accordance with American Refrigeration Institute / International Standards Organization (ARI / ISO) and certified in accordance with UL 1995 Second Edition. The units shall have an ETL-US label. All units shall be fully quality tested by factory run testing under design operating conditions and water flow rates as described herein. The following quality control system checks shall be performed: triple leak check, pressure tests, evacuate and accurately charge system, perform detailed heating, dehumidification and cooling mode tests, and hot gas reheat mode testing. **Units tested without water flow are not acceptable.**

Basic Construction:

HW model units shall be constructed for indoor installation and usage. RW model units shall be constructed for outdoor installation and usage and shall include rain hood, low leak outdoor air isolation damper with 24V motorized actuator, and additional weather-stripping for improved weather resistance. The cabinet shall be 1" (25.4mm) double wall construction, 16-gauge (1.5mm) galvaneal outer panels and 22gauge (0.7mm) galvanized metal inner liner. RW model units shall be tested in accordance with UL rain test standards. A 12-gauge (2.5MM) galvanized base rail assembly shall be incorporated with the unit base pan for the base of the unit.

All exterior and other painted surfaces shall be constructed of galvaneal steel with a powder coated painted finished. Painting shall be by a powder coat technique to assure positive adherence with a high-impact finish. All sides of panels shall be painted. The panels shall be rated to meet a minimum of 1,000-hour salt spray test. Unit color shall be light gray. This corrosion protection system shall meet the stringent 1000-hour salt spray test per ASTM B117.

The unit roof shall be constructed as described above with a standing seam construction. All roof edges shall overlap sides of unit and have lip extending away from unit sides so that rainwater drippage shall not fall on top of access doors.

Unit shall be single side access. Access to filters, indoor blower, electrical controls, compressor compartment, and damper section shall be provided by double wall access doors with hinges, and compression latches with non-corrosive handles. All external fasteners shall be stainless steel bolts. **Self-taping or drive screws are unacceptable.**

Bottom base pan of entire unit shall have no penetrations by bolts or screws.

All double wall cabinet panels shall house a 1 inch (25.4mm) thick, solid foam insulation with a minimum "R" factor of 5.0. **Unit insulation must meet these stringent requirements or unit(s) will not be accepted.**

Entire unit base shall be insulated on the underneath side to provide condensation protection, and noise attenuation.

RW Outdoor cabinets shall include a rain hood and low leak isolation dampers with 24v motorized actuator

The unit shall be furnished with 4" (100mm) filter racks on both sides of the ERW and one set 4" (100mm) MERV 8 pleated filters.

Enthalpy Energy Recovery Wheel:

Desiccant Type: Wheel shall be a 4-Angstrom (0.4 nm) or smaller molecular sieve made of porous crystalline aluminosilicates.

Wheel Type: Constructed of a corrugated synthetic fiber-based media impregnated with the desiccant. **Desiccant that is bonded or coated to the matrix shall not be acceptable.**

ClimateMaster works continually to improve its products. As a result, the design and specifications of each product at the time of order may be changed without notice and may not be as described herein. Please contact ClimateMaster's Customer Service Department at 1-405-745-6000 for specific information on the current design and specifications. Statements and other information contained herein are not express warranties and do not form the basis of any bargain between the parties, but are merely ClimateMaster's opinion or commendation of its products. The latest version of this document is available at climatemaster.com.



Genesis HW & RW

Engineering Specifications Rev.: 02/06/09 Page 2

Wheel Frame: Constructed of galvanized spokes and an aluminum hub

Drive System: The motor shall be a fractional horsepower AC drive with a durable multi-link drive belt

Purge: The system shall have an adjustable (0 to 15%) purge section to minimize contaminant carryover

Supply and Exhaust Fan and Motor Assemblies:

The assembly shall include a fan, housing and solid steel fan shaft encased in ball bearings. Unit shall have a belt drive fan assembly, fan pulley and adjustable motor sheave with v-belt drive. Fan shall be forward curved, low speed centrifugal that has been statically and dynamically balanced, and tested in accordance with current A.M.C.A. standards bulletin 210. Fan bearings shall be permanently lubricated type and be self-aligning. The motor shall be single- or three-phase (as specified), high efficiency, ball bearing, open type with internal thermal overload protection. The motor shall be mounted on an adjustable base for proper belt tension. The fan and motor assembly must be capable of overcoming the external static pressures as shown on the schedule. Airflow / Static pressure rating of the unit shall be based on a wet coil and a clean filter in place.

Refrigerant Circuit:

Units shall have a sealed refrigerant circuit including a high efficiency scroll compressor(s) designed for heat pump operation, a thermostatic expansion valve for refrigerant metering, an enhanced corrugated aluminum lanced fin and rifled copper tube refrigerant to air heat exchanger, plate refrigerant to water heat exchanger, plate water to refrigerant evaporator, hot gas reheat / heat pump heating coil, liquid receiver, modulating HGRH controls and safety controls including a high pressure switch, low pressure switch (loss of charge), water coil low temperature sensor, and air coil low temperature sensor. The unit shall be provided with a refrigerant receiver. The receiver will assist the unit in operating at the highest efficiency over the entire operating range of load conditions.

Access fittings shall be factory installed on high and low pressure refrigerant lines to facilitate field service. Activation of any safety device shall prevent compressor operation via a microprocessor lockout circuit. The lockout circuit shall be reset at the contractor supplied disconnect switch. **100% OA WSHP units that utilize a reversing operation shall not be acceptable.**

Unit refrigeration circuit shall allow entering OA as low as 15°F (-9°C) without the use of preheat. **Units not capable of operation with OA down to this temperature will not be accepted.**

Evaporator Dehumidifier Coil:

Fins shall be die formed, lanced, aluminum with extruded fin collars to provide maximum heat transfer, and shall be damage resistant. Fin spacing shall be 10 FPI (fins per inch) [3.94 fins per 10 mm]. Coil tubing shall be fabricated from seamless drawn copper. The inner tubing shall be rifled to produce turbulent refrigeration flow and to enhance the heat transfer process. The tubes shall be hydraulically expanded into the fins to form a permanent metal-to-metal bond for maximum heat transfer and stability. The coil shall be six (6) rows deep. All air coils shall be leak tested with 420-psig (2,896 kPa) nitrogen. After testing, coils must be sealed.

Optional Coil Coating: Coils will be protected with Electrofin E-coating to resist chemicals and corrosion. The coating shall be applied to both the tubing and fins. The coil must be sealed, electrostatically charged and dip-coated.

Condenser (Reheat Coil):

The reheat coil shall be positioned with a 5" (127 mm) minimum clearance from the DX coil to avoid water re-evaporation. **Direct connection of the reheat coil to the DX coil is not allowed.** Fins shall be die-formed, aluminum with extruded fin collars to provide maximum heat transfer, and shall be damage-resistant. Fin spacing shall be 12 FPI (fins per inch) [4.72 fins per 10 mm]. Coil tubing shall be fabricated from seamless drawn copper. The tubes shall be hydraulically expanded into the fins to form a permanent metal-to-metal bond for maximum heat transfer and stability. The coil shall be a minimum of two (2) rows deep. All air coils shall be leak tested with 420-psig (2,896 kPa) nitrogen. After testing, coils must be sealed.

Optional Coil Coating: Coils will be protected with Electrofin E-coating to resist chemicals and corrosion. The coating shall be applied to both the tubing and fins. The coil must be sealed, electrostatically charged and dip-coated.

Water Condenser and Water to Refrigerant Evaporator:

This WSHP unit(s) shall be equipped with two (2) brazed plate water to refrigerant heat exchangers. The plate water to refrigerant evaporator shall be piped in series with the water condenser. The water condenser must be first in series with respect to incoming water flow from the water loop. The water to refrigerant condenser allows the refrigerant energy to be released into the water

ClimateMaster works continually to improve its products. As a result, the design and specifications of each product at the time of order may be changed without notice and may not be as described herein. Please contact ClimateMaster's Customer Service Department at 1-405-745-6000 for specific information on the current design and specifications. Statements and other information contained herein are not express warranties and do not form the basis of any bargain between the parties, but are merely ClimateMaster's opinion or commendation of its products. The latest version of this document is available at climatemaster.com.

Genesis HW & RW

Engineering Specifications Rev.: 02/06/09 Page 3

loop during cooling operation and it also shall operate as a condenser in the heat pump heating mode to discharge any overage of compressor energy generated and not needed to control unit Leaving Air Temperature (LAT). In the heat pump heating mode the excess of refrigerant energy will be discharged into the water loop and acts as a water heating "supercharger" heating the water before the water to refrigerant evaporator extracts the energy for heating (heat of extraction). This process is patented.

The system shall be designed for simultaneous heat of rejection to both the hot gas reheat coil and the water condenser while controlling the LAT within $\pm 0.2^{\circ}\text{F}$ ($\pm 0.1^{\circ}\text{C}$).

The plate water to refrigerant evaporator and the plate refrigerant to water condenser shall both be constructed as a brazed plate heat exchanger. The heat exchanger shall consist of stainless steel plates, copper-brazed together to allow a maximum working temperature of 350°F (177°C). The heat exchanger shall be factory leak-tested with helium at 625-psig (4,309 kPa) for quality assurance and, must have a maximum working pressure of 450 psi (3,103 kPa). The brazed plate heat exchangers shall be UL listed.

The head pressure shall be controlled by the system's internal flooding valve.

Compressor(s):

Compressors: (3 to 5 HP): The compressor shall be a heavy-duty scroll-type, single compressor complete with start kit on single-phase motors. The compressor shall be equipped with low- and high-pressure safety switches, with internal protection from overheating. The compressors shall be externally vibration isolated. A standard factory two (2)-year compressor warranty shall be included. The unit must include hot gas bypass for each system compressor.

Compressors: (8 to 30 HP): The compressors shall be a tandem pair, heavy-duty scroll-type. A factory-mounted sensor that will deactivate one compressor when the load reaches the mid-range of the system's capacity, shall stage the compressors. The compressors must be equipped with high- and low-pressure safety switches, with internal protection from overheating. The compressors shall be externally vibration isolated. A standard factory two (2)-year compressor warranty shall be included. The unit must include hot gas bypass for each system compressor.

Drain Pan:

The drain pan shall be 20-gauge (0.812 mm) stainless steel, sloped, and positioned under the evaporator coil. It shall be silver-solder, welded and securely attached to the evaporator end plates to avoid shifting. The drain pan shall be fitted with a minimum 1" EPT non-corrosive plastic drain connection and an internal P-Trap. The drain pan shall meet all the requirements of ASHRAE 62. Drain pan shall be fully insulated. Drain outlet shall be located at the pan as to allow complete and unobstructed drainage of condensate.

Electrical:

The electrical control panel shall be easily accessible on one side so that all service can be performed from the side of the unit. It shall be of adequate size so as to house all electrical controls and devices.

The unit shall be provided with single-point power connection, factory wired to the power connection lug set.

The electrical controls shall include low voltage transformers to supply 24 VAC control power, clearly labeled high- and low-voltage terminal strips, high- and low-pressure control (with manual reset of the high-pressure cutout and automatic reset of low pressure cutout), and an anti-shortcycling timer delay to protect against compressor cycling.

Option: Disconnect Switch, Non-Fused

Option: Disconnect Switch, Non-Fused with 115 VAC GFI convenience outlet

Controls:

The unit shall include factory mounted temperature and humidity sensors in the filter section, pre-wired to controller in panel for actuation of compressor in ambient temperatures above 55°F (12.7°C) dew point (programmable).

The unit must be supplied with the necessary controls as defined in the unit's Sequence of Operation for proper temperature and humidity control of the space. See plans and/or other documentation for the detailed sequence of operation of this unit.

Warranty:

ClimateMaster shall warranty equipment for a period of 24 months from date of shipment.

Option: Extended 3-year compressor warranty covers compressor for a total of 5 years.

GO Series 60Hz - R22 Submittal Data Eng/I-P



Revision History

Date:	Item:	Action:
4 June, 2009	Stand-Alone and Big Book Submittals	Consolidated
6 Feb, 2009	Engineering Specifications	Updated
25 July, 2008	Blower Motor and Wheel Table	Added
25 April, 2008	Data Models	Consolidated
23 April, 2008	Decoder	Updated
18 April, 2008	Physical Data Tables	Added
18 April, 2008	Horizontal Data	Consolidated Tables
18 April, 2008	Nomenclature Page	Added Table
08 Nov, 2007	Specifications	Updated
08 Nov, 2007	Controls	Updated
08 Nov, 2007	Sequence of Operation	Updated
08 Nov, 2007	Dimensional Data	Updated
08 Nov, 2007	Blower Data	Updated and reformatted
30 Oct, 2006	Specifications	Updated
01 Sep, 2006	First Published	