**Vertical Hi-Rise Series
Water Source Heat Pumps**

**Installation, Operating &
Maintenance Instructions**

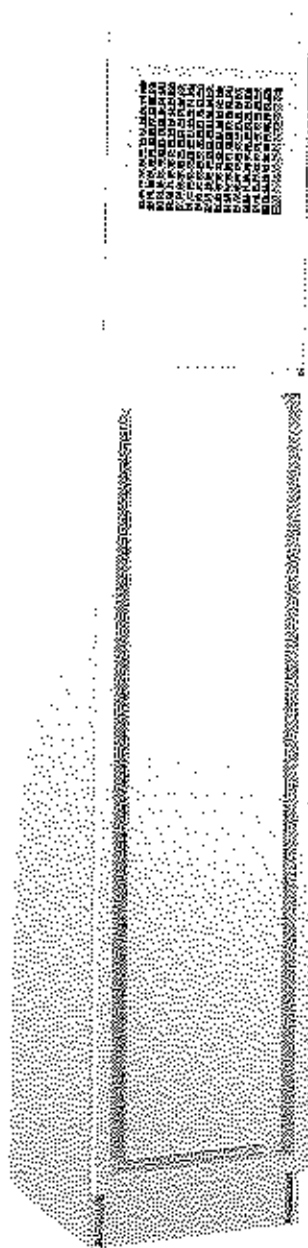

TABLE OF CONTENTS

	Page
General Information	3
Inspection	3
Introduction	3
Storage	3
Unit Protection	3
Pre-Installation	3
Installation	4
Supply and Return Piping	4
Condensate Piping	4
Riser Connections	4
Electrical Wiring	5
Installation of Optional Wall Mounted Thermostat	6
Wall Board Installation	7
Optional Duct Installation	7
Chassis Installation	7
Supply Grille Installation	8
Start-Up Preparation	8
System Checkout	10
Unit Start-Up	11
Balancing Water Flow	12
Adjusting Fan Speed	12
Operating Controls	12
Maintenance	13

GENERAL INFORMATION

Inspection

Upon receipt of shipment, carefully check the shipment against the bill of lading. Verify that all VHS units have been received. Inspect each unit for damage. Assure that the carrier makes proper notation on the delivery receipt of all shortages and damage identified and that he completes a Carrier Inspection Report. Concealed damage not discovered during unloading must be reported to the carrier within fifteen (15) days of receipt of shipment. **NOTE: It is the responsibility of the purchaser to file all necessary claims with the carrier.** Notify the ClimateMaster Traffic Department within fifteen (15) days of receipt of shipment of all damage. VHS Units are shipped in three cartons: one for the cabinet assembly, one for the chassis assembly and one for the front panel.

Introduction

ClimateMaster Vertical Hi-Rise Air Conditioner Water Source Heat Pump units are decentralized room terminals designed for field connection to a closed-circuit piping loop.

VHS Units are typically installed in perimeter zones and are usually framed in place. A discharge plenum with single or multiple air discharge options eliminates the need for duct work in most applications.

Unit electrical data is provided in the project submittal drawings.

Storage

▲ WARNING

DO NOT store or install VHS units in corrosive environments or in locations subject to temperature or humidity extremes (e.g., attics, garages, rooftops, etc.). Corrosive conditions and high temperature or humidity can significantly reduce performance, reliability, and service life.

Upon the arrival of the equipment at the job site, immediately store units in their shipping cartons in a clean, dry area. Always move units in an upright position. Tilting units on their sides may cause equipment damage. Store units in an upright position at all times. Do not stack equipment. **Do not remove equipment from shipping cartons until equipment is required for installation.**

Unit Protection

Cover VHS units on the job site with either shipping cartons, vinyl film, or an equivalent protective covering. Cap the open ends of pipes stored on the job site. In areas

where painting, plastering, or the spraying of fireproof material has not been completed, all due precautions must be taken to avoid physical damage to the units and contamination by foreign material. Physical damage and contamination may prevent proper start-up and may result in costly equipment clean-up.

Examine all pipes, fittings, and valves before installing the system components. Remove any dirt found on these components.

All cabinets may not be equipped with the same size riser or the same air supply grille arrangement. Carefully inspect each unit before delivery to the installation site. In some cases each cabinet may be individually tagged for a specific location in the building.

▲ WARNING

To avoid equipment damage, do not use these units as a source of heat during construction process. The mechanical components and filters used in these units quickly become clogged with construction dirt and debris which may cause system damage and necessitate costly unit clean-up.

Pre-installation

Installation, operation and maintenance instructions are provided with each unit. Before unit start-up, read all manuals and become familiar with the unit and its operation. Thoroughly check out the system before operation. Complete the inspections and instructions listed below to prepare a VHS unit for installation.

1. Compare the electrical data on the unit nameplate with ordering and shipping information to verify that the correct unit has been shipped.
2. Keep the equipment covered with the shipping carton until all plastering, painting, and finish work is complete and it is time to install the cabinet and chassis.
3. Match unit chassis to proper cabinets.
4. Verify that the refrigerant tubing is free of kinks or dents, and that it does not touch other unit components.
5. Inspect all electrical connections. Connections must be clean and tight at the terminals.
6. Inspect blower assembly and manually rotate fan wheel to assure that it turns freely.

NOTE: Compressors of VHS Units are internally spring mounted. No hold-down bolts need to be removed.

INSTALLATION

The installation of Vertical Hi-Rise Air Conditioner Water Source Heat Pumps and all associated components, parts and accessories that make up the installation shall be in accordance with the regulations of ALL Authorities having jurisdiction and MUST conform to all applicable Code. It is the responsibility of the Installing Contractor to determine and comply with ALL applicable Code and Regulations.

A WARNING

To avoid damage from clogged coil surfaces, clogged motor ventilation openings, seized fan blades and potential unit failure, **DO NOT OPERATE UNIT without complete enclosure, supply grille, return air grille and filter place.**

Supply and Return Piping

1. Install a drain valve, shut-off/balancing valves, flow indicators and drain tees at the base of each supply and return riser to enable system flushing at start-up, balancing and during servicing.
2. Install strainers at the inlet of each circulating pump.
3. Insulate loop water piping which runs through nonconditioned areas or outside the building. Because loop temperature is normally between 60° F and 90° F, piping does not sweat or suffer heat loss under ambient conditions.

Condensate Piping

Condensate connection between the drain pan assembly and condensate riser is factory installed and trapped in VHS units.

Riser Connections

Install Cabinet Risers as follows:

1. In applications supplemented with factory (or field) supplied between the floor riser extensions, assemble and install extensions before installing cabinet. **NOTE:** Riser assemblies are designed to accommodate a maximum of 1-1/2" expansion and contraction up to a total movement of 3". If the total calculated riser expansion exceeds 3", expansion devices must be provided.

NOTE: All riser modifications necessitated by variations in floor-to-floor dimensions including cutting off or extending risers is the sole responsibility of the installing contractor.

2. Move cabinet into position. **CAUTION:** Keep risers off the floor while moving cabinet.

3. Raise the cabinet upright and lower it into the riser from the floor below. **NOTE:** The top of each riser is equipped with a 3" swaged section. There is sufficient extension at the bottom to allow insertion of approximately 2" of the riser into the swaged top of the riser below.

A CAUTION

CAUTION: To ensure correct riser positioning and to compensate for variations in floor-to-floor dimensions, do not allow the unit-to-unit riser joint to bottom out.

4. Center risers in the pipe chase and shim the cabinet level. Plumb risers in two planes to assure proper unit operation and condensate drainage.
5. Attach the cabinet assembly to the floor and the building structure on at least two sides using sheet metal angles. Additional anchorage can be provided by installing brackets at the top of the cabinet. Brackets also simplify wall board installation around the cabinet.

When all units on a riser are anchored into place, complete riser joints as follows:

1. Center the horizontal supply and return runouts in the expansion slots provided in the back panel of the cabinet assembly. Assure that runouts are perpendicular to the back panel.
2. Verify that all riser joints are vertically aligned and that risers penetrate at least one inch into the swaged joint of the riser below. **DO NOT let riser joint bottom out.**
3. Braze riser joints with a high-temperature alloy (such as Phos-copper or Silfos). Soft solder (50-50, 60-40 or 85-15) or low-temperature alloys are not suitable for this application.
4. Anchor built-in risers to the building structure with at least one contact point. To accommodate vertical expansion and contraction **DO NOT** fasten risers rigidly within the unit.
5. Verify that unit shut-off valves are closed. **DO NOT OPEN VALVES until the system has been cleaned and flushed.**
6. To facilitate cleaning and flushing, install a valve loop between risers at the end farthest from the pump. Open valve when fresh water is pumped through the system and close when the system is clean.

NOTE: Refer to System Flushing Section of this manual for more information.

7. Install vents in piping loop as required to bleed the system of air accumulated during installation.

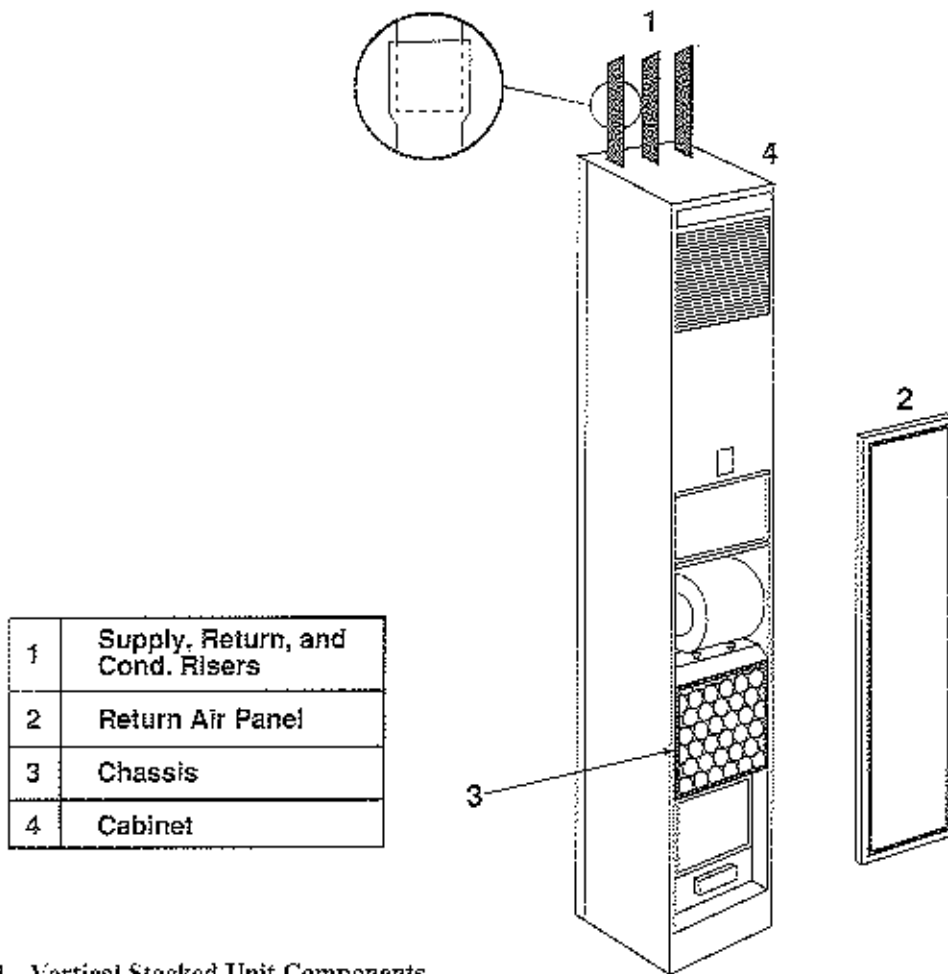

Figure 1 - Vertical Stacked Unit Components

ELECTRICAL WIRING

▲ WARNING

To avoid possible injury or death due to electrical shock, open the power supply disconnect switch and secure it in an open position during installation.

CAUTION: Use only copper conductors for field installed electrical wiring. Unit terminals are not designed to accept other types of conductors.

All field installed wiring, including the electrical ground, MUST comply with the National Electrical Code as well as applicable local codes. In addition, all field wiring must conform to the Class II temperature limitations described in the NEC.

Consult the unit wiring diagram located on the inside of the compressor access panel to ensure proper electrical hookup.

Route power wiring to the unit control panel through the factory installed conduit at the top of the cabinet. Size wiring to handle circuit ampacity marked on the unit nameplate.

Units are shipped wired for 208 Volts. Rewire the control transformer (if supplied) if the actual voltage is 230 Volts. Refer to the unit wiring diagram for details of this procedure.

Use the information provided on the nameplate to determine maximum fuse or circuit breaker size required to protect the unit.

Table 1 - Operating Voltages

	Operating Range
115/60/1	104 Volts min - 127 Volts max
208/230/60/1	197 Volts min - 250 Volts max
265/60/1	238 Volts min - 292 Volts max

Installation of Optional Wall-Mounted Thermostat

The unit can be furnished with a 24-volt surface mounted ACO or MCO control circuit or a remote 24-volt ACO or MCO thermostat. A typical field connection diagram is shown in Figure 2. Refer to instructions provided with remote thermostat for wiring instructions.

Zone integrity must be maintained to efficiently control units or groups of units. Unless zones of control are considered and accounted for, adjacent units may operate in heating and cooling modes simultaneously.

Low-voltage wiring between the unit and the wall thermostat must comply with all applicable electrical codes (i.e., NEC and local codes), and be completed before the unit is installed. Use of four-wire, color-coded, low-voltage cable is recommended.

ACO wall thermostats may require field installation of two jumper wires between terminals RC and R11 and between W2 and Y1. Check the wiring diagram to determine if jumpers are required.

Table 2 below lists recommended wire sizes and lengths to install the thermostat. The total resistance of low-voltage wiring must not exceed 1 ohm. Any resistance in excess of 1 ohm may cause the control to malfunction because of high voltage drop.

Set heat anticipator for MCO thermostats to 0.4 amps. Set first stage heat anticipator for ACO thermostats to 1.0 amps and second-stage heat anticipator for 0.4 amps.

Table 2 - Recommended Thermostat Wire Sizes

WIRE SIZE	MAX. WIRE LENGTH*
22-Gauge	30 Feet
20-Gauge	50 Feet
18-Gauge	75 Feet
16-Gauge	125 Feet
14-Gauge	200 Feet

*Length = Physical distance from thermostat to unit.

Figure 2 - Typical VHS Field Connections for units with Wall-Mounted 24V Thermostat

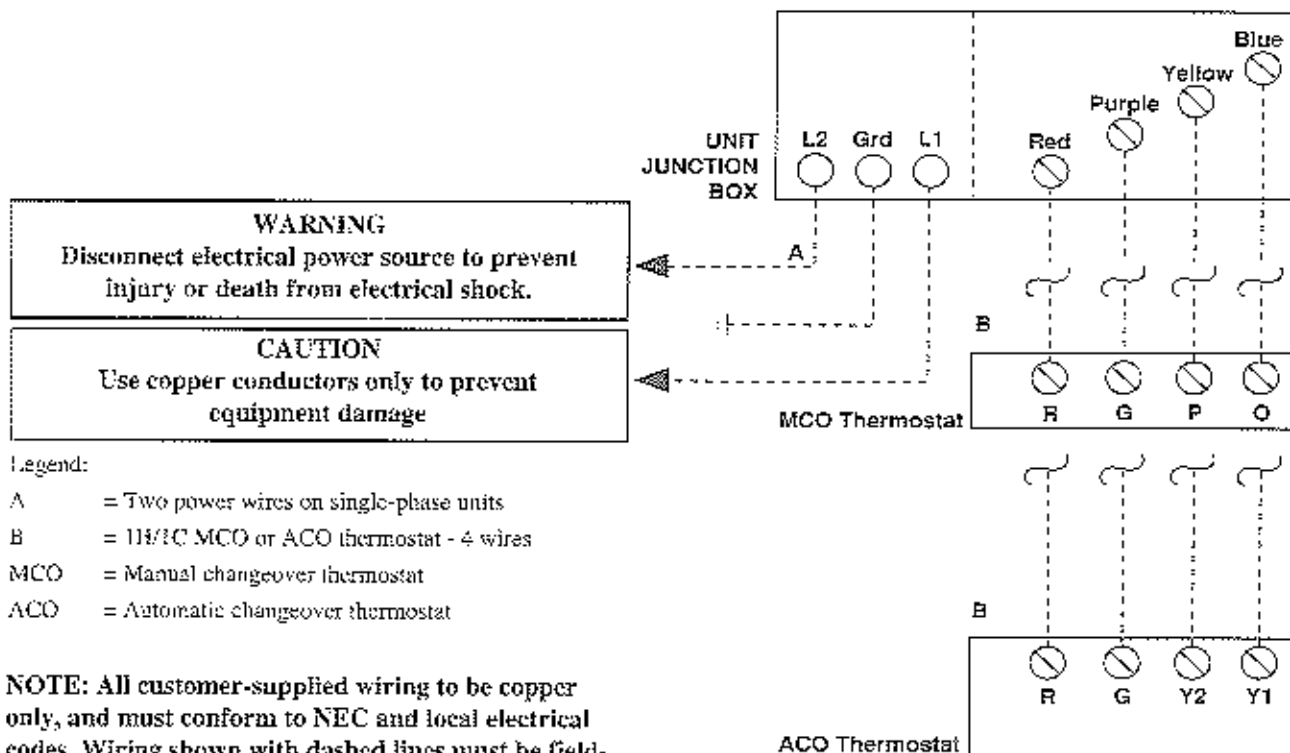

Wallboard Installation

Install wallboard using conventional construction methods. Secure drywall to studs with low profile, pan-head sheet metal screws. Wallboard need not be fastened to drain pan edges or control box enclosure. Do not install wallboard using adhesive alone.

Vacuum all drywall dust and construction debris from coils, drain pans and blower discharge plenum after cutting out supply and return holes for grilles.

A WARNING

To prevent electrical shorts and drain pan leaks, assure that screws do not penetrate unit components when driving screws near the unit control box or drain pan. Do not allow screws or nails to penetrate chassis, risers, electrical junction boxes, raceways or to interfere with chassis removal.

To avoid motor or compressor damage, keep drywall dust out of the unit.

When installation is complete, cover cabinet supply and return air openings. (Cardboard from unit shipping cartons can be used).

Do not allow paint or wall texture over-spray to contact coil, fan or other unit components. Warranties are void if paint or other foreign debris is allowed to contaminate internal unit components.

Optional Duct Installation

When return air is required to enter the unit through openings in a stud wall, supply and field install an optional duct. Seal duct against the return air grille. Add a blockoff above and below the chassis to ensure that all air entering the unit passes through the filter and refrigerant-to-air coil.

Chassis Installation

Install the VHS Chassis as follows:

1. Slide chassis into the cabinet until the front chassis flange mates with the cabinet flange to form an air-tight seal.
2. Minimize sound transmission by centering the chassis left to right. Do not allow chassis to be twisted on the cabinet rails.
3. Connect water coil pipe units. Do not over tighten these connections. Avoid stripping the threads.
4. Install optional field supplied hose kits to link supply and return runouts to the water coil.

5. Verify that the shut-off/balancing valve in the return line and the shut-off valve in the supply line are closed.
6. Flush system following the procedure in Preparation for Start-up Section of this manual.
7. When the system is clean and flushed, open the unit water valves and check piping for leaks.
8. A flexible electrical cable terminating in quick-connect plugs is provide in chassis.
9. Complete electrical connections between cabinet and chassis by mating the quick-connect plugs on the chassis cable to the plugs located at the ends of wires terminating at the cabinet (located to the left of the cabinet control box).
10. Install the air filter in the chassis by inserting the top edge of the filter into the top filter bracket. Push filter up until the bottom can be pushed into place, then lower the filter into the bottom bracket.
11. Before installing the return air/access panel, perform the following checks:
 - a. Ensure that fan wheel rotates freely and does not rub against housing. If rough handling during shipping has caused fan wheel to shift, adjust as necessary.
 - b. Verify that water piping connections to the chassis are complete and that unit service valves which were closed during flushing have been opened.
 - c. Verify that power between the cabinet and chassis is properly connected.
 - d. Assure that the unit drain is properly positioned, secured and not blocked.
 - e. Verify that the nuts used to secure the blower assembly to the fan deck are tight.
12. Install the cabinet return air/access panel. See installation instructions shipped with return air/access panel for detailed information.

Supply Grille Installation

Refer to Table 3 to determine grille size based on the type and size of the supply air grille.

Install supply grilles over the cabinet discharge openings as follows:

- a. Insert the grille into the cabinet discharge opening. Assure that the grille flange rests against the drywall covering the cabinet.
- b. Secure the grille to the cabinet with the screws provided.

Table 3 - Supply Grille Sizes and Arrangements (3)

Unit Size	Single Discharge (1)	Double Discharge (2)	Triple Discharge (3)
VHS-10	12" x 10"	10" x 6"	Not Recommended
VHS-15	12" x 12"	10" x 6"	Not Recommended
VHS-20	14" x 14"	14" x 8"	14" x 6"
VHS-28	Not Recommended	16" x 10"	16" x 6"
VHS-30	Not Recommended	16" x 12"	16" x 8"
VHS-36	Not Recommended	16" x 14"	16" x 10"

(1) Side to front

(2) Any combination of top-ducted, side or front

(3) Grille sizes and arrangements are based on an equal CFM through each grille

START-UP PREPARATION

System Cleaning and Flushing

Cleaning and flushing the unit is the single most important step to ensure proper start-up and continued efficient operation of the system. Follow the instructions below to properly clean and flush the system:

▲ WARNING

To prevent injury or death due to electrical shock or contact with moving part, open unit disconnect before servicing unit.

- Verify that electrical power to the unit is disconnected and that the heat rejector is de-energized
 - Verify that supply and return riser service valves are closed at each unit.
 - Fill the system with water, leaving the air vents open. Bleed all air from the system but do not allow the system to over flow. Check the system for leaks and make any required repairs.
 - Adjust the water and air level in the expansion tank.
 - With strainers in place, start the pumps. Systematically check each vent to ensure that all of the air is bled from the system.
 - Verify that make-up water is available and adjusted to properly replace any space remaining when all air is evacuated. Check the system for leaks and make any additional repairs required.
 - Set the boiler to raise the loop temperature to approximately 85° F. Open the drain at the lowest point in the system. Verify that make-up water replacement rate equals rate of bleed. Continue to bleed the system until the water appears clean or for at least three hours whichever is longer.
 - Completely drain the system.
- Flush risers as follows: (Refer to Figure 3 below).
- Close shut-off valves at each unit on the riser except the shut-off valve on the top floor.
 - At the top floor, use a hose or piping to connect the supply and return runouts together.

3. Flush solution through supply riser. **Note:** The solution passes through the top floor connection down the return riser.
4. When the building has more than 10 floors, connect the supply and return runouts on the top two floors to divide the water flow and reduce pressure drop at the pump.
5. Repeat flushing procedure for each set of risers in the building.
8. Refill the system and add in a proportion of approximately one pound per 150 gallons of water. Reset the boiler to raise the loop temperature to about 100° F.

CAUTION: To avoid possible damage to piping systems constructed of plastic piping, **DO NOT** allow loop temperature to exceed 110° F.

9. Circulate the solution for between 8 to 24 hours. At the end of this period, shut off the circulating pump and drain the solution. Repeat system cleaning if desired.
10. Open the supply and return riser service valves at each unit. Refill the system and bleed off all air.
11. Test the system pH with litmus paper. The system water should be slightly alkaline (pH 7.5 to 8.5). Add chemicals as appropriate to maintain acidity levels.

CAUTION: Do Not use "Stop-Leak" or any similar chemical agent in this system. Addition of these chemicals to the loop water can foul the system and can inhibit unit operation.

12. When the system is successfully cleaned, flushed, refilled and bled, check the main system panels, safety cutouts and alarms. Set controls to properly maintain loop temperature.

Figure 3 - Typical piping arrangement for flushing risers.

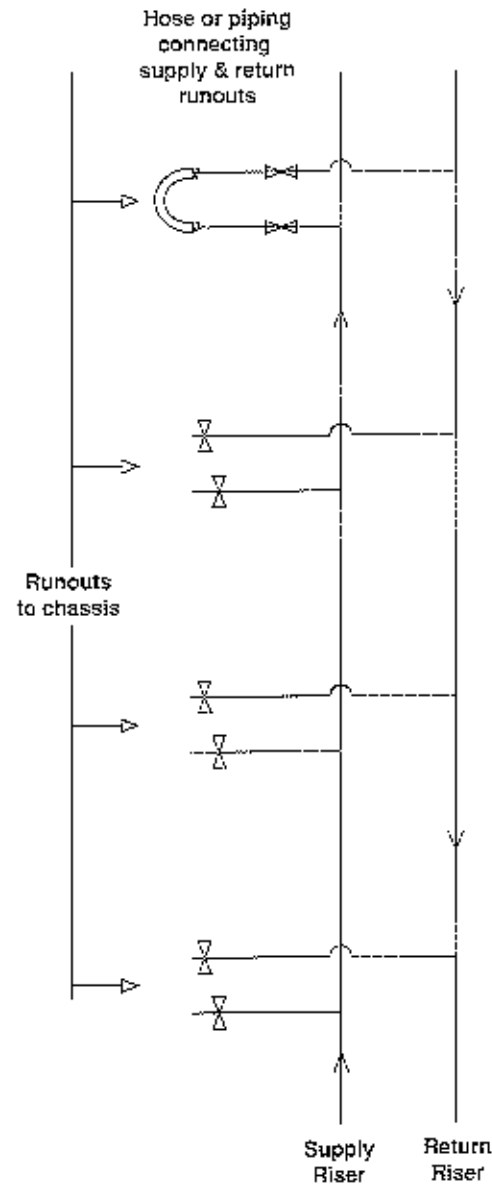

SYSTEM CHECKOUT

When the installation is complete and the system is cleaned and flushed, follow the System Checkout procedure below. Record systems parameters on the *Water Source Heat Pump Start-Up and Inspection Sheet* on page 14. The installing contractor should also complete the abbreviated "Installation Checklist"

- ❑ 1. **Voltage Check:** Ensure that voltage is within the utilization range specifications of the unit compressor and fan motor.
- ❑ 2. **System Water Temperature:** Referring to Table 4, ensure that system water temperature is within an acceptable range to facilitate start-up; (When conducting this check, be sure to verify the proper heating and cooling set-points as well).
- ❑ 3. **System Water pH:** Verify that system water exhibits an approximately neutral balance (i.e., a pH of 7.5 or 8.5); this extends the life of the hoses and heat exchangers.
- ❑ 4. **System Flushing:** Proper system cleaning and flushing is the most important aspect of the start-up procedure for water source heat pump installations. Make sure that the system has been flushed properly, with all supply and return risers closed. This prevents fouling of the unit heat exchangers by system water.

Water used in the system must be clear city water with no visible dirt, piping slug, or chemical cleaning agents apparent.
- ❑ 5. **Closed-Type Cooling Tower (or Open Tower w/Heat Exchanger):** Required to ensure continued cleanliness of the system water, while providing the means for removing excess heat from the building. Check equipment for proper temperature set points and operation.
- ❑ 6. **Balanced Water Flow Rate to Heat Pump:** Verify that as each heat pump unit is installed, inlet and outlet water temperatures are recorded. Refer to the "WSHP System Start-Up/Inspection Sheet."

This check eliminates nuisance unit trip-outs resulting from water velocities that are either too low or too high. It can also prevent the occurrence of erosive water flow rates.
- ❑ 7. **Standby Pump Installed:** Each system must have a standby pump for proper sequencing and operation.
- ❑ 8. **System Controls Operational:** Verify that the system controls are functioning and providing the proper sequencing; this check is necessary to ensure that no catastrophic system failures occur (e.g., frozen cooling towers or heat exchangers, nuisance system shutdowns, etc.)
- ❑ 9. **Freeze Protection from Water System:** Ensure that freeze protection is provided for the outdoor portion of the loop water system. Inadequate freeze protection can lead to extremely expensive tower and system piping repairs.

NOTE: A problem commonly associated with this type of system occurs when it is filled during construction for the purpose of cleaning, flushing and testing. After testing is complete and the system is drained, the building is often left without heat during winter conditions. Since the condenser coils never fully drain by themselves, they can freeze unless glycol is added to the system. Add glycol in areas where winter conditions prevail.
- ❑ 10. **System Water Loop Free of Air:** Verify that all air is removed from the system. (Air in the system impairs unit operation and can cause corrosion in the system piping.)
- ❑ 11. **Unit Filters Clean:** Check to ensure that unit filter is clean. This contributes to the proper operation of the unit by ensuring adequate airflow across the coil.

ClimateMaster recommends that the contractor clean or install a new filter in each unit shortly after initial unit start-up. In addition, use a vacuum to remove any debris or dirt lodged in or on the units.
- ❑ 12. **Check Units Fans for Free Rotation:** Manually rotate fans to make sure that they rotate freely, and that they are secured properly to the fan shaft. fan motors are factory lubricated. Do not oil on start-up.
- ❑ 13. **System Control Center Installed:** A system control and alarm panel is a necessity to ensure control of the temperature set points for operation of the system's heat rejector and boiler.

Ideally, the panel should also contain both audio and visual indicators for abnormal loop water temperatures or lack of water flow. Provided indicator lights for the primary and standby loop circulator pumps when used.
- ❑ 14. **Miscellaneous:** Note any questionable aspects of the installation.

UNIT START-UP

Use the procedure outlined below to initiate proper unit start-up:

NOTE: This equipment is designed for indoor installation ONLY.

1. Adjust all valves to the full open position and verify that the return air/access panel is installed on all units.
2. Adjust thermostat to OFF position. Close disconnect switches on all units to provide line power.

▲ WARNING

High voltage is present in some areas of the electrical panels with the disconnect switch(es) closed. Be sure to exercise caution when working with energized equipment.

3. Operate each unit first in the cooling mode. Room temperature should be in the normal range (i.e., approximately 70° to 75°F DB, and 61° to 65°F WB). Loop water temperature entering the heat pumps should be at least 55°F, but not in excess of 95° F. Refer to Table 4 for more specific information on the operating parameters of VHS units.

NOTE: Three factors determine the operating limits of a VHS unit - (1) return air temperature, (2) water temperature, and (3) ambient temperature. Whenever any one of these factors is at a minimum or maximum level, the other two factors must be at normal levels to ensure proper unit operation.

- a. Adjust the unit thermostat to the coolest position and set the selector switch to cool. Both the fan and compressor should run.
 - b. Check for cool air delivery at the unit grille a few minutes after the units have begun to operate. List the identification number of any machines that do not function at this time.
 - c. Check the elevation and cleanliness of the condensate lines
4. Operate each heat pump in the heating cycle after checking cooling cycle operation. A time delay prevents the compressor from re-starting for approximately 3 minutes.

NOTE: VHS heat pumps are designed to start heating and operate in an ambient of 40° F, with entering air at 40° F, entering water at 50° F, a minimum return air temperature of 50°F and both entering air and water at the flow rates used in the ARI Standard 320 rating test, for initial start-up in winter. To cold start,

increase boiler temperature to 80° F. When space temperature reaches desired level, return boiler control to 70° F.

- a. Adjust the unit thermostat to the warmest setting and set the selector switch to heat. The blower should start immediately and the compressor should activate after the time delay is complete.
 - b. Once the unit has begun to run, check for warm air delivery at the unit grille. Again the installing contractor must list the serial number of any machine that does not function.
5. Log the unit operating conditions at initial start-up for each unit to establish a permanent operating record.

Trouble Shooting

If the unit fails to operate, conduct the following checks:

1. Check the voltage and current; it should be in accordance with the electrical specifications described on the unit nameplate. A voltage variation of +/- 10% of nameplate utilization voltage is acceptable.
2. Look for wiring errors; check for loose terminal screws where wire connections have been made on both the line- and low-voltage terminal boards.
3. Check for dirty filters; a clogged filter can cause the unit's safety cutouts to stop unit operation.
4. Verify that the supply and return piping is properly connected to the inlet and outlet connections on the unit. When the unit is in the cooling mode under ARI conditions, the leaving water temperature is approximately 10° F warmer than the entering water temperature at 3 GPM/ton.
5. If the fan fails to operate, check to see that the fan wheel turns freely and that it is secured to the shaft. Also, determine whether the fan operates during both the heating and cooling modes.
6. If the checks described above fail to reveal the problem and the unit still fails to operate, contact a trained service technician for proper diagnosis and repair of the equipment.

Table 4 - VHS Operating Limits

Air Limits	Cooling	Heating
Min Ambient Air	50° F	50° F
Rated Ambient Air	80° F	70° F
Max. Ambient Air	100 ° F	85 ° F
Min Entering Air	50° F	50° F
Rated Entering Air db/wb	80/67 ° F	70 ° F
Max Entering Air db/wb	100/83° F	80° F
Water Limits		
Min Entering Water	55° F	55° F
Normal Entering Water	85° F	70° F
Max. Entering Water	95° F	85° F

Note: Minimum Air and Water conditions can only be used at ARI flow rates. Only one maximum or minimum value may be used with VHS Units. All other parameters must be at normal conditions.

Balancing Water Flow

On VHS units with a combination shut-off/balancing valve in the supply or return line, adjust water flow rate through the water coil as follows:

1. Fasten one sensor of a dual-temperature test instrument to the supply (or inlet) water pipe inside the unit. Attach the other sensor to the return pipe.
2. Install the return air/access panel. Use care to avoid damaging the sensor leads of the test instrument.
3. Start the unit in cooling mode using the instructions in Unit Start-Up section of this manual.
4. Note the temperature rise of the water flowing through the unit. Gradually close the balancing/shut-off valve until the desired temperature rise is achieved - typically, 10° F.

NOTE: This water flow rate results in a 6° - 7° F drop in temperature in the heating mode.

Adjusting Fan Speed

Adjust fan speed on units not equipped with a fan speed selector switch as follows:

1. Open the unit electrical disconnect switch.

▲ WARNING

To prevent injury or death due to electrical shock or contact with moving parts, open and lock unit disconnect.

2. Remove the unit front panel and open the control panel.
3. Locate the fan motor leads. Notice that two of the leads (black and red) are fitted with plug connectors.

4. The black lead is factory connected to the fan motor for high speed operation. To operate the fan in low speed, unplug the black lead connector. Install the black lead on the red lead in its place.

NOTE: To ensure proper air delivery in units provided with top-duct supply air connections, the fan must be wired to run at high speed.

Control Operation

Units with wall-mounted thermostats.

Operate VHS units from a remotely located, 24-Volt, wall thermostat as follows:

a. Move the heating and cooling set point levers to the position of the desired comfort level. **NOTE:** the minimum temperature differential between heating and cooling is 3° F.

b. Adjust the thermostat system to switch to the desired mode of operations.

c. Switch positions include:

•**OFF:** Both heating and cooling systems are off. Fan is de-energized if the fan switch is in the AUTO position.

•**AUTO:** Unit automatically heats or cools depending upon the relationship between room temperature and thermostat setpoint.

•**HEAT:** Heating system is automatically controlled by the thermostat. Cooling system is locked out.

•**COOL:** Cooling system is automatically controlled by the thermostat. Heating system is locked out.

d. Position the fan switch in either the ON or AUTO position as desired.

NOTE: When the switch is in the ON position, fan operation is continuous regardless of system switch position. When the switch is in the AUTO position, fan operation cycles with the compressor during heating and cooling operation.

MAINTENANCE

Perform the maintenance procedures outlined below at the intervals indicated.

A WARNING

To prevent injury or death due to electrical shock or contact with moving part, open unit disconnect switch before servicing unit.

1. Inspect filters every three months.

Establish a regular maintenance schedule. Clean filters frequently. Maintenance as needed.

CAUTION: To avoid fouled machinery and extensive unit clean-up, do not operate units without filters in place or use as a temporary heat source during construction.

To remove the filter from the VHS unit, lift the filter up and pull it out of the unit at the bottom. Replace the old filter by sliding the top edge of a new filter up into the rack, then pushing in the bottom of the filter until it drops into place.

2. Check condensate drain pans for algae growth every three months.

If algae growth is apparent, consult a water treatment specialist for proper chemical treatment. The application of an algicide every three months typically eliminates algae problems in most locations.

3. Check fan motors annually.

All ClimateMaster heat pumps are permanently lubricated when shipped from the factory. Do not oil fan motors.

4. Visually inspect units at least once a month.

During inspection, give special attention to hose assemblies. Note any signs of deterioration or cracking, and repair leaks immediately.

5. Conduct an amperage check annually on the compressor and fan motor.

Amperage draw on this equipment should not exceed normal full load or rated load amps by more than 10 percent of the values noted on the unit nameplate. Maintain a log of amperage to detect deterioration prior to component failure.

6. Inspect heat exchangers at least once each year (or more frequently if the unit is located in a "dirty" environment). A dirty heat exchanger can reduce operating capacity and can result in serious equipment problems.

Safety Control Reset

All ClimateMaster heat pumps are furnished with high-pressure, low-pressure and low-temperature cutouts to prevent the machine from operating at abnormal conditions of temperature or water flow.

The high-pressure control used on VHS units is designed to open its contacts at 380 psi and automatically re-close them at 300 psig. The contacts of the low-temperature switch open at 33° F and reclose at 40° F. A lockout electrically linked with these cutouts interrupts unit heating or cooling operation.

The unit must be reset manually. Reset is accomplished adjusting the control (or system) switch to the OFF position and then back to the HEAT or COOL (or AUTO) position as desired. **NOTE:** the VHS may also be reset by opening and closing the circuit breaker.

NOTE: If the unit must be reset more than twice, check the unit for a dirty filter, abnormal entering water temperature, inadequate or excessive water flow, and internal malfunctions. If the unit continues to cutout, contact a trained service technician.



Part #: 69197312



7300 S.W. 44th Street
Oklahoma City, OK 73179
Phone: 405-745-6000
Fax: 405-745-6045
www.climatemaster.com

ClimateMaster works continually to improve its products. As a result, the design and specifications of each product at the time of order may be changed without notice and may not be as described herein. Please contact ClimateMaster's Customer Service Department at 1-405-745-6000 for specific information on the current design and specifications. Statements and other information contained herein are not express warranties and do not form the basis of any bargain between the parties, but are merely ClimateMaster's opinion or commendation of its products.