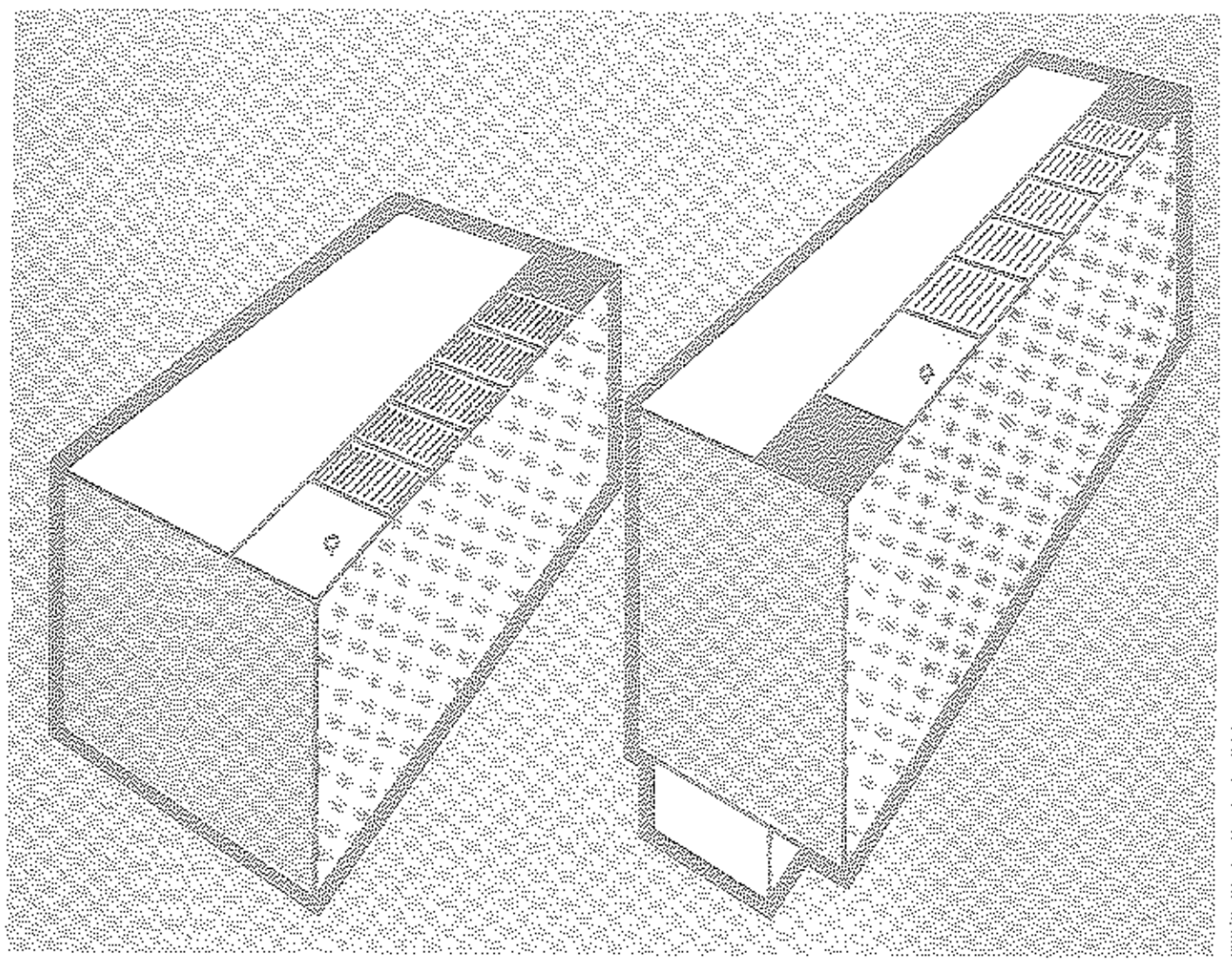


INSTALLATION, OPERATION, MAINTENANCE INSTRUCTIONS



Climate Master 702 SERIES

SP AND MP PACKAGED TERMINAL
AIR CONDITIONERS

50 HERTZ

Friedrich
Climate Master®



TABLE OF CONTENTS

	PAGE
SAFETY	1
DESCRIPTION SP & MP MODELS	1
PRE-INSTALLATION CHECKS	3
INSTALLATION SP CABINET/SLEEVE & CHASSIS	3
INSTALLATION MP WALL BOX, ROOM CABINET & CHASSIS	3
ELECTRICAL CONSIDERATIONS	5
OPERATION	5
ELECTRICAL OPERATING SEQUENCE (702-07 & 702-12)	6
SERVICE	6
MAINTENANCE CHECK LIST	9

SAFETY

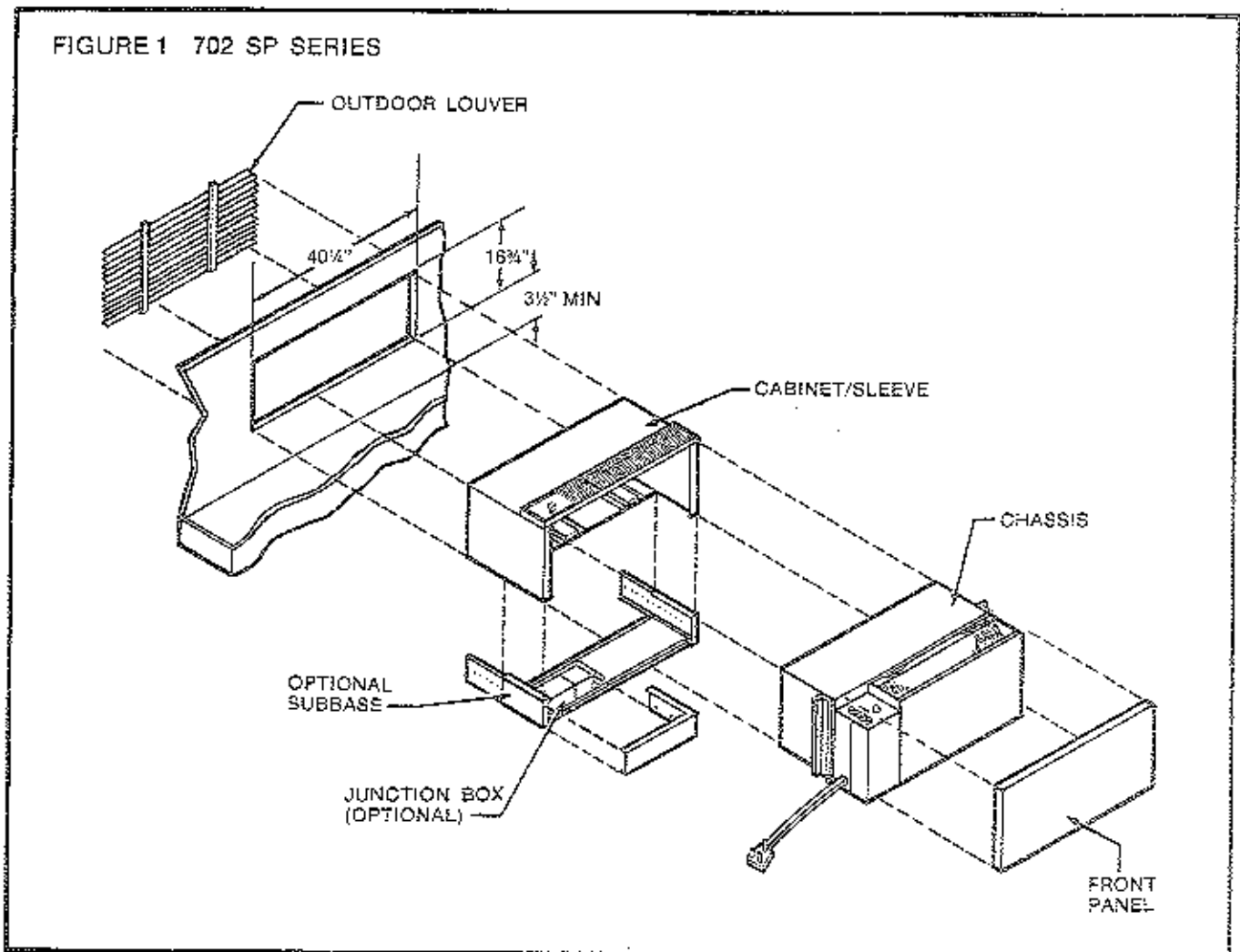
Servicing of our conditioning systems should be performed by qualified personnel only, because of hazards due to electrical components and system pressures. Basic maintenance such as cleaning coils and the replacing of filters can be performed by untrained personnel. When performing service or maintenance on the system, power to the unit should be off. Wear safety goggles and gloves when working with refrigerants. Do not attempt to braze on a system which is under pressure; remove refrigerant first. A quenching cloth, which is used as a heat-sink, is recommended when brazing. Keep a fire extinguisher on hand for all brazing operations.

When using nitrogen and refrigerant for leak testing, always charge the refrigerant in first.

DESCRIPTION

The Friedrich Climate Master 702 Series Packaged Terminal Air Conditioners (PTAC) are thru-the-wall cooling only or combination cooling/heating individual zone air conditioners. The 702 Series is available in two cabinet styles, the SP and MP models. The SP and MP cooling/heating units are provided with a factory installed and wired electric heating element. The MP is available with an optional hydronic heat coil for either hot water or steam heat.

The SP model consists of three sections which are individually packaged; chassis (actual refrigeration system with controls), cabinet/sleeve with front panel, and outdoor louver. (See Figure 1.)



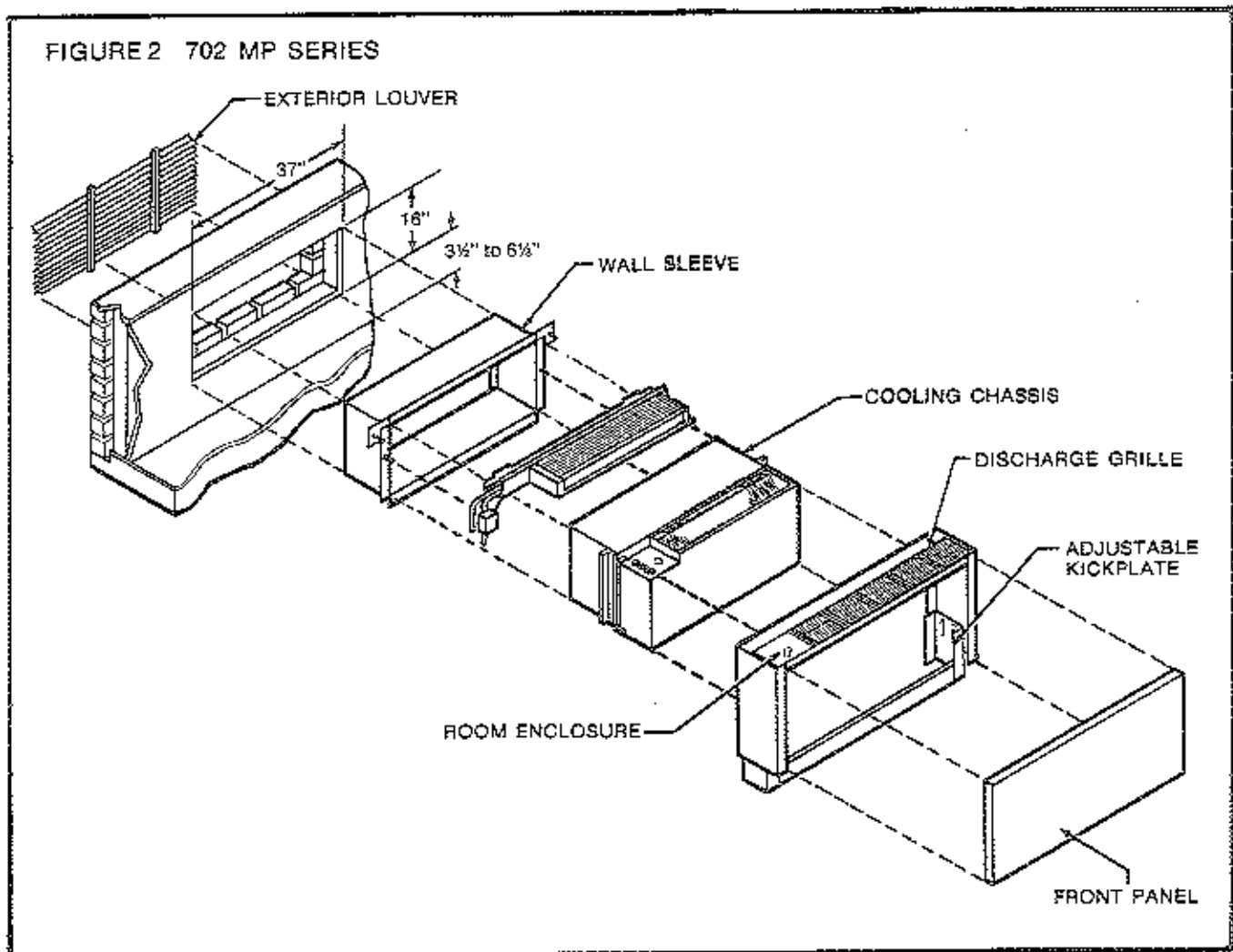
The MP model consists of four sections; wall box, chassis, room cabinet with front panel and outdoor louver. A temporary weather seal is provided with the wall box to protect interiors until installation is complete. (See Figure 2.)

The standard control on both SP and MP models contain an OFF/HIGH COOL/LOW COOL/HEAT and VENT setting plus a self-contained adjustable thermostat with a heat anticipating, discharge feedback feature. The thermostat has two sensing bulbs, one in the discharge air and the other in the entering air to limit both cooling and heating temperature swings.

Positive removal of condensate is provided by evaporation on the condenser coil by means of a multi-blade fan/slinger ring connected directly to the outdoor fan motor.

A fresh air damper is located between the indoor and outdoor sections to provide up to 15% outside ventilation. Motorized or 5 position manually operated dampers are available. All hydronic heat models must specify motorized damper to prevent accidental freezing of the hydronic coil.

The room discharge grilles can be removed and turned to any one of four positions to change direction of airflow.



PRE-INSTALLATION CHECKS

Inspect unit and report any damage or missing parts to the carrier's agent. Request an inspection and a report.

The required wall openings for the SP and MP are shown in Figure 1 and 2. A minimum distance from floor to bottom of wall opening is 3½" to allow for adequate return air.

The SP can be installed in walls ½" to 12" in depth, and will require a factory or field supplied subbase for walls 5" and under. A subbase is also required for SP installations when line cord and receptacle box are specified.

A wall depth of 5" to 25" is required for MP installations.

Verify that the voltage rating on the nameplate matches the power supply.

INSTALLATION CABINET/SLEEVE AND CHASSIS SP (Figure 1)

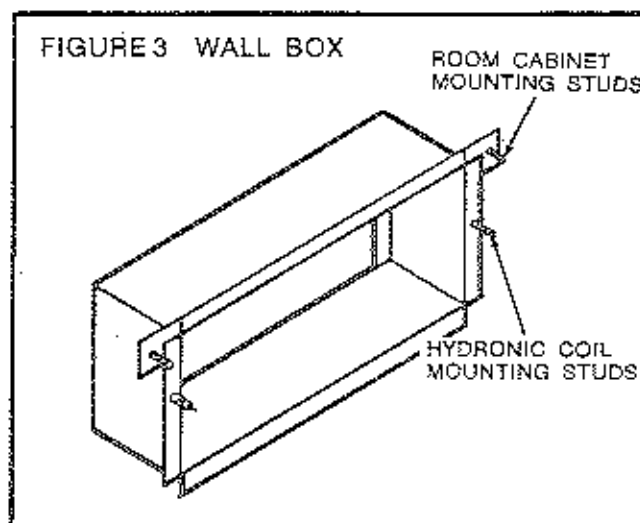
1. Attach subbase (if used) to cabinet/sleeve with (4) screws provided.
2. If optional power connection box is specified, attach to bracket in subbase with (2) screws provided.
3. Install cabinet/sleeve in wall opening, flush with outside wall.
4. Adjust subbase to wall thickness and lock into position with screws provided. Shim vertically if required.
5. Make sure cabinet/sleeve is set horizontally level and vertically plumb. Use top surface and sides of cabinet sleeve for leveling. The base has a built-in-pitch of ¼" to the outside.
6. Secure cabinet/sleeve in wall opening. For masonry wall installation, use masonry anchors. For wood framing, use nails or screws.
7. Caulk between cabinet/sleeve and outside wall for a weather tight seal. Caulking may be necessary between cabinet/sleeve and finished inside wall.

8. Remove temporary weather panel and install outdoor louver. Tie a safety line to the louver, then place the louver (fins facing outdoors and blades downward) through the outdoor opening of the wall box. Pull inward until the louver is squarely seated in recess of cabinet/sleeve. Mount louver using (4) screws supplied.
9. Before installing the chassis, make sure the closed-cell material is attached to the chassis (sides and bottom) for a weather tight seal to the cabinet/sleeve.
10. Install and attach chassis to cabinet/sleeve mounting studs (2) and tighten nuts on studs. Nuts are packed in hardware bag in cooling chassis carton.
11. Attach front panel to (4) metal tabs on cabinet sleeve. To remove, lift up to disengage slots in front panel from metal tabs on cabinet/sleeve.
12. The cabinet may be protected until ready to use by reinstalling the protective cardboard cover supplied as part of the shipping carton.

WALL BOX, ROOM CABINET AND CHASSIS MP (Figure 2)

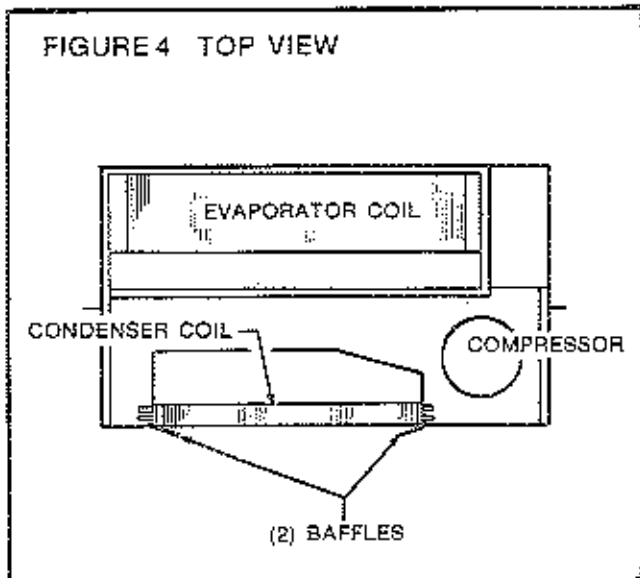
1. Install wall box flush with outside wall. Mounting flange of wall box must never be recessed into finished interior wall. **Do not** remove temporary weather panel while installing wall box. (See Figure 3.)

NOTE: Make certain that correct wall box depth is used at each location as specified in plans.



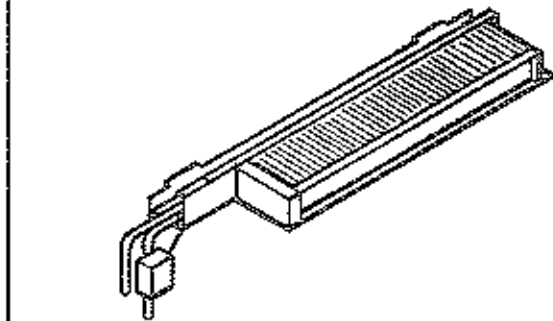
2. Make sure wall box is set horizontally level and vertically plumb. Use top surface and sides of cabinet sleeve for leveling. The base of the wall box has a built in pitch and should **not** be used as a level reference point.
3. Secure wall box in position. Use masonry anchors for masonry wall installation and nails or screws for wood framing.
4. Caulk between wall box and outside wall for a weather tight seal. Caulking may be necessary between wall box and finished inside wall.
5. Install outdoor louver (as previously described in SP Installation).
6. Remove baffles from condenser when the depth of the wall box being installed is greater than 10 inches. Wall boxes larger than 10 inches have baffles factory installed.

NOTE: Do not remove baffles from the condenser when a 10 inch wall box is installed. These baffles prevent air-recirculation of the discharge air. (See Figure 4.)



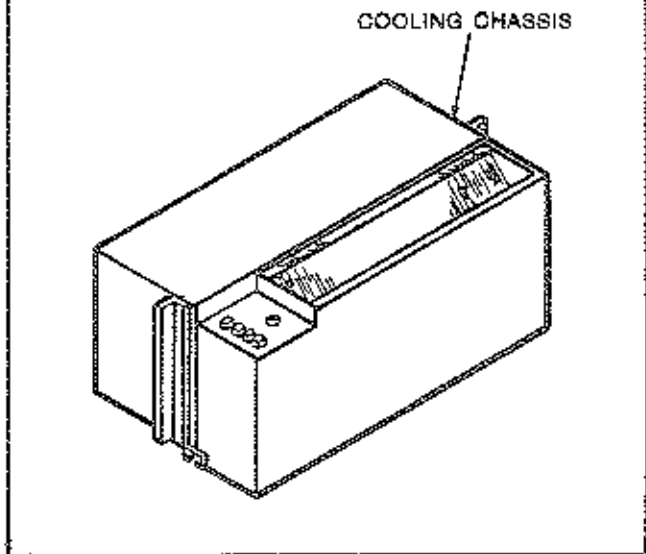
7. Before installing the chassis, make sure the closed-cell material is attached to the chassis (sides and bottom) for a weather tight seal to the wall box.
8. If hydronic coil is specified (see Figure 5), install on wall box mounting studs. (See Figure 3.) Hydronic coil has a metal channel that fits over top flange of wall box.

FIGURE 5 HYDRONIC COIL



9. Install chassis (see Figure 6) on same mounting studs (see Figure 3) as hydronic coil and tighten nuts on studs.

FIGURE 6 CHASSIS

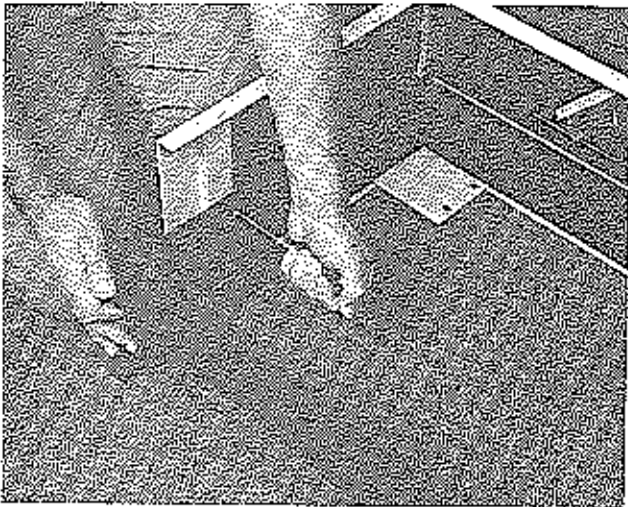


10. Check to see that voltage rating is same on chassis and heat section. Insert male connector from the hydronic coil into the female connector in control module.
11. Remove (4) screws from kickplate and invert. (See Figure 7.) Position kickplate to cabinet mounting flanges and replace screws loosely. (See Figure 8.)

FIGURE 7

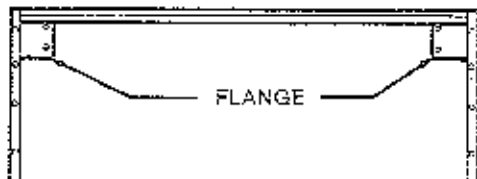


FIGURE 8



12. Attach room cabinet flange (see Figure 9) to wall box mounting studs. Use top hole on each cabinet flange if hydronic coil is not installed. For hydronic coil installations, use bottom hole.

FIGURE 9 ROOM CABINET



13. Locate kickplate in final position and tighten screws.
14. If optional power connection box is specified, mount to front flange of room cabinet with (2) screws provided. Box can be mounted to left or right hand flange, depending on the location of chassis cord.
15. Install front cover (as described previously in SP Installation).
16. Install protective cardboard cover if needed (as described previously in SP Installation).

ELECTRICAL CONSIDERATIONS

All wiring should be in accordance with the National Electric Code and local building codes.

The SP and MP can be either direct connected or supplied with an optional line cord and receptacle box. A field supplied receptacle box can be used for 220 volt electric heat units.

Each unit must have a separate branch circuit protected by a fuse or breaker. Refer to engineering data for proper wire and fuse (breaker) size. Use of extension cords are prohibited.

ELECTRICAL DATA						
Model Numbers	Voltage	Comp. R.L.A.	Comp. L.P.A.	Blower F.L.A.	Fan F.L.A.	Cooling F.L.A.
702-07	220	2.5	12.3	.28	.42	3.20
702-09	220	3.3	16.0	.28	.42	4.60
702-12	220	4.8	30.8	.35	.45	5.60
702-15	220	6.7	40.0	.35	.45	7.50

NOTE: The above based on 80°F DB/67°F WB Indoor Air — 95°F DB/75°F WB Outdoor Air — High speed fan — ARI STD 310.

OPERATION

HEAT — Adjust thermostat knob clockwise to coolest setting and press HEAT button. Roomside blower will start immediately on high speed. Turn thermostat knob counterclockwise to warmest setting. Heating module will now operate and discharge air will be warm.

LOW COOL — Adjust thermostat knob counter-clockwise to the warmest setting. Press **LOW COOL** button. Roomside blowers will run at **LOW** speed. Turn thermostat knob clockwise to coolest setting. Compressor and condenser motor will now operate and discharge air will be cooler.

HIGH COOL — With compressor and condenser motor running, press **HIGH COOL** button. Roomside blower speed will increase.

VENT (Motorized) — Press **VENT** button. Compressor and condenser motor will stop. Roomside blower will run at low speed. The motorized damper will open and provide outside air for ventilation.

VENT (Manual) — Same as above except damper position must be manually set. **NOTE:** Motorized fresh air damper will operate only when the concealed damper override switch is set to the open position. Damper switch (for motorized damper only) is located behind control button panel.

OFF — Press **OFF** button. All system operations will stop.

ELECTRICAL OPERATING SEQUENCE 702 SERIES 07 AND 12

Referring to wiring diagrams for system switch positions.

VENT (Motorized)

L2-F All circuits completed through **F** to **L2**. Closed for all modes of operation.

L1-C Circuit to evaporator motor (low speed).

L1-H Damper motor energized when damper override switch contacts closed (**T1-T2**).

LOW-COOL

L1-A Compressor and condenser motor energized when thermostat closed (**1-2**) on demand for cooling.

L1-C Evaporator motor energized (low speed).

L1-H Same as **VENT** operation.

HI-COOL

L1-A Same as **LO-COOL** operation.

L1-B Evaporator motor energized (medium speed).

L1-H Same as **VENT** operation.

HEAT (Electric Heat) (See Figure 10)

L1-B Same as **HI-COOL** operation.

L1-D Heater element energized when thermostat closes (**2-3**) on demand for heat.

L1-H Same as **VENT** operation.

HEAT (Hydronic - Hot Water) (See Figure 11)

L1-G Valve motor energized closed. No flow through hydronic coil.

L1-B Same as **HI-COOL** operation.

L1-D Valve relay energized when thermostat closes on demand for heat. Valve relay contacts (**4-5**) open, deenergizing valve motor, allowing hot water to flow through hydronic coil.

L1-H Same as **VENT** operation.

HEAT (Hydronic - Steam) (See Figure 12)

L1-B Same as **HI-COOL** operation.

L1-D Valve motor energized when thermostat closes (**2-3**) on a demand for heat. Valve motor opens, allowing steam to flow through hydronic coil.

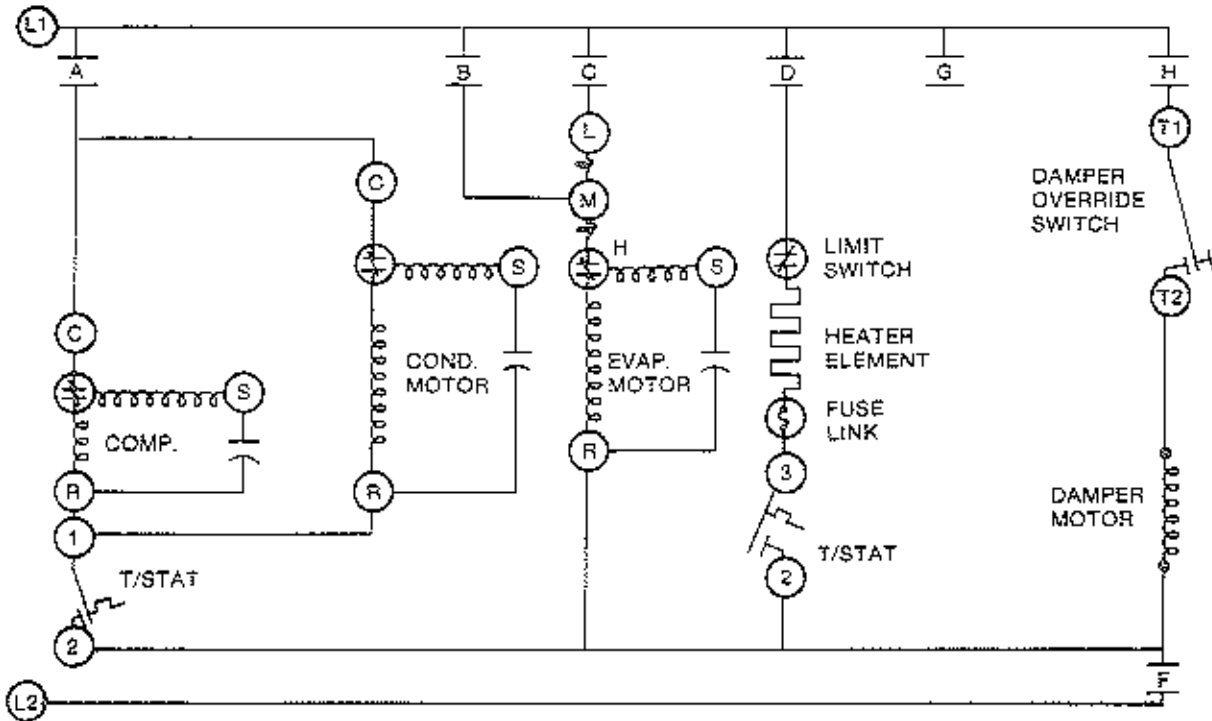
L1-H Same as **VENT** operation.

SERVICE

CHARGING

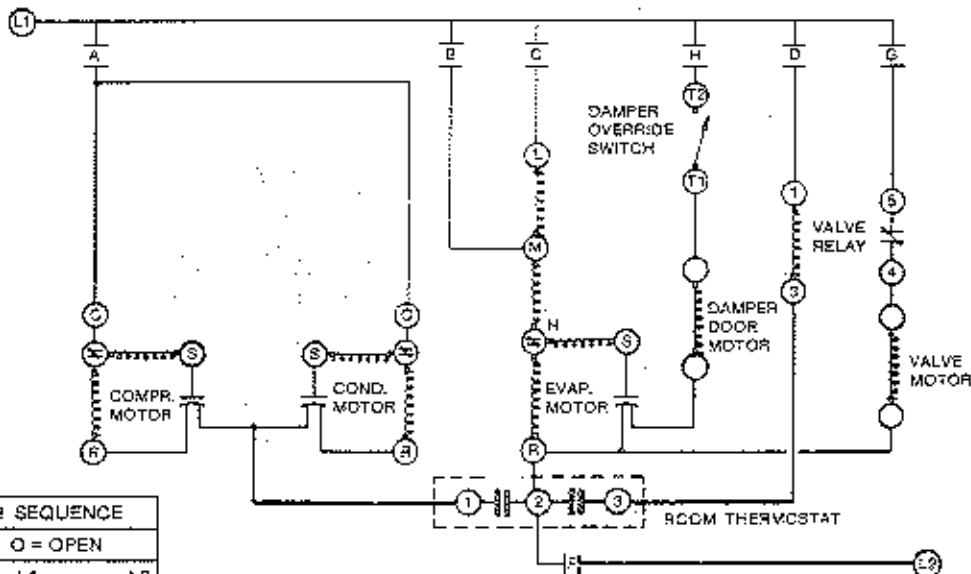
To check system performance, attach ammeter to common leg of compressor. Compare current draw to **RLA** (Rated Load Amps @ **ARI** conditions) on unit nameplate or in unit specification sheet. Current will vary with indoor and outdoor air temperatures and air flow across the evaporator and condenser coil. Note condition of coils and filter prior to system check.

FIGURE 10 WIRING SCHEMATIC — 702 SERIES WITH ELECTRIC HEAT AND MOTORIZED DAMPER (702-07 — 702-12)



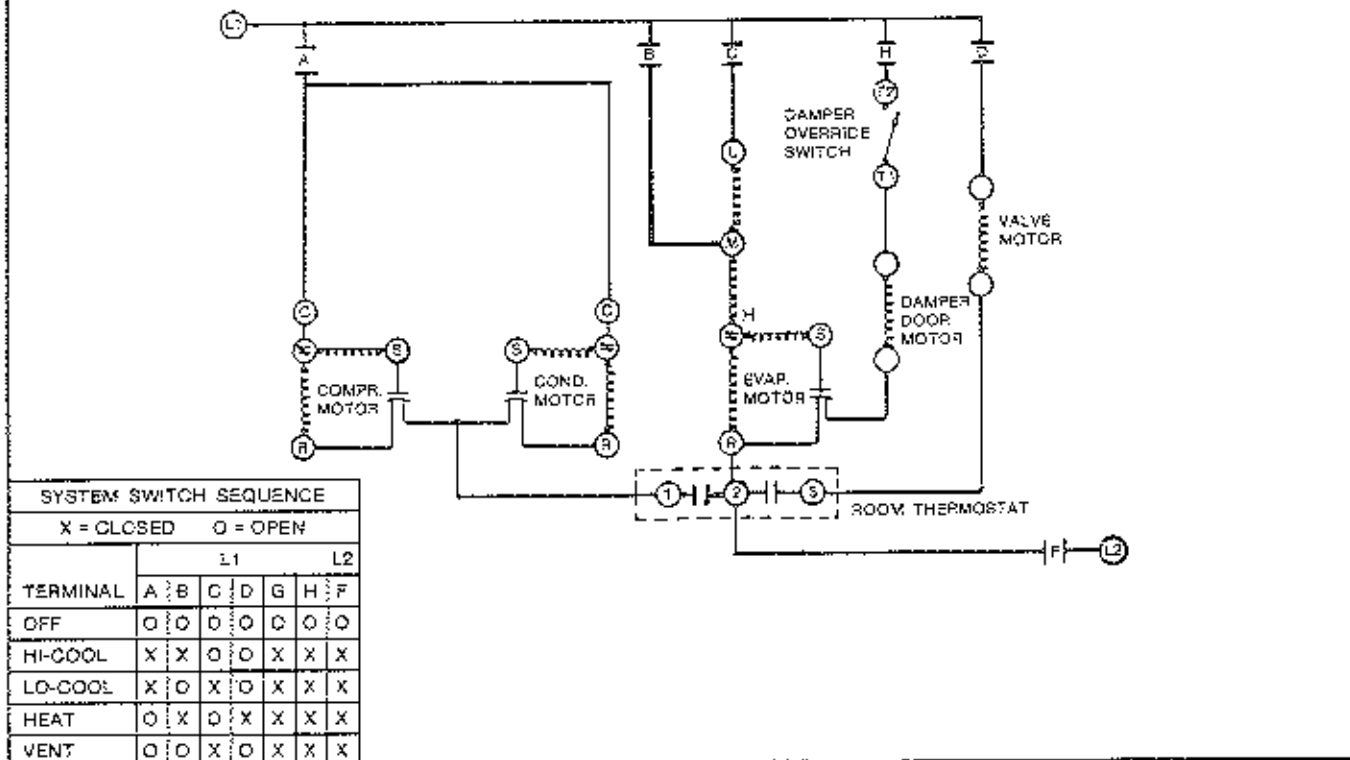
NOTE: IN HEATING MODE THERMOSTAT CONTACTS 2 & 3 ARE CLOSED.
IN COOLING MODE THERMOSTAT CONTACTS 2 & 1 ARE CLOSED.

FIGURE 11 WIRING SCHEMATIC — 702 SERIES WITH MANUAL CHANGEOVER, HOT WATER, AND MOTORIZED DAMPER (702-07 — 702-12) (220 V.)



SYSTEM SWITCH SEQUENCE								
		X = CLOSED O = OPEN						
		L1		L2				
TERMINAL		A	B	C	D	G	H	F
OFF		O	O	O	O	O	O	O
HI-COOL		X	X	O	O	X	X	X
LO-COOL		X	O	X	O	X	X	X
HEAT		O	X	O	X	X	X	X
VENT		O	O	X	O	X	X	X

FIGURE 12 WIRING SCHEMATIC — 702 SERIES WITH MANUAL CHANGEOVER, STEAM HEAT, AND MOTORIZED DAMPER (702-07 — 702-12) (220 V.)



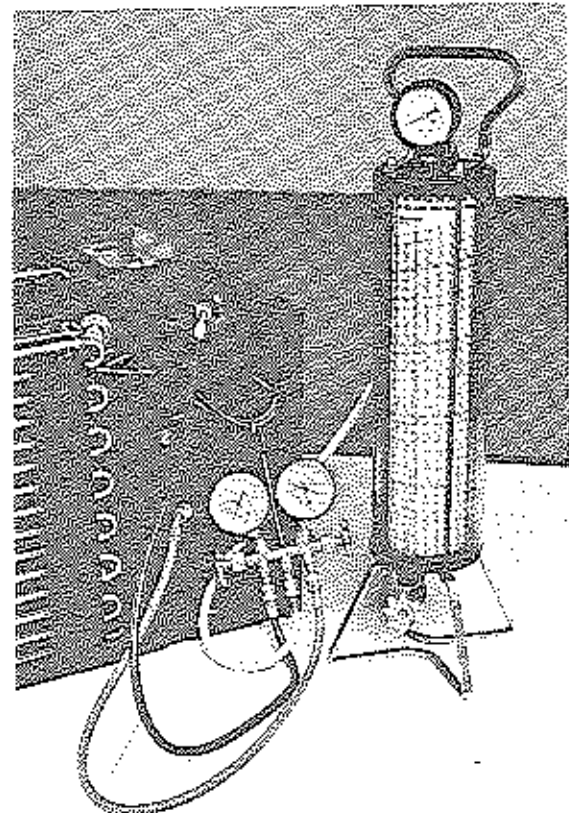
In a case where the complaint is "lack of cooling" provided the unit is sized and installed properly, the unit may be low on charge, an indication of a possible leak. The current draw would also be low. **Do not** use the compressor shell "touch test" to determine a low charge or faulty system.

If a low charge is suspected, leak test the refrigerant circuit prior to venting charge to determine the location of the leak. Vent refrigerant via compressor process tube. Using caution, work tubing cutter back and forth to create small opening. **Do not** cut the tubing completely around until all refrigerant is vented. Repair leak, braze access fittings on process tubing, leak test and evacuate unit to 500 microns. Weigh in nameplate refrigerant (R-22) charge using a dial-a-charge. Accurate charging is critical for performance and reliability. (See Figures 13 and 13A.)

FIGURE 13A

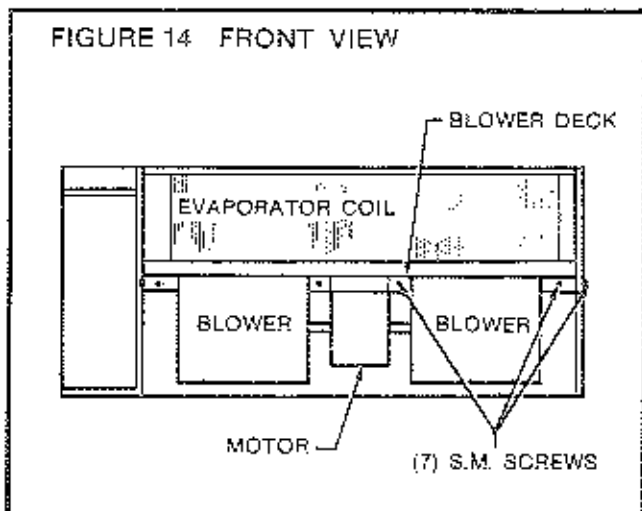
CHARGE R-22	
MODEL NO.	OUNCES
702-07	22.0
702-09	27.0
702-12	22.5
702-15	32.0

FIGURE 13



ELECTRIC HEATER REPLACEMENT

Lift and remove front panel. Remove chassis panel (4 screws), entering air thermostat bulb, heater and indoor fan motor wires from control box, blower deck (2 screws right side, 4 screws back side, and 1 screw left side). (See Figure 14.) Remove wires from heater and screws (2) from heater mounting bracket.



EVAPORATOR MOTOR REPLACEMENT

Disconnect evaporator motor wires from control box. Remove individual blower covers (2 screws on each) and motor support clips (2) and slide out blower motor and wheels. Remove set screws from blower wheels. When installing blower wheels on shaft of new motor, do not tighten set screws until wheels are centered in blower assembly. Install motor support clips and reconnect evaporator motor wires.

SLINGER RING ADJUSTMENT

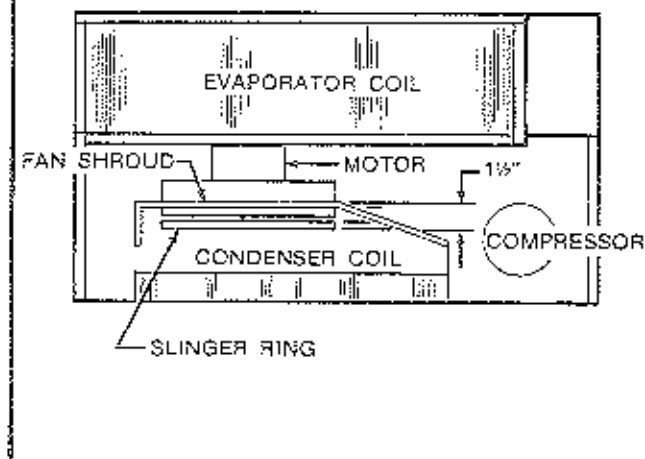
If outdoor fan motor is replaced, the fan/slinger ring should be positioned on the shaft of the new outdoor fan motor a distance of 1½ inches from the outside edge of the fan shroud to outside edge of the slinger ring. (See Figure 15.)

NOTE: The permagum under the fan shroud prevents the condensate from being blown out of base pan and must be replaced if it is removed when servicing the unit.

HYDRONIC COIL VALVE REPLACEMENT

Remove front panel and close supply and return valves for hydronic coil. Remove male connector from female connector in control module. Loosen flare nuts (2) and remove valve.

FIGURE 15 TOP VIEW



MANUAL OPERATION OF HYDRONIC COIL VALVE

During a power failure, the hot water and steam coils can be used as convectors by setting the lever on the valve to the ON position. This will open the valve and allow the residual heat in the water to pass through the hydronic coil.

MAINTENANCE CHECK LIST

1. Oiling at start-up is NOT recommended. However, to increase the life of the motor, lubricate motors once a year with a few drops of #20 SAE oil in each oiler tube. Be sure to replace oiler tube caps.
2. Inspect and clean return air filter at least once a month or as often as necessary, depending on specific job conditions.
3. Inspect indoor and outdoor coil and condensate drain once a year and clean if necessary. Some applications may require cleaning more often than once a year depending on the specific application. The chassis should be removed to an authorized work station if it is necessary to clean outdoor coil.
4. Check for loose electrical connections and electrical component operation once a year. Be sure power is off when checking electrical connections.

Friedrich

Climate Master[®]

Friedrich Air Conditioning & Refrigeration Co.
International Division
4200 N. Pan Am Expressway
Post Office Box 1540
San Antonio, Texas 78295 — U.S.A.
Telephone: 512/225-2000
Telex: WLF 98-368-11
Cable: FLOCATINA/R