

- NOTES:
1. Compressor and Blower Motor thermally protected internally.
 2. All wiring to the unit must comply with NEC and local codes low voltage wiring shall be Class 2 or equivalent.
 3. Transformer wiring is voltage sensitive. Use the layout corresponding to the unit voltage. For 208/230 volt units, the factory default is 208V. For 308/420V operation the factory default is 380V.
 4. FPI provides low temperature protection for WATER. When using ANTI-FREEZE solutions, cut JW3 jumper.
 5. Typical heat pump thermostat wiring shown. Refer to thermostat IOM for wiring to the unit. T-Stat wiring must be "Class 1" and voltage rating equal to or greater than unit supply voltage.

6. 24V Alarm signal shown. For Dry Alarm contact between AL1 & AL2, cut JW1 for CXM/DXM Gen2 or JW4 DXM.
 7. Transformer Secondary Ground via CXM/DXM board standoffs and screws to Control Box.
 8. Blower motor is factor wired for medium & high speeds. For any other combination of speeds, at the motor attach the black wire to the higher of the two desired speed taps, and the blue wire to the lower of the two desired speed taps.
 9. AQUA STAT is supplied with unit and must be wired in series with the hot leg to the pump. Aqua stat is rated for voltage up to 277V.
- MPC1. Factory cut JW1 (CXM) or JW4 (DXM) jumper. Dry Contact will be available between AL1 and AL2.
- MPC2. Refer to MPC Installation application, and Operation Manual For Control Wiring to the unit.
- MPC3. ASW sensors are not required on Water-Water application. ASW06-ASW08 (Water-Air Only) move jumper to LSTAT, ASW13-ASW15 move jumper to Rnet.

MWV1. Wire from "Y1" on TSTAT/MPC/LON to "Y" on control board when MWV is not used.

LEGEND

- Factory Low voltage Wiring
- Factory Line Voltage Wiring
- Field Low voltage Wiring
- Field Line voltage Wiring
- Printed Circuit Trace
- Optional Wiring
- Optional Block
- Capacitor
- Circuit Breaker
- Condensate Pan
- Ground
- High Pressure Switch
- LED
- Low Pressure Switch
- Mate-N-Lock
- Multi Splice Connector
- Optional
 - Relay contacts - N.C.
 - Relay contacts - N.O.
- Relay / Contactor Coil
- Solenoid Coil
- Splice Cap
- Temperature Switch
- Thermistor
- Wire Nut

- AL Alarm Relay Contacts
- BM Blower Motor
- BMC Blower Motor Capacitor
- BR Blower Relay
- CAP Capacitor
- CB Circuit Breaker
- CC Compressor Contactor
- CO Condensate Overflow Sensor
- CR Compressor Relay
- CTB Common Terminal Block
- CS Current Sensor
- DHW Domestic Hot Water
- DM Damper Motor
- DTS Discharge Temperature Switch
- ES End Switch
- EWTS Entering Water Temp Sensor
- FPI Sensor, low temp protection, water coil
- FP2 Sensor, low temp protection, air coil
- FSS Fan Speed Switch
- HP High Pressure Switch
- HPWS High Pressure Water Switch
- HR Heating Relay
- JW Jumper Wire
- LAT Leaving Air Temperature
- LOC Loss of Change Pressure Switch
- LOR Lock Out Relay
- LWTS Leaving Water Temp Sensor
- MOD Modulating Water Valve
- MS Manual Starter
- MSC Multi Splice Connector
- MVV Motorized Water Valve
- PB Power Terminal Block
- PDB Power Distribution Block
- POT Potentiometer
- P1 Field Wiring Terminal Block
- RAS Return Air Sensor
- RVS Reversing Valve Solenoid
- SAC Start Assist Capacitor
- TB Terminal Block
- TRANS Transformer
- TS Terminal Strip
- UMT Unit Mounted Thermostat

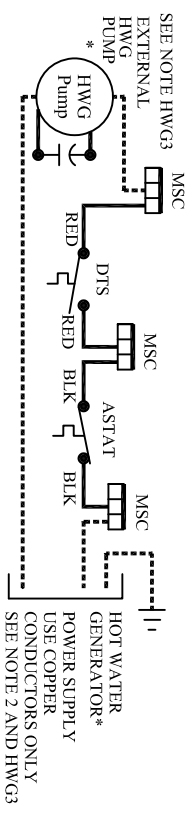

POLARITY SENSITIVE
DDC COMM NETWORK

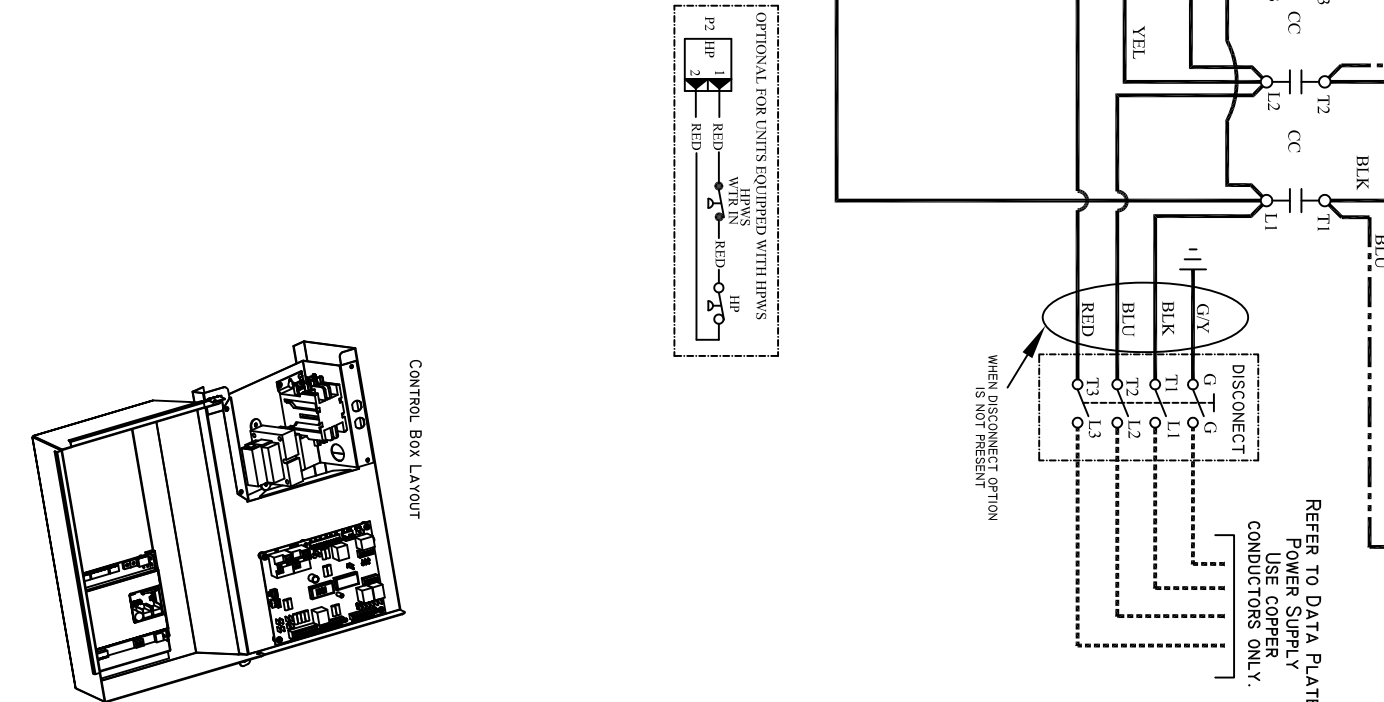
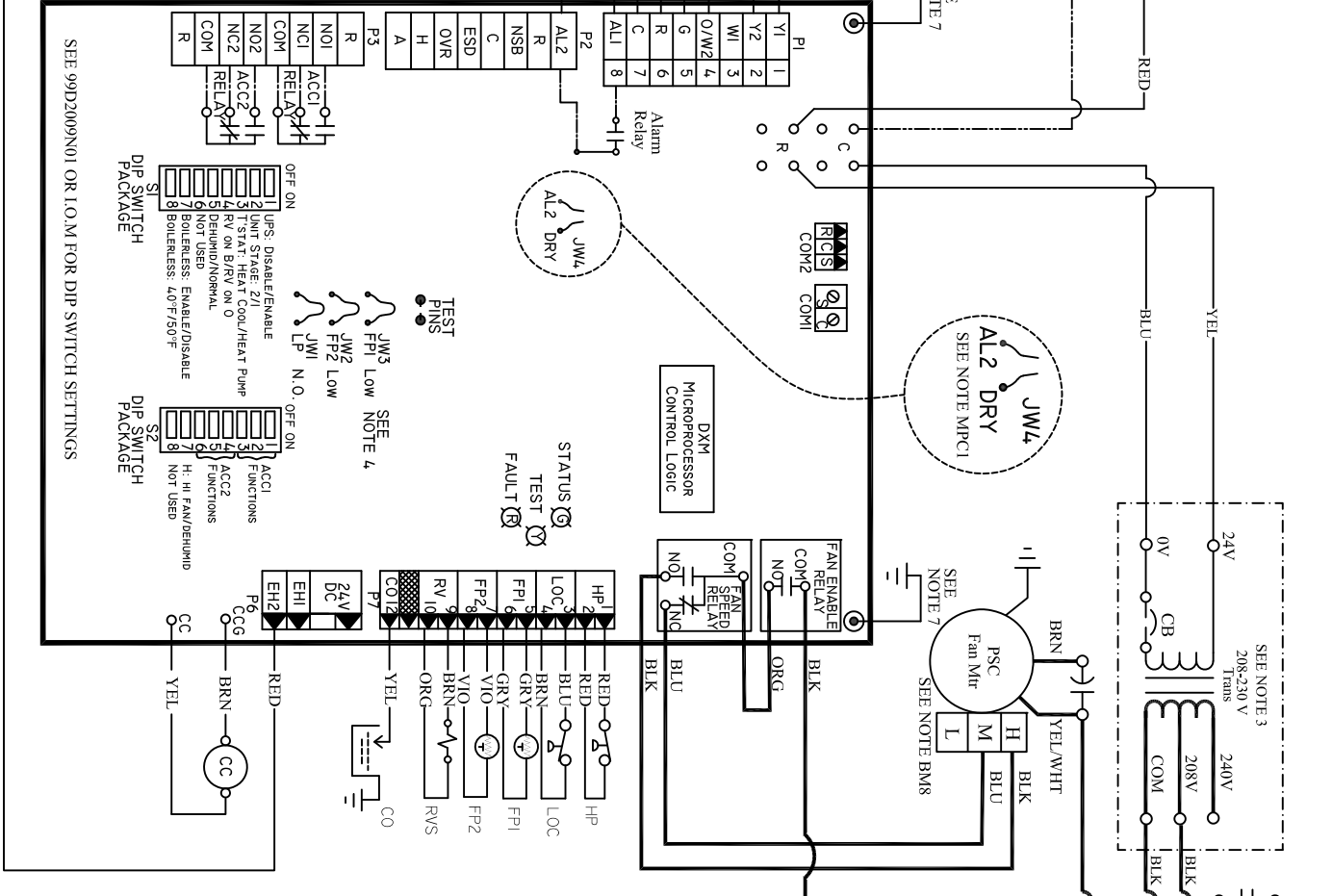
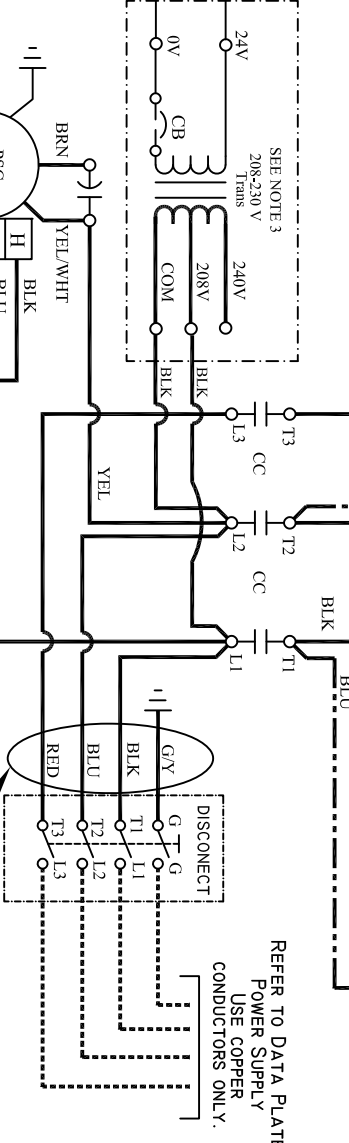
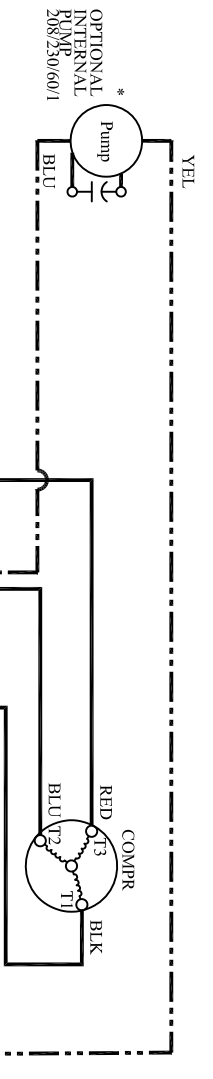
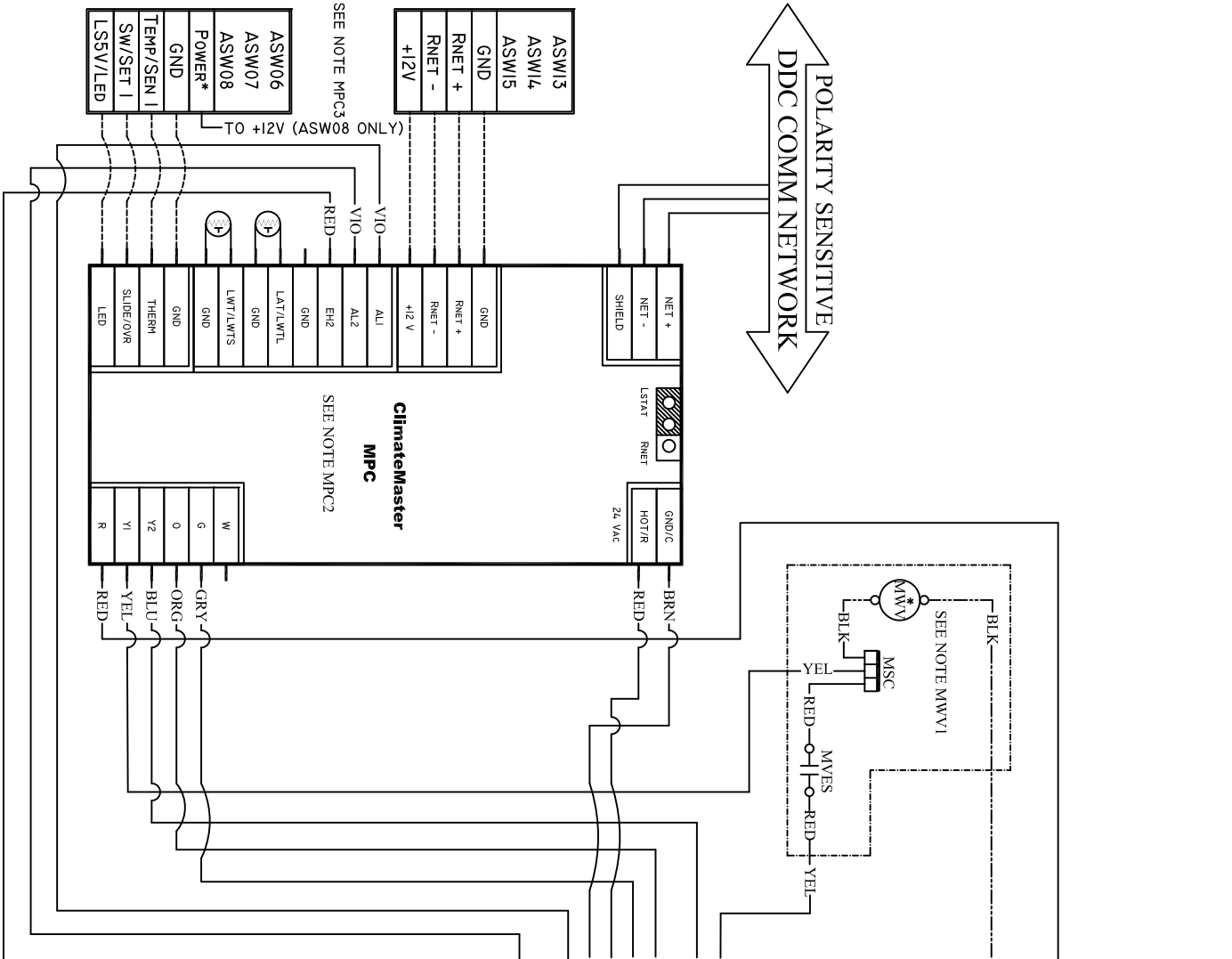

SEE 99D2009N01 OR I.O.M FOR DIP SWITCH SETTINGS

