

TABLE OF CONTENTS

	Page
General Information	3
Inspection	3
Introduction	3
Storage	3
Unit Protection	3
Pre-Installation	3
Location and Access	4
Installation	4
Installation of Supply and Return Piping	4
Condensate Piping	5
Sound Attenuation for Large Commercial Units	6
Electrical Wiring	6
Wall Mounted Thermostat Installation	6
Operating Limits	7
Start-Up Preparation	8
System Checkout	9
Unit Start-Up	10
Maintenance	11

GENERAL INFORMATION

Inspection

Upon receipt of shipment at the job site, carefully check the shipment against the bill of lading. Make sure all units have been received. Inspect the carton or crating of each Large Commercial Unit (LCU) and inspect each unit for damage. Assure that the carrier makes proper notation of any shortages or damage on all copies of the freight bill and that he/she completes a Carrier Inspection Report. Concealed damage not discovered during unloading must be reported to the carrier within 15 days of receipt of shipment. **NOTE: It is the responsibility of the purchaser to file all necessary claims with the carrier. Notify the ClimateMaster Traffic Department of all damage within fifteen (15) days of shipment.**

Introduction

This Installation, Operation and Maintenance manual (IOM) is for ClimateMaster Large Commercial Water Source Heat Pump Systems (LCU).

ClimateMaster Large Commercial Units are typically installed in a floor level closet or in a small mechanical room. The installation site chosen for these units must allow adequate clearance for maintenance and servicing of the unit.

Storage

⚠ CAUTION

DO NOT store or install Large Commercial Units in corrosive environments or in locations subject to temperature or humidity extremes (e.g., attics, garages, rooftops, etc.). Corrosive conditions and high temperature or humidity can significantly reduce performance, reliability, and service life. Always move units in an upright position. Tilting units on their sides may cause equipment damage.

Upon the arrival of equipment at the job site, immediately store units in their shipping cartons in a clean, dry area. **Store units in an upright position at all times.** Stack unit model numbers 080 through 120 no more than 2 units high. Do not stack units larger than 120. **DO NOT remove equipment from shipping cartons until equipment is required for installation.**

Unit Protection

Cover Large Commercial Units on the job site with either shipping cartons, vinyl film, or an equivalent protective covering. Cap the open ends of pipes stored on the job site. In areas where painting, plastering, or the spraying of fireproof material has not been completed, all due

precautions must be taken to avoid physical damage to the units and contamination by foreign material. Physical damage and contamination may prevent proper start-up and may result in costly equipment clean-up.

Examine all pipes, fittings, and valves before installing any of the system components. Remove any dirt found on these components.

Pre-Installation

Installation, Operation and Maintenance (IOM) instructions are provided with each unit. Before unit start-up, read all manuals and become familiar with the unit and its operation. Thoroughly check out the system before operation.

Prepare Large Commercial Units for installation as follows:

1. Compare the electrical data on the unit nameplate with ordering and shipping information to verify that the correct unit has been shipped.
2. Keep the unit covered with the shipping carton until installation is complete and all plastering, painting, etc. is finished.
3. Verify that refrigerant tubing is free of kinks or dents, and that it does not touch other unit components.
4. Inspect all electrical connections. Connections must be clean and tight at the terminals.

⚠ WARNING

To avoid equipment damage, DO NOT use these units as a source of heating or cooling during the construction process. The mechanical components and filters used in these units will quickly become clogged with construction dirt and debris which may cause system damage.

To avoid the release of refrigerant into the atmosphere, the refrigerant circuit of this unit MUST only be serviced by technicians which meet local, state and federal proficiency requirements.

All refrigerant discharged from this unit MUST be recovered without exception. Technicians MUST follow industry accepted guidelines and all local, state and federal statutes for the recovery and disposal of refrigerants.

When a compressor is removed from this unit, system refrigerant circuit oil will remain in the compressor. To avoid leakage of compressor oil, the refrigerant lines of the compressor MUST be sealed after it is removed.

Location and Access

Large Commercial Units are typically installed in a floor level closet or in a small mechanical room. Refer to Figure 1 for an illustration of a typical installation. Install units with adequate clearance to allow maintenance and servicing. Conform to the following guidelines when selecting unit location:

1. Provide adequate clearance for filter replacement and drain pan cleaning. DO NOT block filter access with piping, conduit or other materials. Refer to submittal drawing for Vertical Unit Dimensions.

2. Provide access for fan and fan motor maintenance and for servicing of the compressor and coils without removal of the unit.
3. Provide an unobstructed path to the unit within the closet or mechanical room to enable removal of the unit if necessary.
4. Provide access to water valves and fittings, and screwdriver access to the unit side panels, discharge collar and all electrical connections

Figure 1 - LCU Installation

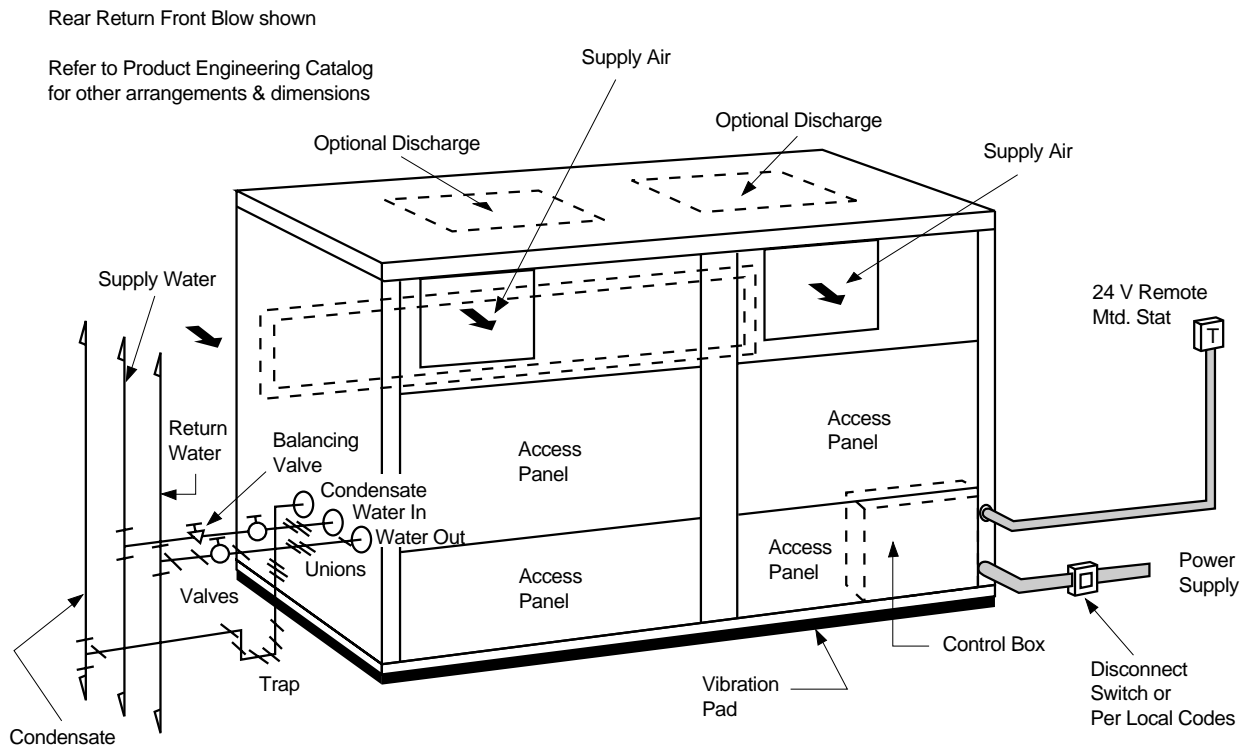

INSTALLATION

The installation of Large Commercial Water Source Heat Pump Units and all associated components, parts and accessories that make up the installation shall be in accordance with the regulations of ALL Authorities having jurisdiction and MUST conform to ALL applicable Codes. It is the responsibility of the Installing Contractor to determine and comply with ALL applicable Codes and Regulations.

Installation of Supply and Return Piping

Follow these piping guidelines:

⚠ CAUTION

Piping must comply with ALL applicable Codes.

1. Install a drain valve at the base of each supply and return riser to facilitate system flushing.
2. Install shut-off/balancing valves and unions at each unit to permit unit removal for servicing.

- Place strainers at the inlet of each system circulating pump.
- Select the proper hose length to allow slack between connection points. Hoses may vary in length by +2% to -4% under pressure.
- Refer to Table 2. DO NOT exceed the minimum bend radius for the hose selected. Exceeding the minimum bend radius may cause the hose to collapse which reduces water flow rate. Install an angle adapter to avoid sharp bends in the hose when the radius falls below the required minimum as shown in Figures 2 and 3.

Figure 2

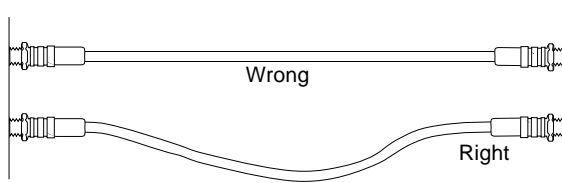

Figure 3

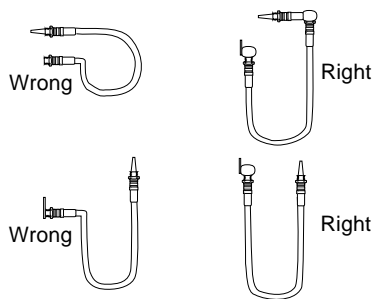

Table 2- Metal Hose Minimum Bend Radii

Hose in Inches	Minimum Bend Radius
1"	5 1/2"
1 1/4"	6 3/4"
1 1/2"	8 3/8"

Insulation is not required on loop water piping except where the piping runs through unheated areas or outside the building. Because loop temperature is normally between 60°F and 90° F, piping will not sweat nor suffer heat loss in normal ambient conditions. For regions outside of the 60° - 90° F range, refer to the job specification to determine if the use of insulation is specified.

Pipe joint compound is not necessary when Teflon threaded tape is pre-applied to hose assemblies or when flared-end connections are used. If pipe joint compound is preferred, use compound only in small amounts on the male pipe threads of the fitting adapters. Prevent sealant from reaching the flared surfaces of the joint.

Maximum allowable torque for brass fittings is 30 foot-pounds. If a torque wrench is not available, tighten

finger-tight plus one quarter turn. Tighten steel fittings as necessary.

Ensure that the trap is filled with water before operating the unit to avoid condensate pan overflow at initial start-up.

⚠ WARNING

DO NOT bend or kink supply lines or hoses.

Optional pressure-rated hose assemblies designed specifically for use with ClimateMaster units are available. Supply and return hoses are fitted with swivel-joint fittings at one end to prevent kinking during installation.

Refer to Figure 4 for an illustration of a Supply/Return Hose Kit. Male adapters secure hose assemblies to the unit and risers. Install hose assemblies properly and check them regularly to avoid system failure, reduced service life and possible damage to surrounding furniture and carpets.

Figure 4- Supply/Return Hose Kit

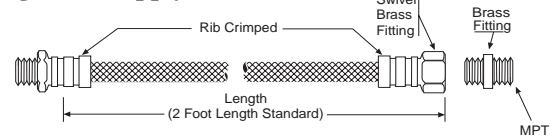

⚠ CAUTION

Corrosive system water requires corrosion-resistant fittings and hoses and may require water treatment.

Condensate Piping

Units are typically installed directly above each other on successive floors with condensate drains located near the units.

Connect the unit condensate drain connection to the building condensate drain with a 1" drain line.

The horizontal run of a condensate hose is usually too short to cause drainage problems, however pitch the horizontal run of the condensate line at least 1 inch for every 10 feet of run in the direction of flow. Avoid low points and unpitched piping since dirt collects in low or level areas and may cause stoppage and overflow.

Install a condensate trap at each unit with the top of the trap positioned below the unit condensate drain connection.

Figure 5 illustrates a typical trap and vent used with LCU Heat Pumps. Design the length of the trap (water-seal) based upon the amount of positive or negative pressure on the drain pan. As a rule, 1" of trap is required for each inch of negative pressure on the unit.

Figure 5 - Condensate Drain

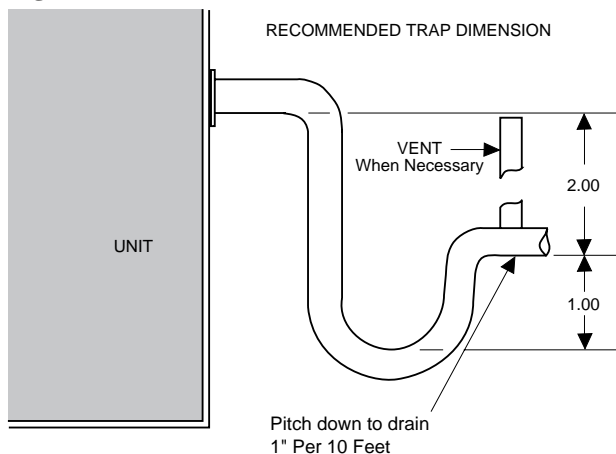

Each unit must be installed with its own individual trap and connection to the condensate line (main) or riser. Provide a means to flush or blow-out the condensate drain line. **DO NOT** install units with a common trap and/or vent.

Install a vent in the condensate line of any application which may allow dirt or air to collect in the line. Always vent when the application requires a long, horizontal run, when some sagging in the condensate line may be anticipated (as in a long line of plastic pipe) or when "double trapping" may occur. Also vent when large units are working against higher external static pressure than other units connected to the same condensate main since this may cause poor drainage for all units on the line. When a vent is installed in the condensate line, it must be located after the trap in the direction of condensate flow.

Sound Attenuation for Large Commercial Units

Sound minimization is achieved by enclosing the unit within a small mechanical room or a closet. Additional measures for sound control include the following:

1. Mount the unit so that the return air inlet is 90° to the return air grille. Refer to Figure 2 on facing page. Install a sound baffle as illustrated to reduce line-of-sight sound transmitted through return air grilles.
2. Mount the unit on a rubber or neoprene isomode pad to minimize vibration transmission to the building structure. Extend the pad beyond all four edges of the unit.

Electrical Wiring

⚠ WARNING ⚠

To avoid possible injury or death due to electrical shock, open the power supply disconnect switch and secure it in an open position during installation.

⚠ CAUTION

Use only copper conductors for field installed electrical wiring. Unit terminals are not designed to accept other types of conductors.

All field installed wiring, including electrical ground, must comply with the National Electrical Code (NEC) as well as all applicable local codes. In addition, all field wiring must conform to Class II temperature limitations described in the NEC.

Refer to the unit name plate for fuse sizes and a schematic of the field connections which must be made by the installing (or electrical) contractor.

Consult the unit wiring diagram located on the inside of the compressor access panel to ensure proper electrical hookup.

Units rated 208-230 volts that have a 24 volt transformer must have the transformer connection modified if the actual power supply is 230 volts. Refer to the unit wiring diagram for details of this procedure.

All final electrical connections must be made with a length of flexible conduit to minimize vibration and sound transmission to the building.

Wall Mounted Thermostat Installation

When the unit has a CXM Series controller, do not use a heat/cool pump thermostat. Use a thermostat with Y, G, O, and W outputs. Refer to unit wiring diagram and CXM Series AOM for additional information.

Vendor installation instructions and additional installation information is shipped with each thermostat.

⚠ CAUTION

Maintain zone integrity to assure accurate and efficient operational control of units or groups of units. Without adequate zone control, adjacent units may operate in heating and cooling mode simultaneously.

All wiring must comply with all applicable electrical codes including NEC and local codes. Refer to the thermostat submittal to verify actual wiring requirements.

Typical Field Installed Wiring

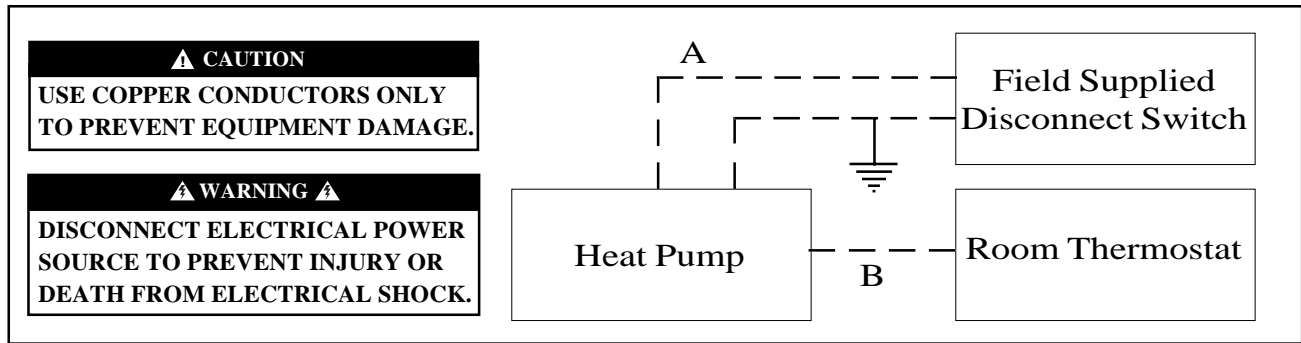

A= Two power wires on single-phase units; three power wires on three-phase units. B= 1 heat /1 cool /Manual or Auto Change-Over remote 24V thermostat. Note: All customer-supplied wiring to be copper only and must conform to NEC and local electrical codes. Wiring shown with dashed lines must be field-supplied and field-installed.

Do not allow the total resistance of all low-voltage wires used to exceed 1 ohm. Resistance in excess of 1 ohm may cause high voltage drop which may result in control malfunction. Refer to the thermostat installation and operation manual to determine recommended heat anticipator settings.

Operating Limits

Environment -This unit is designed for indoor installation ONLY.

Power Supply - A voltage variation of +/- 10% of nameplate utilization voltage is acceptable. Three-phase system imbalance should not be allowed to exceed 2%.

Starting Conditions

Units start and operate in an ambient of 40° F with entering air at 40° F, entering water at 40° F and with both air and water at the stated flow rates of ARI Standard 320-96 rating test for initial winter start-up.

Notes

1. These are not normal or continuous operating conditions. It is assumed that winter start-up is to bring the building space up to occupancy temperatures.
2. Voltage utilization range complies with ARI Standard 110.
3. When using 100% outside air as a source of

ventilation, a 40° F DB minimum and a 78° F WB are acceptable. However, the cabinet may sweat during hot weather.

4. Determination of operating limits is dependent primarily upon 3 factors: 1) return air temperature 2) water temperature and 3) ambient temperature. When any one of these factors is at minimum or maximum levels, the other two factors should be at normal levels to ensure proper unit operation.
5. Extreme variations in temperature and humidity, and corrosive water or air will adversely affect unit performance, reliability and service life.

Operating Limits

Air Limits	Cooling	Heating
Min. Ambient Air	40° F	40° F
Rated Ambient Air	80° F	70° F
Max. Ambient Air	100° F	85° F
Min. Entering Air DB/WB	70/61° F	40° F
Rated Entering Air DB/WB	80/67° F	70° F
Max Entering Air DB/WB	95/76° F	80° F
Water Limits		
Min. Entering Water	40° F	40° F
Normal Entering Water	85° F	70° F
Max. Entering Water	110° F	90° F

START-UP PREPARATION

System Cleaning and Flushing

Cleaning and flushing the unit is the single most important step to ensure proper start-up and continued efficient operation of the system.

Follow the instructions below to properly clean and flush the system:

⚠ WARNING ⚠

To prevent injury or death due to electrical shock or contact with moving parts, open unit disconnect before servicing unit.

1. Verify that electrical power to the units is disconnected.
2. Install the system with the supply hose connected directly to the return riser valve. Use a single length of flexible hose.
3. Open all air vents. Fill the system with water. DO NOT allow system to overflow. Bleed all air from the system. Check the system for leaks and repair appropriately.
4. Verify that all strainers are in place. Start the pumps and systematically check each vent to ensure that all air is bled from the system.
5. Verify that make-up water is available. Adjust make-up water appropriately to replace the air which was bled from the system. Check and adjust the water/air level in the expansion tank.
6. Set the boiler to raise the loop temperature to approximately 85° F. Open a drain at the lowest

point in the system. Adjust the make-up water replacement rate to equal the rate of bleed.

7. Refill the system and add trisodium phosphate in a proportion of approximately one pound per 150 gallons of water. Reset the boiler to raise the loop temperature to about 100° F.

⚠ CAUTION

To avoid possible damage to piping systems constructed of plastic piping, DO NOT allow loop temperature to exceed 110° F.

Circulate the solution for a minimum of 8 to 24 hours. At the end of this period, shut off the circulating pump and drain the solution. Repeat system cleaning if necessary.

8. When the cleaning process is complete, remove the short-circuited hoses. Re-connect the hoses to the proper supply and return the connections to each of the Large Commercial Units. Refill the system and bleed off all air.
9. Test the system pH with litmus paper. The system water should be slightly alkaline (pH 7.5 to 8.5). Add chemicals as appropriate to maintain acidity levels.

⚠ CAUTION

DO NOT use “Stop-Leak” or any similar chemical agent in this system. Addition of these chemicals to the loop water will foul the system and will inhibit unit operation.

10. When the system is successfully cleaned, flushed, refilled and bled, check the main system panels, safety cutouts, and alarms. Set the controls to properly maintain loop temperatures.

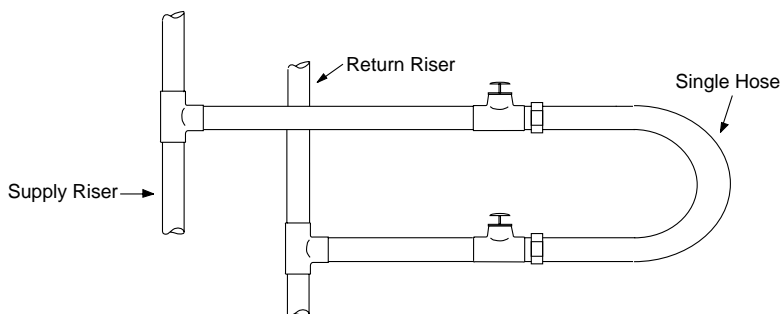

Alternate Connections Method:

Use standard coupling (field-supplied) and hose adapters to join 2 hoses.

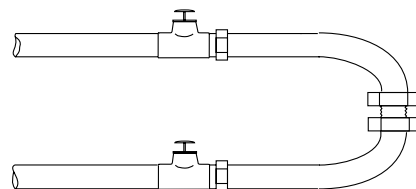

SYSTEM CHECKOUT

When the installation is complete and the system is cleaned and flushed, follow the System Check-out procedure outlined below:

- 1. **Voltage:** Ensure that voltage is within the utilization range specifications of the unit compressor and fan motor.
- 2. **System Water Temperature:** Ensure that it is within an acceptable range to facilitate start-up. (When conducting this check, also verify proper heating and cooling set points.)
- 3. **System Water pH:** Verify system water acidity. (pH = 7.5 or 8.5) Proper pH promotes the longevity of hoses and heat exchangers.
- 4. **System Flushing:** Properly clean and flush system periodically. Ensure that all supply and return hoses are connected end-to-end to facilitate system flushing and prevent fouling of the heat exchanger by system water.

Water used in the system must be of potable quality and clean of dirt, piping slag, and chemical cleaning agents.
- 5. **Closed-Type Cooling Tower or Open Tower with Heat Exchanger:** Check equipment for proper temperature set points and operation.
- 6. **Balanced Water Flow Rate to Heat Pump:** Verify the inlet and outlet water temperatures are recorded as each heat pump unit is started. This check will eliminate nuisance unit trip-outs resulting from water velocities which are either too low or too high; it can also prevent the occurrence of erosive water flow rates.
- 7. **Standby Pump:** Verify that the standby pump is properly installed and in operating condition.
- 8. **System Controls:** To ensure that no catastrophic system failures occur, verify that system controls are functioning and that the sequencing is correct.
- 9. **Freeze Protection for Water System:** Verify that freeze protection is provided for the outdoor portion of the loop water system. Inadequate freeze protection can cause system operating problems.
- 10. **System Water Loop:** Verify that all air is bled from the system. Air in the system impedes unit operation and causes corrosion in the system piping.
- 11. **Unit Filters:** To avoid system damage, ensure that the unit filter is clean.
- 12. **Unit Fans:** Manually rotate fans to assure free rotation. Ensure that fans are properly secured to the fan shaft. Do not lubricate fan motors on start-up since they are lubricated at the factory.
- 13. **System Control Center:** To ensure control of the temperature set-points for operation of the system's heat rejector and boiler, examine the system control and alarm panel for proper installation and operation.
- 14. **Miscellaneous:** Note any questionable aspects of the installation.

CAUTION

To avoid equipment damage, DO NOT leave system filled in a building without heat during the winter unless anti-freeze is added to system water. Condenser coils never fully drain by themselves and will freeze unless winterized with anti-freeze.

UNIT START-UP

Use the procedure outlined below to initiate proper unit start-up:

⚠ WARNING ⚠

When the disconnect switch is closed, high voltage is present in some areas of the electrical panel. Exercise caution when working with energized equipment.

1. Turn all valves to their full open position. Turn on the line power to all heat pump units.

NOTE: The units with scroll compressors are tested for matched rotation of fan motor and scroll compressors. At startup check fan rotation, if fan rotation is correct all scroll compressor will automatically have correct rotation. If fan rotation is incorrect, interchange any two power supply lead connections at the disconnect. Scroll compressors with INCORRECT rotation show following operating characteristics: 1) High sound level 2) High suction pressure 3) Low current draw.

2. Operate each unit in the cooling cycle. Room temperature should be approximately 70° to 75° F DB, and 61° to 65° F WB. Loop water temperature entering the heat pumps should be between 70° F and 110° F.

When the unit is operating in the cooling mode under ARI conditions, the leaving water temperature is approximately 10° F warmer than the entering water temperature at 3 GPM / ton.

- a. Turn the unit thermostat to the cooling position. If the unit has an optional MCO thermostat, set the selector switch to COOL. Both the fan and compressor should run.

For heat pumps with ACO, adjust the cooling set point to a temperature at least 3° F below room temperature.

- b. Check for cool air delivery at the system grille within a few minutes after the unit has begun to operate. List the identification number of any machines that do not function.
- c. Check the elevation and cleanliness of the condensate lines. Dripping may be a sign of a blocked line.

3. Operate each heat pump in the heating cycle immediately after checking cooling cycle operation. A time delay will prevent the compressor from re-starting for approximately 5 minutes.

NOTE: Large Commercial heat pump units are

designed to start heating at a minimum return air temperature of 40° F with normal water flow rate and ambient temperature.

- a. If the unit has an optional MCO thermostat, set the temperature indicator to the highest setting and set the selector switch to HEAT. The fan and the compressor should start.

If the unit has an optional ACO thermostat, set the temperature indicator to the far right setting and set the selector switch to AUTO. The fan and the compressor should start.

- b. Once the unit has begun to run, check for warm air delivery at the unit grille. List the serial number of any machines that do not function.
4. Establish a permanent operating record by logging the unit operating conditions at initial start-up for each unit.
 5. If a unit fails to operate, conduct the following checks:

- a. Check the power supply. It should comply with the electrical specifications described on the unit nameplate.
- b. Look for wiring errors. Check for loose terminal screws where wire connections have been made on both the line and low-voltage terminal boards.
- c. Check for dirty filters. A clogged filter will cause safety cutouts to stop unit operation.
- d. Check the supply and return piping. They must be properly connected to the inlet and outlet connections on the unit.
- e. Check the fan. If the fan fails to operate, verify that the fan wheel turns freely and that it is secured to the shaft. Also verify that the fan operates in both heating and cooling modes, and rotates in the proper direction.
- f. If the checks described above fail to reveal the problem and the unit still will not operate, contact a trained service technician to ensure proper diagnosis and repair of the equipment.

NOTE: Refer to Controller AOM provided with the unit for status light operation and fault codes

MAINTENANCE

Maintenance Procedures

Perform the maintenance procedures outlined below periodically as indicated:

WARNING

To prevent injury or death due to electrical shock or contact with moving parts, open unit disconnect switch before servicing unit.

FILTERS: Inspect filters. Establish a regular maintenance schedule. Replace/clean filter frequently depending upon need.

To remove the filter from a Large Commercial Unit, slide the filter out of its frame located in the return air opening. When re-installing the filter, use the slide-in rails of the filter frame to guide the filter into the proper position. Verify that the airflow arrow found on the top of each filter points toward the unit. Always replace filters with the same size and quantity of filters as removed from the unit.

CAUTION

To avoid fouled machinery and extensive unit clean-up, DO NOT operate units without filters in place. DO NOT use equipment as a temporary heating or cooling source during construction.

CONDENSATE PANS: Check condensate drain pans for algae growth every three (3) months. If algae growth is apparent, consult a water treatment specialist for proper chemical treatment. The application of an algicide every three (3) months will typically eliminate algae problems in most locations.

FAN MOTORS: Lubricate fan motors annually. All ClimateMaster Large Commercial Units are fully lubricated at the factory. DO NOT lubricate during installation. Check all belts and sheaves for wear. Adjust and replace as needed.

Conduct amperage checks annually. Amperage draw should not exceed normal full load or rated load amps by more than 10% of the values noted on the unit nameplate. Maintain a log of amperage values to detect deterioration prior to component failure.

UNIT INSPECTION: Visually inspect the unit annually. Pay special attention to hose assemblies. Repair any leaks and replace deteriorated hoses immediately.

COMPRESSOR: Conduct amperage checks on the compressor annually. Amperage draw should not exceed

normal full load or rated load amps by more than 10% of the values noted on the unit nameplate. Maintain a log of amperage values to detect deterioration prior to component failure.

WARNING

When replacing the compressor contactor or lockout relay in a unit with electromechanical controls, use only ClimateMaster replacement parts. Substitution of other components may result in an inoperative safety circuit and may cause a hazardous condition.

HEAT EXCHANGERS: Clean heat exchangers annually. Inspect heat exchangers regularly and clean more frequently if the unit is located in a “dirty” environment.

NOTE: If the unit must be reset more than twice, check the unit for a dirty filter, abnormal entering water temperature, inadequate or excessive water flow and internal malfunction. If the unit continues to cutout, contact a trained service technician.

Controller and Safety Protection

The microprocessor-based controller monitors and controls unit operation. The controller provides compressor sequencing, high and low pressure monitoring, field selectable water and air coil freeze protection sensing, condensate overflow sensing, over/under voltage monitoring, and unit performance sentinel. The control provides a test mode, short cycle protection, random start-up, a fault LED, fault memory, and intelligent fault retry. Note the controls operation below and refer to the controller AOM provided with each unit for specific controller features, specifications and operations.

Interstage Time Delay On two compressor units, a time delay between stage I and stage 2 can be set with a dip switch on compressor 2 controller.

Pressure Switches Pressure switches are normally closed during normal operating conditions, and open upon fault. The high pressure switch opens at 375 PSIG and automatically closes at 300 PSIG. The low pressure switch opens at 10 PSIG and automatically closes at 33 PSIG. The low pressure switch must be open for 30 continuous seconds to cause a fault.

Freeze Protection Thermistors used for freeze protection, is a NTC (negative temperature coefficient) type. Freeze protection is set at 30 degrees Fahrenheit for water systems. If antifreeze is used, the freeze protection can be set at 10 degrees Fahrenheit by cutting a jumper on the controller.

MAINTENANCE (cont.)

Condensate Overflow The condensate overflow sensor will detect a high water level in the air coil drain pan. A signal will travel from the sensor through the water to a ground source (the air coil). Grounding the condensate overflow signal from the controller causes a fault after 30 continuous seconds.

Over/Under Voltage When the controller senses a voltage over 30Vac or under 19Vac for .5 second the unit will shutdown. When the voltage returns to a value between 19Vac and 30Vac, the controller will automatically reset and restart the unit.

Anti Short Cycle The controller provides 5-minute anti-short cycle protection for the compressor. The controller provides a random start upon power up from 5-80 seconds.

LED The status LED on the controller advises the current status or faults of the controller. The unit performance sentinel will give a warning when the heat pump is operating inefficiently. Refer to the wiring diagram for LED fault codes and unit operating status.

Controller Lockout Controllers can be reset from lockout mode by cycling the thermostat off and on, or cycling the disconnect off and on.

Test Mode Test mode can be entered by momentarily shorting the test pins on the controller. The unit will stay in test mode for 20 minutes.



Part #:69197306



7300 S.W. 44th Street
Oklahoma City, OK 73179
Phone: 405-745-6000
Fax: 405-745-6058
www.climatemaster.com

ClimateMaster works continually to improve its products. As a result, the design and specifications of each product at the time of order may be changed without notice and may not be as described herein. Please contact ClimateMaster's Customer Service Department at 1-405-745-6000 for specific information on the current design and specifications. Statements and other information contained herein are not express warranties and do not form the basis of any bargain between the parties, but are merely ClimateMaster's opinion or commendation of its products.