

SERIES 700
AIR COOLED
THRU-THE-WALL
CONSOLE MODELS

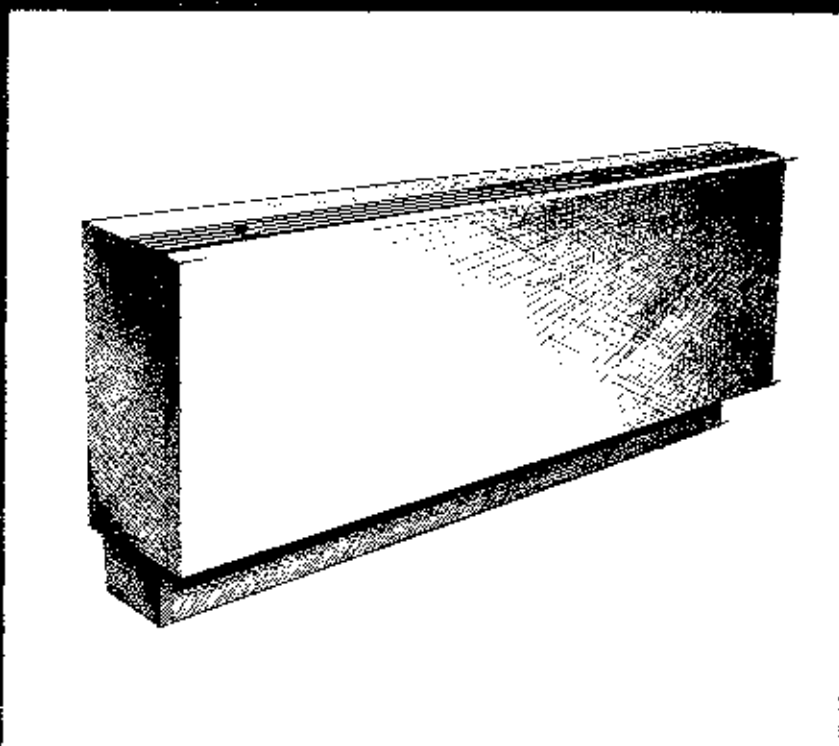

Friedrich[®] Climate
Master
Series

THE ENERGY ECONOMISERS

ENGINEERING DATA

The Climate Master Individualized System.

Thru-the-Wall Heating and Cooling for use with Electric Heat • Steam Heat • Hot Water Heat

A modern air conditioning system for every significant building — Office Buildings, Hotels, Motels, Apartment Houses, Dormitories, Hospitals, Nursing Homes, Schools, Medical Clinics, and Churches.

Climate Master Individualized Control System Advantages

1. Year round control of heating and cooling at the push of a button. Each occupant can control his own comfort.
2. Economy of operation by providing either heating, ventilation or cooling in areas or zones only where it is required — the ability to thermally match the building and its occupants to their required comfort without waste.
3. Economy of installation by properly matching the total zone requirements to an individualized concept. This allows reduced space or provides additional space for more functional purposes — simplifies controls — allows easier handling and installation. Due to simplicity of design and application long term maintenance contracts are usually available at reasonable rates thus reducing in-house maintenance expenses.

4. Economy of maintenance by incorporating fundamental innovations such as complete removal of control modules for repair without removing the chassis or complete front access to control module if repair in place is desired — ease of fan and motor replacement without removing chassis — top and front access panels removable for maintenance of condenser compressor section — minimizes down time.

5. Flexibility with dependability includes a wide range of control options to coordinate the comfort and convenience needs — Manual Changeover, Automatic Changeover, Low Limit Setbacks, Wall Thermostats, Master-Slave Arrangements, Guest Room Control, Emergency Power Controls, and Security Guard.

6. Comfortable noise levels since both room-side and condenser-side fans are slow speed forward curved centrifugal fans. The compressor is double isolated to maximize noise reduction, an essential element in providing total individualized comfort.

7. Flexibility in design and application for use with a wide range of power configurations utilizing in addition to cooling and ventilation variable selections of electric heat, steam heat and hot water heat sections.

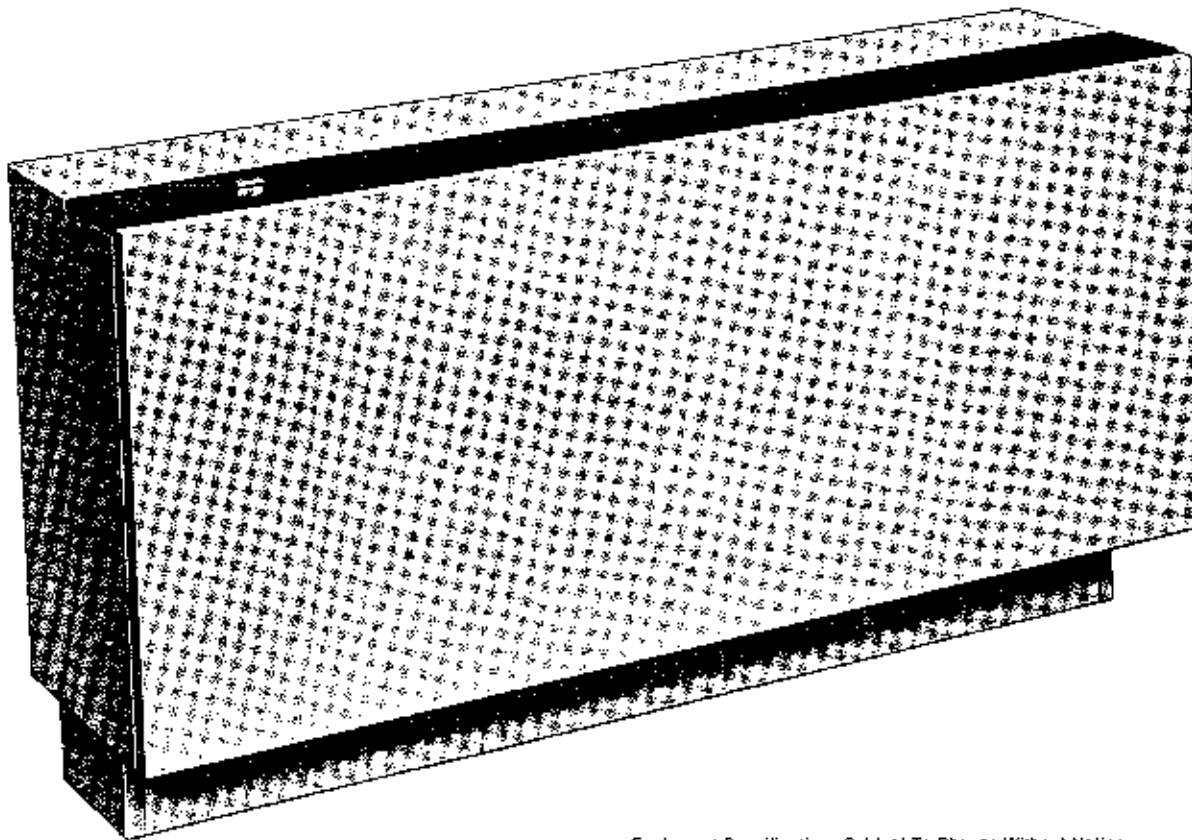

Climate Master

Cooling and Electric and Hydronic Heating Performance Data

COOLING CAPACITIES

MODEL NO.	VOLTAGE	CAPACITY (BTUH)	UNIT FLA	COMPR LRA	TOTAL UNIT WATTS
700-07	208	7,600	6.6	23.0	1260
	230		6.6	23.0	1260
	265		5.5	22.5	1360
700-09	208	9,300	8.7	32.5	1690
	230		8.7	32.5	1690
	265		7.1	33.0	1800
700-12	208	11,300	9.4	37.5	1900
	230		9.4	37.5	1900
	265		7.5	36.0	1930
700-14	208	14,000	14.2	57.0	2830
	230		14.2	57.0	2830
	265		11.7	55.0	2960
700-17	208	16,500	14.5	51.0	2900
	230		14.5	51.0	2900
	265		13.6	55.0	2975

Cooling capacity rating based on ARI standard 310-70 test conditions. See page 4 for correction factors.

STEAM HEATING CAPACITIES

MODEL	BTUH
700-07 & 700-09	22,100
700-12 & 700-14	22,100
700-17	27,000

Based on 65° EA 215° steam 2.3 ft. pressure drop.

HOT WATER HEATING CAPACITIES

MODEL	BTUH
700-07 & 700-09	16,600
700-12 & 700-14	16,600
700-17	19,300

Based on 200° E.W. 65° EA 20° ΔT @ 2GPM .5 ft. pressure drop.

ELECTRIC HEATING CAPACITIES*

MODEL	208V			230V			265 V		
	BTUH	WATTS	AMPS	BTUH	WATTS	AMPS	BTUH	WATTS	AMPS
700-07, 09, 12, 14, 17	9,000	2650	12.7	8,850	2600	11.3	12,950	3800	13.7
	10,900	3200	15.4	11,050	3250	14.1	16,000	4700	17.0
	12,650	3710	17.8	13,300	3900	17.0			
	14,450	4250	20.4	15,500	4550	19.8			

AIR DELIVERY

MODEL	CFM HI	CFM LO	VENTILATION CFM
700-07 700-09	350	320	70
700-12 700-14	350	320	70
700-17	460	400	70

*Note: Fan amps & watts not included.

Cooling Correction Factors

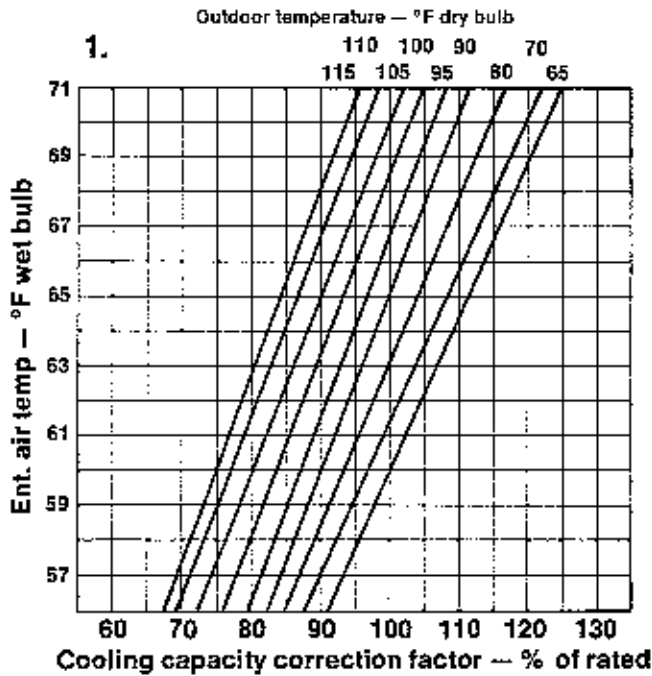

1. Cooling correction factor vs. Return air WB and outdoor DB
2. Ratio of sensible to total heat vs. Return air DB and WB
3. Power input vs. outdoor WB

For estimating cooling capacities at other than standard conditions multiply rated capacity by correction factor determined from outdoor DB and return air DB.

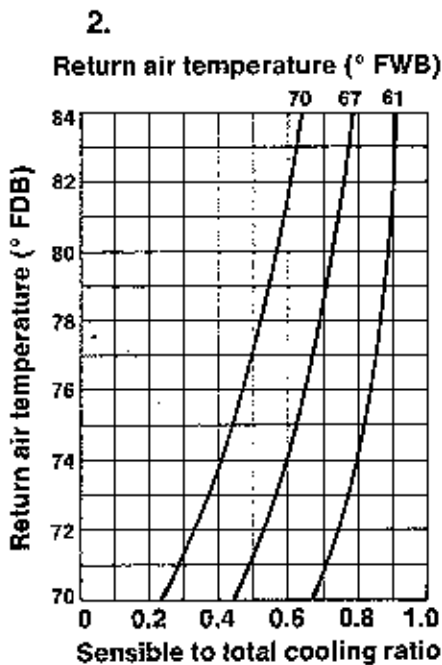

For estimating sensible to total cooling ratio other than standard conditions multiply rated ratio by correction factor determined from return air DB and WB.

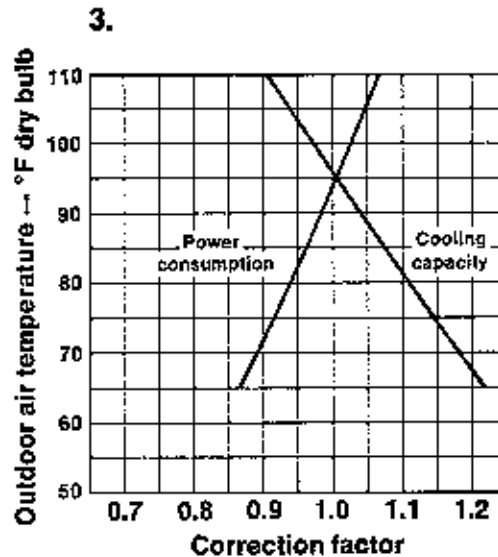

For estimating power consumption at other than standard conditions multiply rated consumption by correction factor determined from outdoor DB.

Heating Correction Factors

4. Hot water flow rates vs. pressure drop
5. Hot water heating capacity as function of return air temperature, flow rate and entering water temperature
6. Steam pressure vs. return air temperature

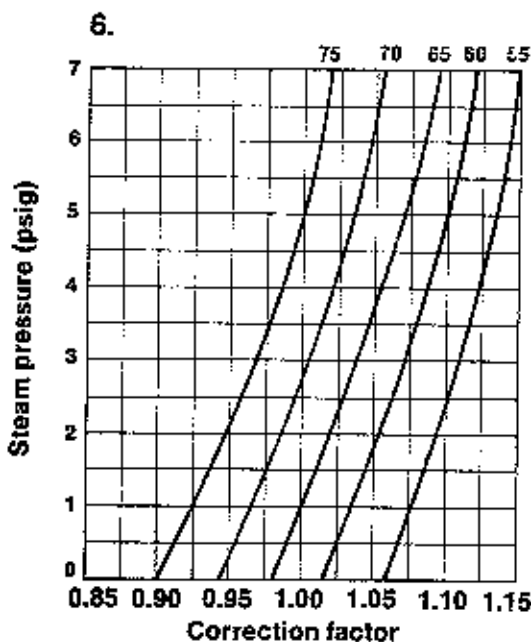
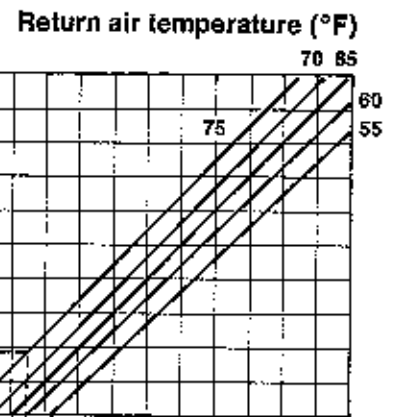
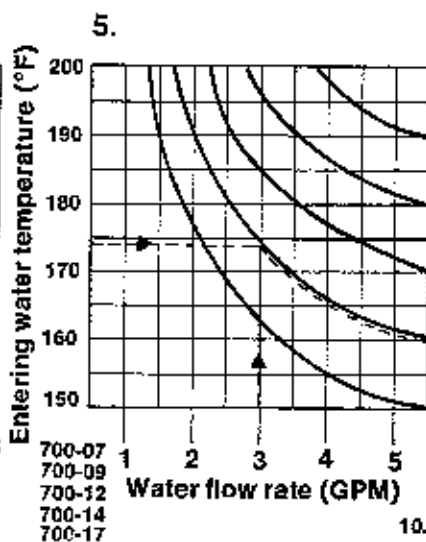
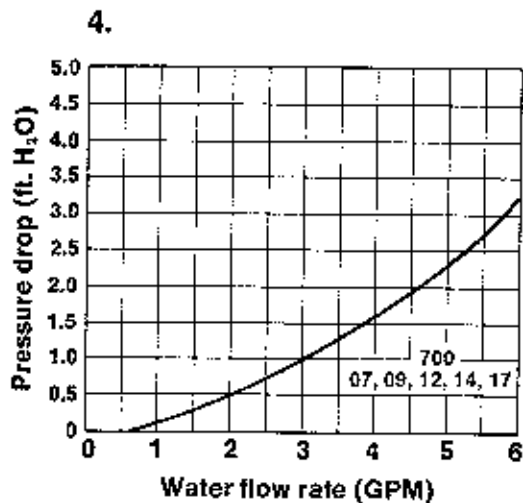

For determining corrected hot water heating capacity as a function of flow rate, entering water temperature and return air temperature.

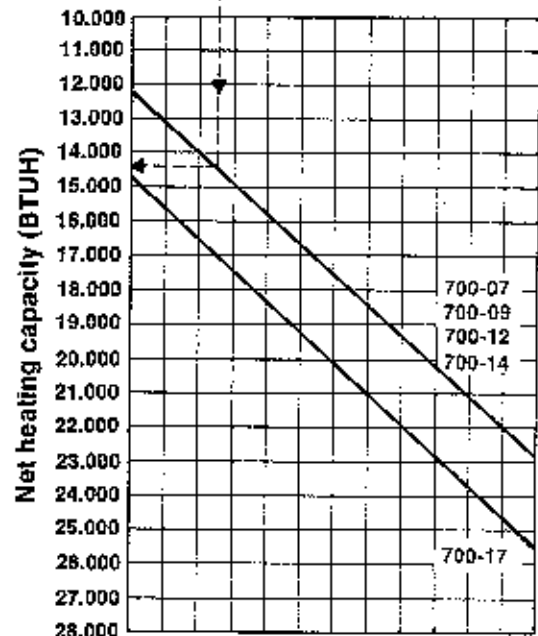

Multiply rated steam capacity by correction factor determined by steam pressure and return air temperature.

• ARI standard 310-70

Equipment Dimensions

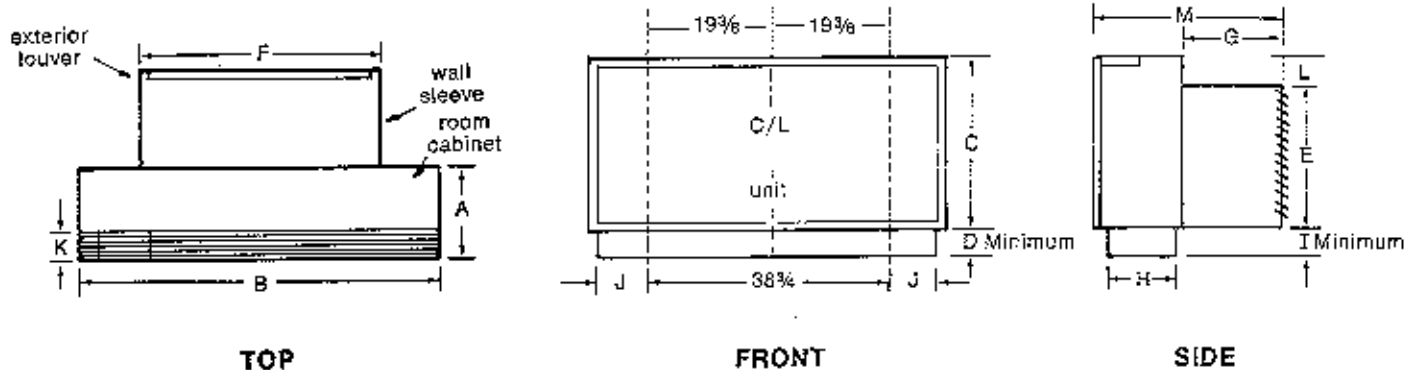

DESCRIPTION		MODEL	
		700-07 700-09 700-12 700-14	700-17
A	Cabinet Depth	11 3/4	17
B	Cabinet Width	48	48
C	Cabinet Height Elec./HW & steam	20/21	23/24
D	Base height (adjustable) Minimum	3	3
E	Wall box height	16	16
F	Wall box width	36 3/4	36 3/4
G	Wall box depth adjustable to 1" increments for varying wall thickness	10 std.	10 std.
H	Base width	6 1/4	11 1/2
I	Wall box height above floor (adjustable) Minimum	3	6
J	Right and Left side piping compartment	3 1/2	3 1/2
K	Discharge Grille depth	5 3/4	5 3/4
L	Elec. Heat/HW or steam heat	4 3/8 / 5 3/8	4 3/8 / 5 3/8
M	Total Minimum Unit Depth	21 3/4	27

Note: Total Cabinet Height equals Dim from bottom of wall opening (I Dim) + Wallbox Height (16") = L' = I + L = 16

Note: Dimensions are indicated from finished floor line. Allow 1/2" to 3/4" for carpeting.

Note: Wall box can be set higher off the floor than shown. If this is done special height kick plates are required.

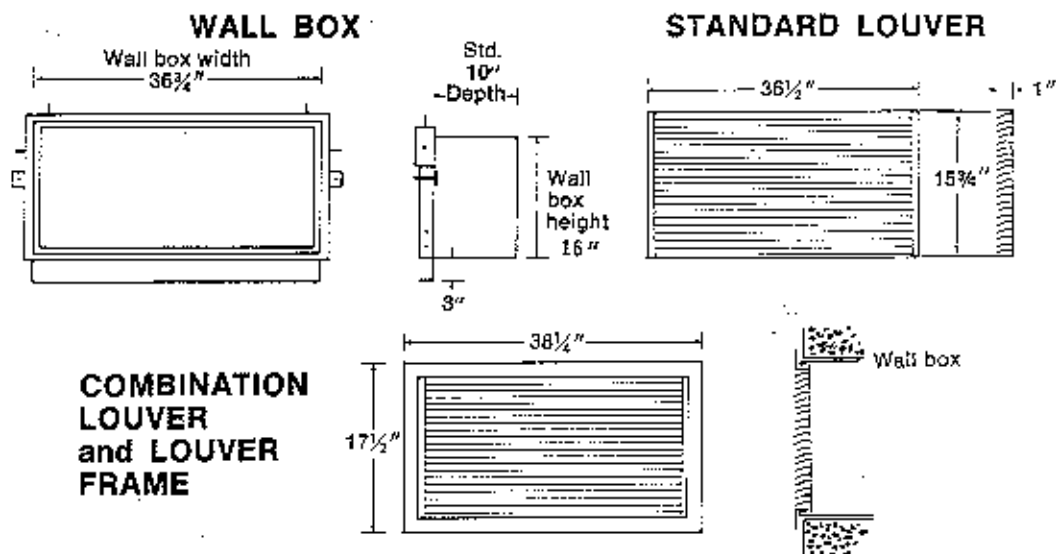

Installation Applications

For new construction and/or existing buildings

Wall Construction standard 10" Depth

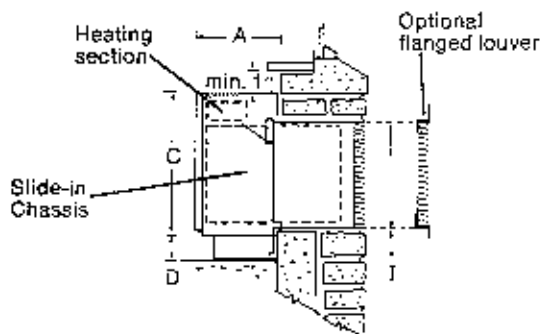

Wall boxes should be parged to masonry and lagged to prevent movement. If the wall construction is 5" to 9" in depth a blocking beneath the box should be considered.

Wall Construction Greater than 10" Depth

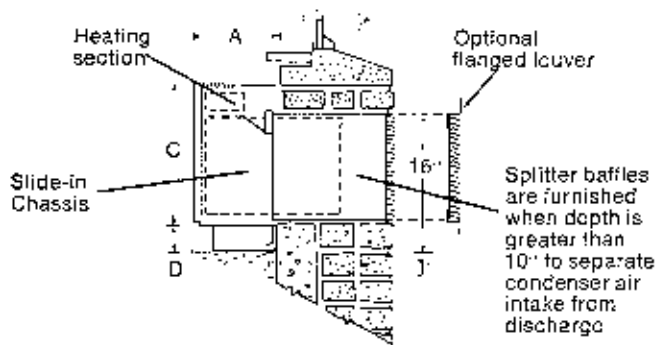

Wall boxes are available in 1" increments 12" through 25". Splitters shipped with wall sleeve.

Wall Construction with panel walls

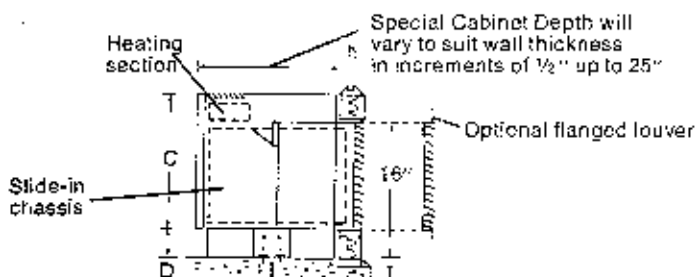

Wall box support legs anchor to floor

Special note:

If flanged louver is used the wall sleeve must be mounted flush with outside wall within 1/8"

Steam

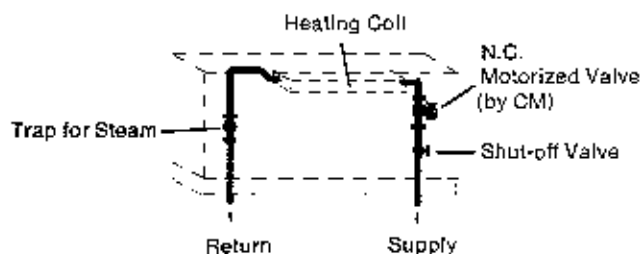

Hot Water

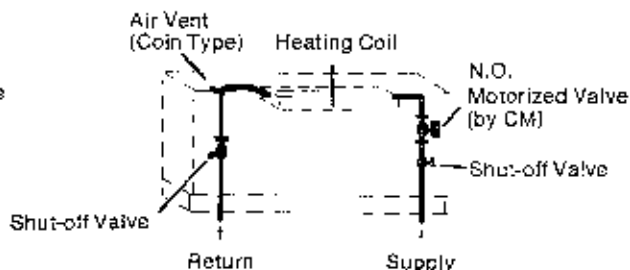

Note: L.H. supply and return or R.H. supply and return also available.

DESIGN AND OPERATIONS

Cooling Chassis

Single package unit includes compressor internally spring-mounted and externally vibration-isolated, with built-in overload protection and capacitor. Direct-Drive Centrifugal Condenser fan with special coating provides positive condensate removal. Plate finned condenser coil and expansion valve operation. Room side blowers are slow two-speed centrifugal fans with built-in overload protection, easily removable. Evaporator coil with condensate pan connected by plastic hose to condenser side. Fresh air filter provides full filtration through motorized F.A. damper.

Heating Sections

Electric

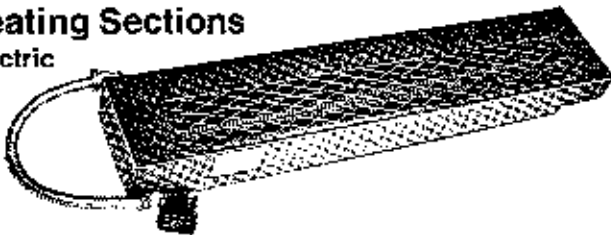

Electric (shown) easily attached to cabinet section low density sheathed elements with overheat protection.

Steam and Hot Water

Steam and Hot Water hydronic heating coil self-contained in frame for mounting to wall sleeve so as not to interfere with removal of cooling chassis. Supply and return connection either at same or opposite ends . . . includes a motorized valve.

Control Modules

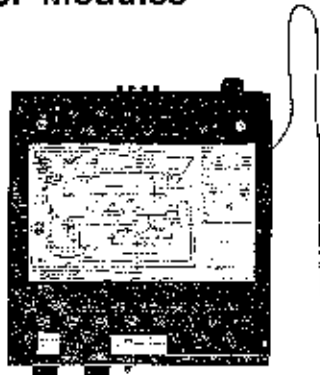

Self-contained removable module (without removing cooling section or heating section) is furnished with manual changeover, automatic changeover, wall thermostat, master-slave, security guard, guest room control, and emergency power options.

(shipped separately)

Cabinet

Constructed of heavy gauge furniture steel with baked enamel finish, available in various colors. Kick plate is adjustable and can be furnished in heights to match sill heights and wall box positions. Discharge grille is extruded aluminum with polished top and shaded interior, with bars set at 15° deflection. Control access door is hinged for easy access and can be furnished with exposed knob or flush. Return air enters unit beneath front panel and through kick plate.

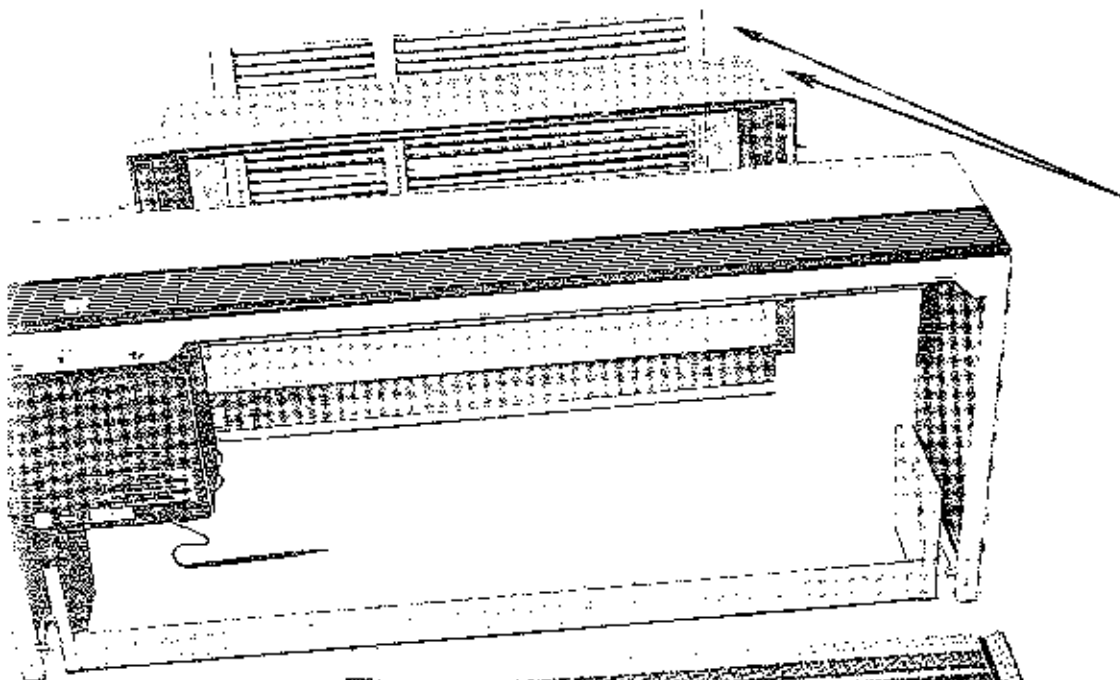

Outdoor Louver

Extruded aluminum with clear anodized finish snaps into wall box from inside. Available in other colors, and can be incorporated with outside flanged frame.

Wall Box

Single piece heavy gauge aluminum with temporary removable weather seal with built-in glides and pitch. Hardware built in for mounting heating section, cabinet and securing chassis gives weather-tight seal.

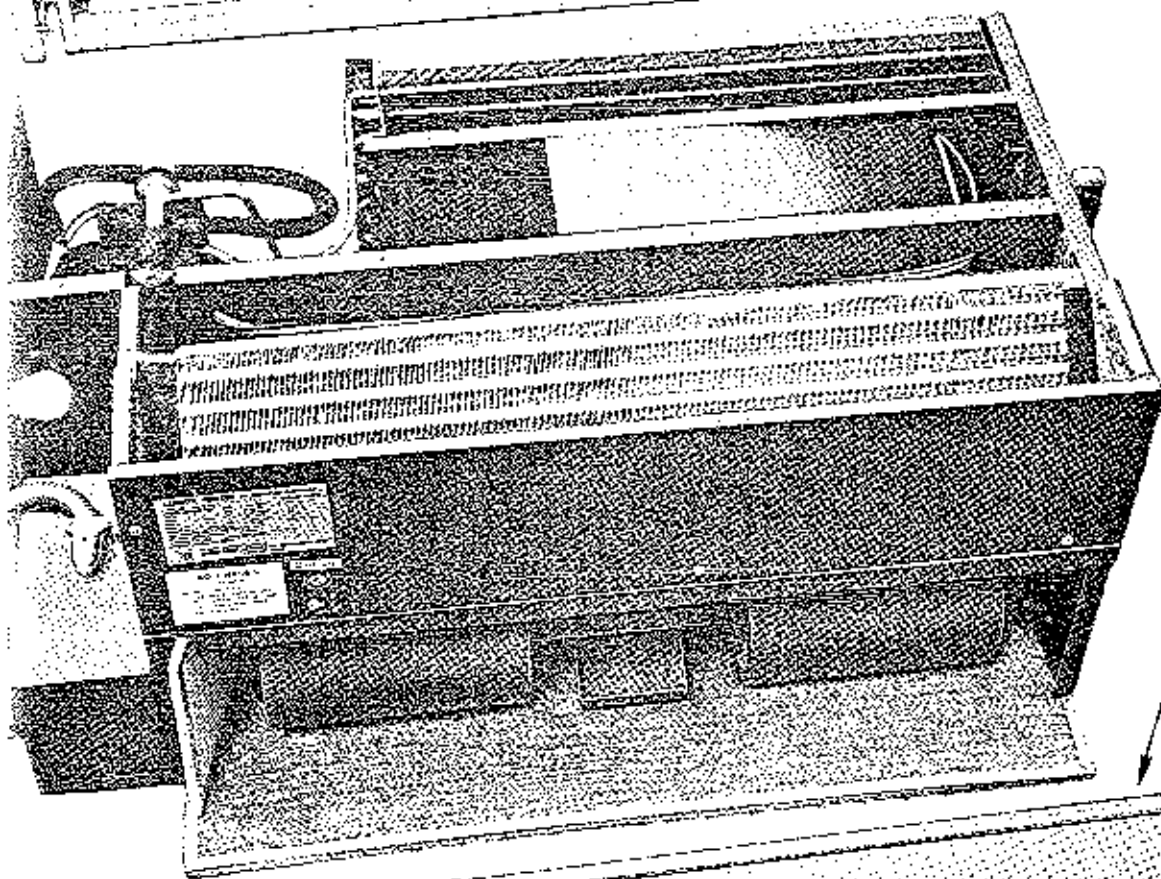

Front Panel

Single piece, removable steel front panel in color matching cabinet is fastened without nuts, bolts or screws.

Temperature Control System Options

GENERAL

The Climate Master Module Control System is designed for individualized comfort control. Many various options and features are offered to provide the designer and owner with the maximum flexibility in control selection and special features to maintain comfort, conserve energy and provide convenience. The systems are a series of factory wired and tested control modules which are independently mounted in each console unit. This provides ease of adjustments and service without removing the major components of the unit.

WALL THERMOSTATS

The control modules shown in this bulletin are shown as unit mounted controls. Each control module or special system can be supplied with a remote mounted wall thermostat to provide the same func-

tion. Low voltage field wiring is required from the unit terminal board to the remotely located thermostat.

All the control modules shown herein can be furnished with a built-in low limit thermostat. When the room temperature drops below 55° the set-back automatically overrides the OFF position and energizes only the room fan and the heating element (electric, steam or hot water).

It is often desirable to control more than one unit in a room from a single thermostat whether unit mounted or wall stat. The necessary relays, transformers, and terminal boards built into the unit require only low voltage field wiring from the Master unit to the Slave unit.

Note: Check manufacturer for UL listing of optional control applications.

Manual Changeover Control, Motorized Damper, Unit Mounted Thermostat (Electric Heat)

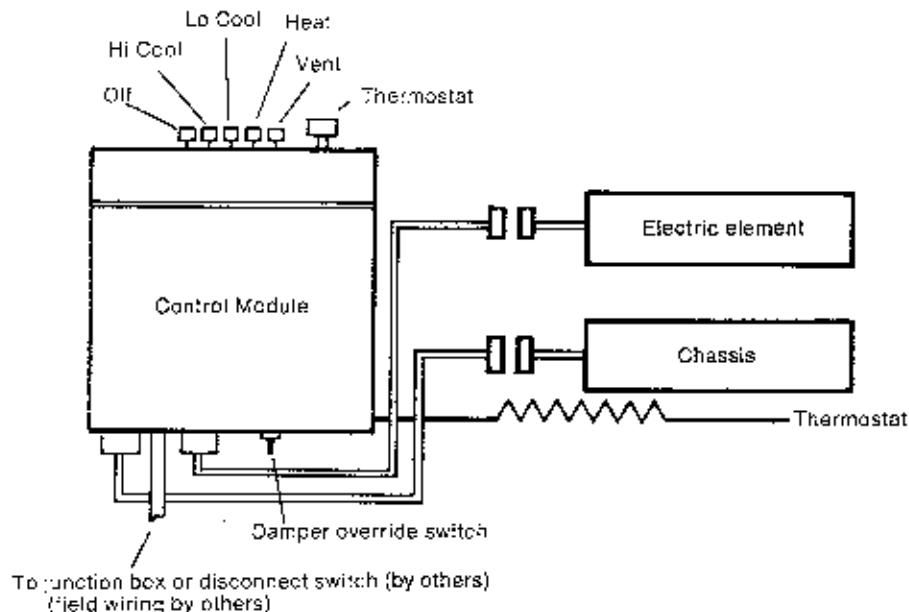

Sequence of Operation

Off button depressed — Unit is completely shut down.

Heat button depressed — Room fan runs continuously on low speed. Motor operated Fresh Air Damper is continuously open. The unit has a concealed toggle switch to allow the F.A. Damper to be closed if desired. Upon a temperature drop the electric heating element is cycled by the unit thermostat to maintain the desired temperature setting.

A high limit cut-out is built in to prevent overheating in case of insufficient air circulation.

Cool button depressed — Room fans run continuously at either high or low speed as selected by occupant. Motor operated damper is open but can be closed manually with the concealed toggle switch. The condenser fans and compressor cycle to satisfy the setting on the thermostat.

Vent button depressed — Damper opens and the roomside fans run continuously.

Temperature Control System Options

Manual Changeover Control, Motorized Damper, Unit Mounted Thermostat (Hydronic Heat)

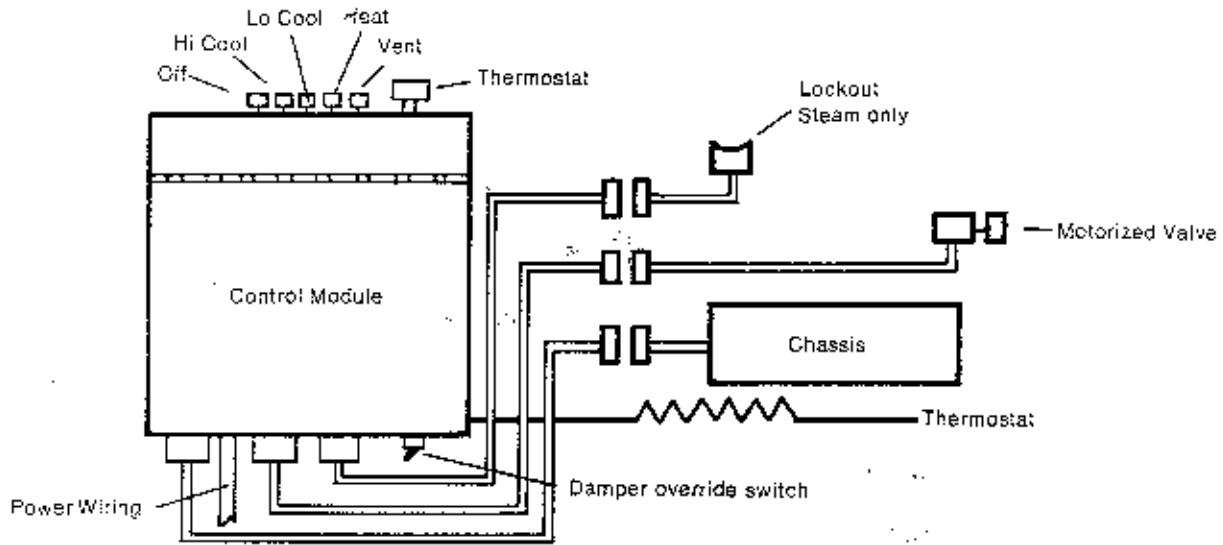

Sequence of Operation

Off button depressed — Same as Electric Heat

Heat button depressed — Upon a temperature drop the motorized valve is cycled to allow either steam

or hot water to enter heating element to satisfy thermostat setting.

Cool button depressed — Same as Electric Heat

Vent button depressed — Same as Electric Heat

Automatic Changeover Control, Motorized Damper, Unit Mounted Thermostat (Electric Heat)

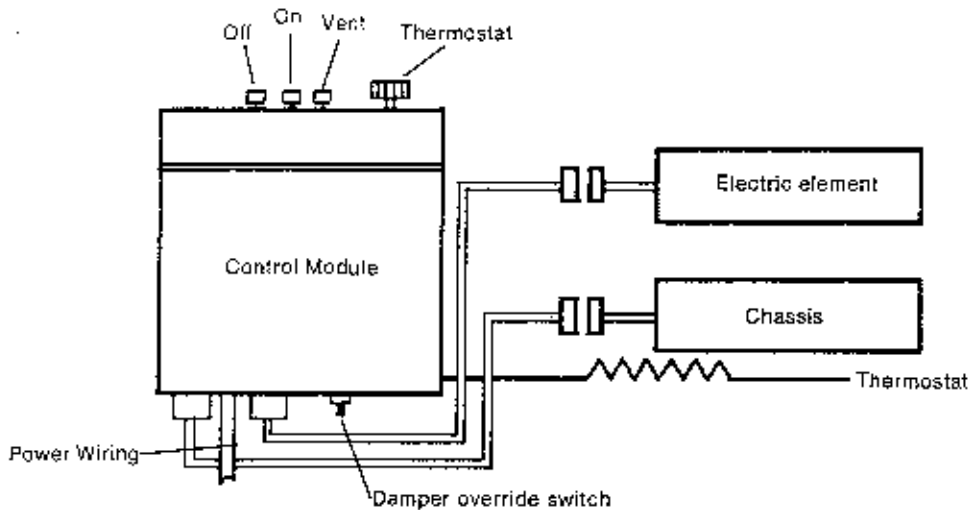

Sequence of Operation

Off button depressed — Unit completely shut off

On button depressed — Room fans run continuously either at high speed in cooling mode or low speed in heating mode automatically. Motor operated damper is continuously open. Upon a rise in

room temperature the condenser fan and compressor are cycled by the thermostat to maintain setting. Upon a drop in temperature the electric element is cycled by the unit thermostat to satisfy the stat setting.

Vent button depressed — Motor operated damper opens and roomside fans run continuously.

Temperature Control System Options

Automatic Changeover Control, Motorized Damper, Unit Mounted Thermostat (Hydronic Heat)

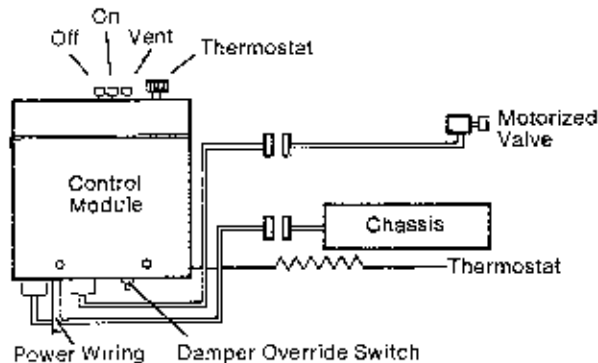

Sequence of Operation

Off button depressed — Unit off

On button depressed — Same except upon a drop in room temperature the motorized valve is cycled to allow steam or hot water to enter the coil to satisfy the thermostat setting.

Vent button depressed — Motor operated damper opens and roomside fans run continuously.

Security Guard Control

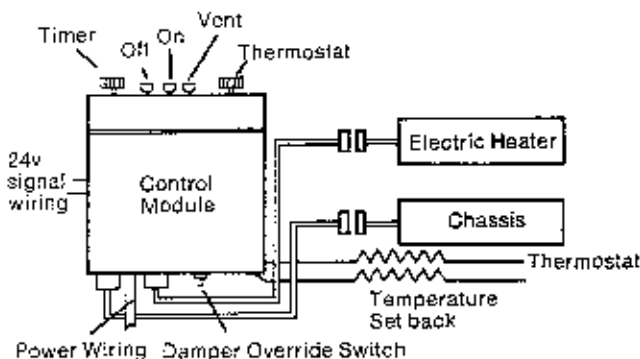

This system can incorporate any of the unit control systems described and can be used with hydronic heat plus incorporating the additional feature of Security Guard.

The **Climate Master Security Guard Control** was designed for office buildings, schools, and any building in which occupancy follows a schedule. In addition to controlling the air conditioning system operation for each day of the week, the control is also capable of "skipping" operation on days such as weekends and holidays. During the "system off" period, however, any occupant who remains in the building can still have normal air conditioning in his space.

The Security Guard Control consists of three basic components:

- 1) Time Clock
- 2) Signal Wiring
- 3) Control Box with Reset Timer and Night Setback Circuit.

OPERATION During normal occupancy hours, the time clock contacts are closed and the signal voltage causes the time delay relay contacts to close. The time delay relay provides a random start so that all the units in the building will not come on simultaneously. With these relay contacts closed, the unit now has operating current and can operate normally to satisfy the room requirements.

At a preset time, the time clock breaks the signal voltage to the time delay relays and the units are shut down. If an occupant wishes to maintain his unit's operation, he must set the unit timer for any interval up to two hours. At the end of this set interval, the unit shuts off. This process may be repeated as often as the occupant needs air conditioning. If the unit is not reset for after hours operation, it will remain off until the time clock is programmed to restart the entire system. During this "off" period, a night setback circuit built into each unit will operate the unit on heating whenever the room temperature drops below 55°F.

OPERATING VOLTAGES Climate Master units are available in 208/230v, or 265v models.

SIGNAL VOLTAGE The 24v signal allows the contractor a cost savings in wiring to the units as low cost Class 2 wiring may be used.

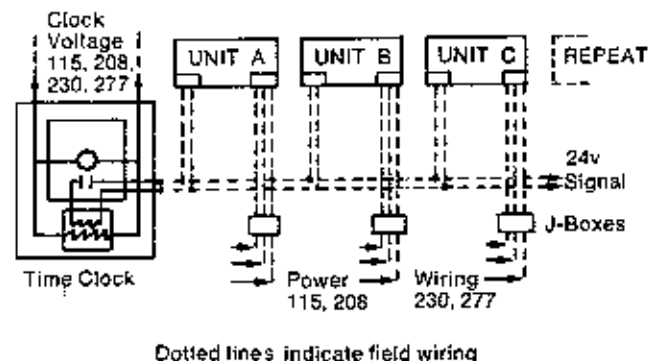

Dotted lines indicate field wiring

Emergency Stand-by

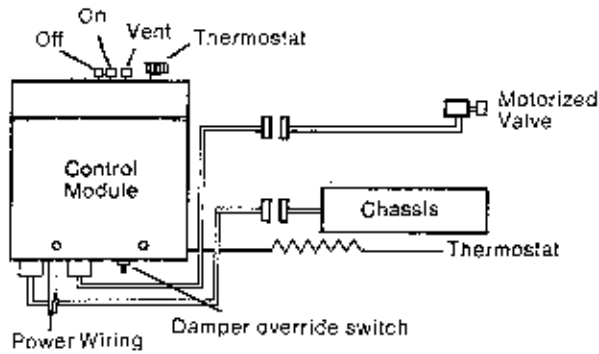

This system can incorporate any of the unit control systems for cooling and hydronic heat systems described plus additional special features.

Used primarily in hospitals, nursing homes and medical centers it permits the occupant to maintain heat in case of building or area power failures. It can be used only when the heat source is steam or hot water.

In case of power failure the switchgear and emergency stand-by generator (switchgear and generator furnished by others) provide power only to the heat cycle of the unit. The cool cycle is automatically locked-out, the condenser fan and com-

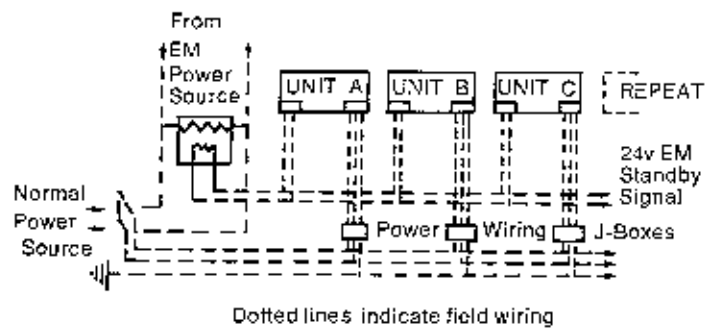

pressor are automatically shut down and/or locked out of the control circuit until the primary power circuit is reenergized.

The room fans, heating valve and vent motor are automatically transferred to the stand-by power circuit until the primary power is back on.

Only the roomside blowers, motorized valve and damper motor are operable during stand-by service from power. During normal operation the unit can be supplied with primary power.

Hot water or steam is supplied to the unit coil from elsewhere also under emergency generator stand-by condition.

Guest Room Control

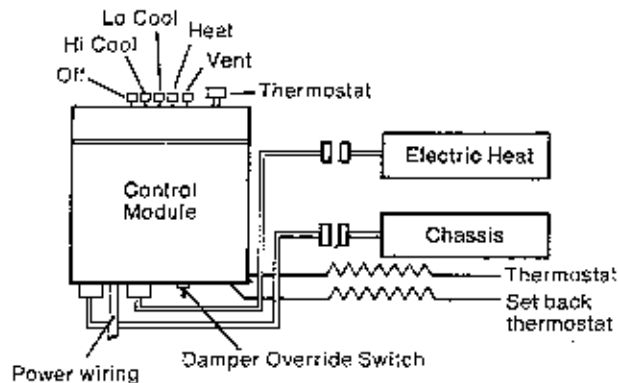

Manual Changeover with Electric Heat Shown

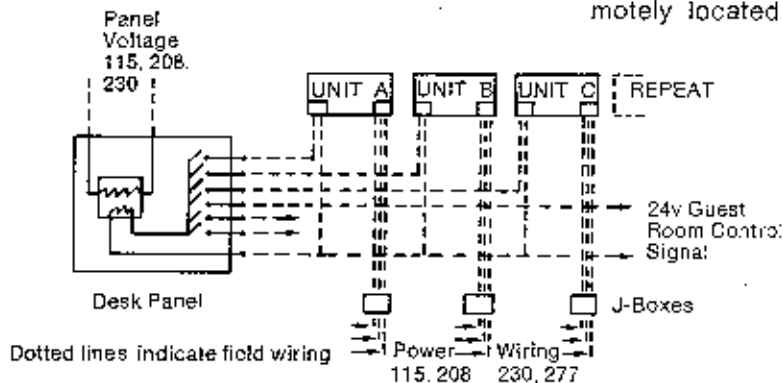

This system can incorporate any of the unit control systems described and be used with hydronic heat plus incorporating the additional feature of Guest Room Control.

Used primarily in hotels and motels it permits the desk clerk to start the unit in each room just before the room is occupied and to switch it off when the room is vacated. All units are equipped with built-in low limit thermostats to activate the unit and override the desk control to maintain a minimum temperature of 55°.

When the desk switch is on the occupant has full individual control of heating, cooling and ventilation as per ordinary systems.

This system is designed to save energy for heating and cooling during unoccupied periods.

The remotely located control panel with 24 volt power supply includes the 24v transformer for 115v power supply, plus an ON-OFF switch for each remotely located unit. In the ON position the unit

operates under normal control by the occupant. In the OFF position the unit is deenergized. The built-in low limit will override the OFF position to allow the fans and heating element to operate to maintain the 55° minimum temperature.

Suggested Bid Form Specifications For Model 700 Console Conditioners

Wallbox:

Shall be constructed from heavy gauge aluminum and shall include temporary weather seal and removable construction supports. Glides shall be die formed in the base to permit easy removal of cooling section. The base shall incorporate a slope of not less than $\frac{1}{4}$ " for drainage purposes. Dimensions shall be 16" high by 36 $\frac{3}{4}$ " wide.

Outdoor Louver:

Shall be extruded aluminum with clear anodized (other) finish and shall snap into place in the wallbox from inside the building without the use of nuts and bolts.

Cooling Section:

Shall consist of a self-contained, hermetically sealed, air-cooled refrigeration system exclusive of controls. Compressor shall be internally spring mounted, with vibration isolators, and shall include PSC Motor overload protection and capacitor. All sheet metal parts constructed of zinc coated heavy gauge steel with acrylic outdoor finish. Provision shall be made for easy removal and insertion of this chassis as a unit. Direct-drive condenser blower assembly shall be a centrifugal type with its own individual motor operating at a speed of not more than 1075 R.P.M. The condenser blower wheel shall be of coated galvanized steel construction and shall perform the function of providing positive condensate removal by breaking the condensate down into vapor and discharging to the outdoors without drip or splash. Cooling section shall contain two double inlet centrifugal evaporator blower wheels connected directly to a two-speed motor with built-in overload protection. This blower assembly shall be easily removed for service. A ventilation door shall be provided in the "bulkhead" between indoor and outdoor sections, capable of supplying up to 70 CFM of outdoor air for ventilation. A clear "see thru" plastic condensate line shall be provided from condensate pan to point of dispersal on condenser blower. All components shall be controlled through a color coded wiring harness terminating in a male plug to be connected to a female plug on the control module. The refrigerant metering device shall consist of a constant pressure automatic valve, designed to prevent frosting of the evaporator coil and short cycling of the compressor. Cooling chassis shall also contain a washable air filter for both fresh air and return air.

Heating Module:

Shall consist of a mounting frame which attaches to the chassis or top of the wall box without interfering with removal of cooling section.

- A. Electric: *Low density finned* sheath electric resistance elements with approved over-heat safety device shall be mounted within the frame. Control wiring shall terminate at a female plug located on the left side of the frame and be connected to a mating plug on the control module.
- B. Hot Water or Steam: A hydronic heating coil shall be mounted within the frame. $\frac{3}{8}$ " O.D. stubs ($\frac{1}{2}$ " nominal copper water line) shall be provided for supply and return connections. A motorized zone valve shall be supplied by the equipment manufacturer. Wiring for the zone valve shall terminate at a female plug to be connected to the control module.

Room Cabinet:

Shall be heavy gauge furniture steel finished in baked enamel. Adjustable kick plate shall be provided. Front shall be heavy gauge steel panel in baked enamel finish matching cabinet. This panel shall be tamper-proof and yet removable without use of tools to provide full access to the cooling chassis. Discharge grille shall be extruded aluminum with polished top and shaded interior. Grill bars shall be on a 15° deflection angle to direct discharge air away from wall surfaces. Return air shall enter the cabinet between kick plate and front panel.

Control Module:

Shall be factory prewired with quick disconnect polarized female plugs. (Consult Climate Master representative for optional control sequences.)

Service:

Include in bid and state who will be responsible for adjusting and starting the conditioners, demonstrating their proper operation to the owner or his representative and rendering necessary maintenance service (other than filter cleaning) during the first year of operation.

Friedrich

**Climate
Master
Series**

Friedrich Air Conditioning & Refrigeration Co.

P. O. Box 1540 • 4200 North Pan Am Expressway
San Antonio, Texas, 78295, U.S.A.

Telex: 76-7481 • Telephone: (512) 225-2000

THE ENERGY ECONOMISERS

Contract Products • Central Cooling & Heating • Room Air Conditioners • Commercial Refrigeration