

**ClimateMaster**

# Climate Master 702/703/704 Series Installation Instructions

Packaged Terminal ME, MP, & SP Air Conditioners and Heat Pumps

---

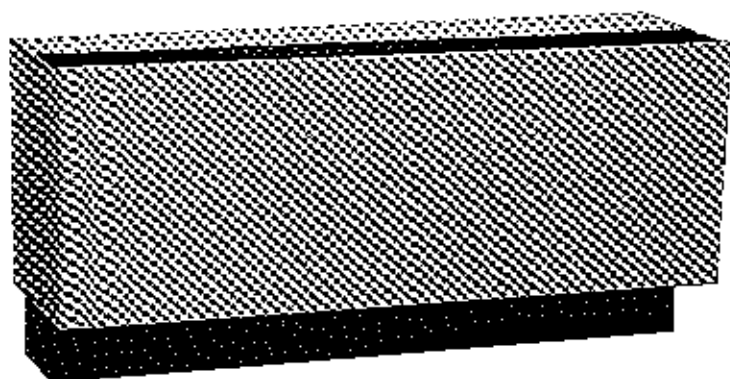

MP

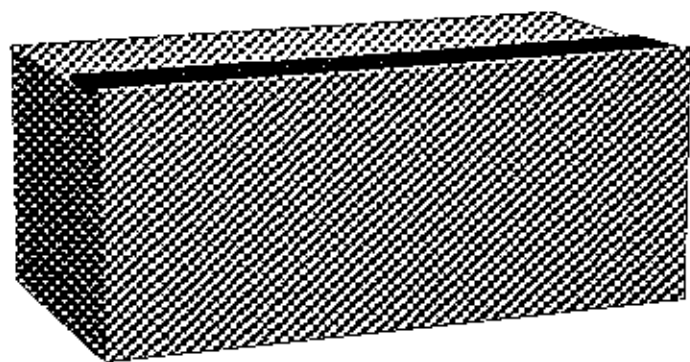

SP

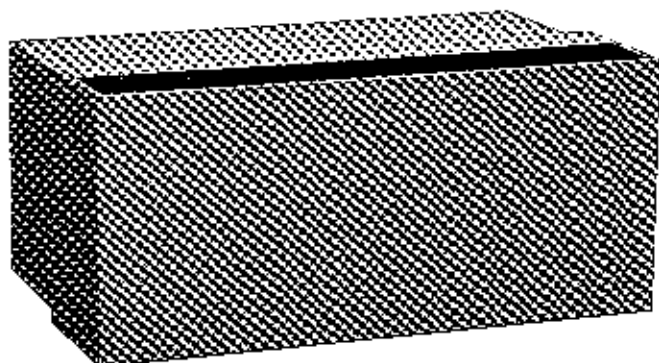

ME

## Description

### 702

The Climate Master 702 Series Packaged Terminal Air Conditioner's (PTAC) are through-the-wall cooling only or combination cool/optional electric heat individual zone air conditioners. The 702 is available in three cabinet styles, the ME, MP, and SP models. The ME, MP, and SP cool/optional electric heat units are provided with a factory installed and factory wired electric heating element. The MP and SP are available with an optional hydronic heat coil for either hot water or steam heat applications. SP cabinet style requires a hydronic sub-base when optional hydronic heat is needed.

### 703

The Climate Master 703 Series Packaged Terminal Heat Pumps (PTHP) are through-the-wall air-to-air heat pumps.

The 703 Series offers heat pump operation to approximately 35° F outdoor air temperature before changing over to electric heat (if applicable).

The options available on the 703 Series are the same as the 702 Series.

### 704

The Climate Master 704 Series Packaged Terminal Heat Pumps (PTHP) are through-the-wall air-to-air extended range heat pumps.

The 704 Series offers heat pump operation to approximately 10° F outdoor air temperature before changing over to 100% electric heat. The electric heat back-up heater has two stages. The first stage is energized at approximately 35° F outdoor air temperature and operates in conjunction with the compressor. The second stage is energized at approximately 10° F outdoor air temperature and compressor heat is locked out.

The 704 Series is equipped with a "timed on" and "temperature sensitive" defrost cycle.

## General

The SP model consists of three sections which are individually packaged as standard: chassis, cabinet/sleeve with front panel, and factory supplied architectural extruded aluminum outdoor louver.

An optional sub-base can be included for support and/or receptacle, disconnect/receptacle, circuit breaker/receptacle options (see Figure 1).

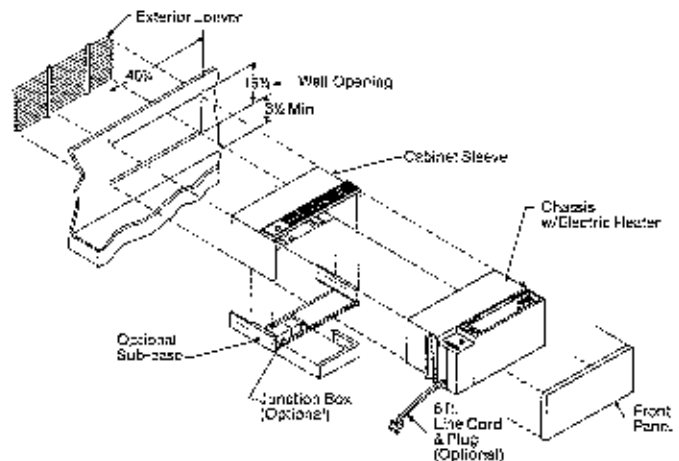

Figure 1. SP Series

The MP model consists of four sections: wallbox, chassis, room cabinet with front panel, and factory supplied architectural extruded aluminum outdoor louver (see Figure 2).

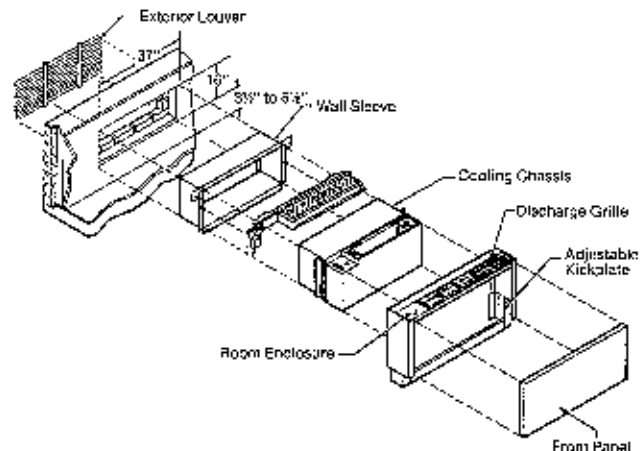

Figure 2. MP Series

The ME model consists of four sections: wallbox, chassis, room cabinet (no front panel), and factory supplied architectural extruded aluminum outdoor louver. The outdoor louver can be an optional factory installed expanded metal louver (see Figure 3).

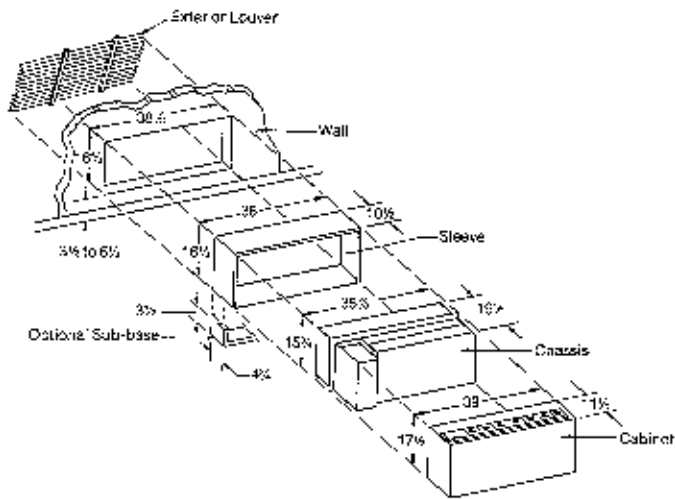

Figure 3. ME Series

The standard control for ME, MP, or SP cabinet styles incorporates stand-by/High Cool/Low Cool and Heat buttons (Manual Changeover Line Voltage) with a self-contained adjustable thermostat. An automatic changeover control—Stand-by/Auto—is an available option.

Positive removal of condensate is provided by evaporation on the condenser coil by means of a multi-blade fan.

An optional fresh air damper is located between the indoor and outdoor sections to provide up to 15% outside ventilation. Motorized or 5 position manually operated dampers are available. All hydronic heat models must specify a motorized damper to prevent accidental freezing of the hydronic coil.

The room discharge grilles can be removed and turned to any one of four positions to change direction of airflow.

### Pre-Installation Checks

Inspect unit(s) and report any damage or missing parts to the carrier's agent. Request an inspection and a report.

The required wall openings for the SP, MP, and ME are shown in Figures 1, 2 and 3, respectively. A minimum distance from floor to bottom of wall openings is 3-1/2", for standard bottom return air intake, to allow for adequate return air. For wall openings less than 3-1/2" from floor to bottom of wall opening, an optional front return air intake is available for SP and MP cabinet styles only.

The SP can be installed in walls 1" to 12" in depth, and will require a factory or field supplied sub-base for walls with depths of 5" or less. A sub-base is also required for SP installations when a line cord and receptacle box, receptacle box with disconnect, or receptacle box with circuit breaker are specified. Optional for walls over 12" in depth are a 4" (ARCE001) and 10" (ARCE002) SP room cabinet extension.

The MP can be installed in walls 1" to 24" in depth, and will require factory supplied support legs for the wall sleeve where wall depths are 5" or less.

The ME can be installed in walls 1" to 24" in depth, and will require a factory or field supplied sub-base for walls with depths of 5" or less. A sub-base is also required for ME installations when a line cord and receptacle box, receptacle box with disconnect, or receptacle box with circuit breaker are specified.

Verify that the voltage rating on the unit rating plate matches the power supply.

### SP Installation

#### Cabinet/Sleeve and Chassis (Figure 1)

1. Attach sub-base (if specified) to cabinet/sleeve with (4) screws provided.
2. If optional power connection box is specified, it is factory attached to a bracket on the left hand side of the optional sub-base.
3. Install cabinet/sleeve in wall opening, flush with outside wall or per louver depth if louver is mounted flush with outside wall.
4. Adjust optional sub-base to wall thickness and lock into position with screws provided.
5. Ensure that the cabinet/sleeve is set horizontally level and vertically plumb. Use the top surface and sides of cabinet/sleeve for leveling. The base has a "built-in pitch" of 1/4" to the outside.
6. Secure the cabinet/sleeve in the wall opening. For masonry wall installation, use masonry anchors. For wood framing, use nails or screws, BUT NEVER THROUGH THE BOTTOM OF THE CABINET/SLEEVE!
7. Caulk between the cabinet/sleeve and the outside wall for a weather tight seal. Caulking may be necessary between the cabinet/sleeve and the finished inside wall.
8. If a condensate drain kit has been specified, install the condensate drain kit per installation instruction provided by Climate Master as a submittal form.
9. Remove the optional, temporary weather panel and install the outdoor architectural anodized louver. Tie a safety line to the louver, then place the louver (fins facing outdoors and blades downward) through the outdoor opening of the cabinet/sleeve. Pull the louver inward until it is squarely seated in the flanged recess of the cabinet/sleeve. Mount the louver using (4) nuts supplied (see

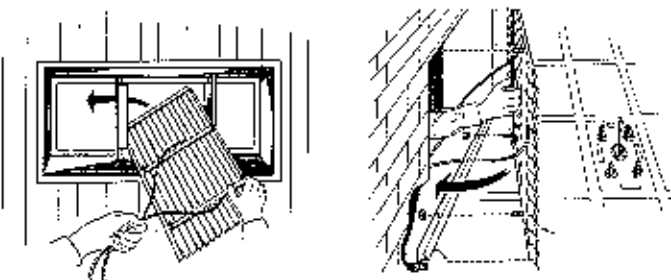

Figure 4. Outdoor Louver

Figure 4). When a louver other than the Climate Master 722 Series louver is used, Climate Master must be notified before purchasing and/or installing.

10. Before installing the chassis, ensure that the closed-cell material is attached to the flanges on the chassis (sides and bottom) for a weathertight seal to the cabinet/sleeve. The weather seal must be removed from the top of the chassis before installing the chassis.
11. Install and attach chassis to the cabinet/sleeve mounting studs (2) and tighten nuts on studs. The nuts are packed in a hardware bag in the cooling chassis carton.
12. Attach the front panel to (4) metal tabs on the cabinet/sleeve. To remove, lift up to disengage slots in the front panel from the metal tabs on the cabinet/sleeve.
13. The cabinet portion of the cabinet sleeve may be protected until ready to use by reinstalling the protective cardboard cover supplied as part of the shipping carton.

## MP Installation

### Wall Box, Room Cabinet and Chassis (Figure 2)

1. Install the wall box flush with the outside wall or per louver depth. The mounting flange of the wall box must never be recessed into the finished interior wall. Do not remove the optional, temporary weather panel during wall box installation (see Figure 5).

NOTE: Match correct wall box with correct depth of wall per location as specified in plans.

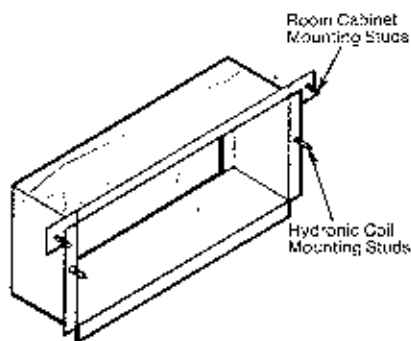

Figure 5. Wall Box

2. Install wall box horizontally level and vertically plumbed. Use the top surface and sides of wall box for leveling. The base of the wall box has a factory "built-in" pitch and should not be used as a leveling reference point.
3. Secure the wall box into position. Use masonry anchors for masonry wall applications and nails or screws for wood framing applications. NEVER secure the wall box through the base (bottom)!
4. Caulk between the wall box and the outside wall for a weathertight seal. Caulking may be necessary between the wall box and the finished inside wall.

5. If a condensate drain kit has been specified, install the condensate drain kit per installation instruction provided by Climate Master as a submittal form.
6. Remove the optional, temporary weather panel and install the outdoor architectural anodized louver. Tie a safety line to the louver, then place the louver (fins facing outdoors and blades downward) through the outdoor opening of the wall box. Pull the louver inward until it is squarely seated in the flanged recess of the wall box. Mount the louver using (4) nuts supplied (see Figure 4). When a louver other than the Climate Master 722 Series louver is used, Climate Master must be notified before purchasing and/or installing.
7. Remove the baffles from the chassis condenser coil when the depth of the wall box being installed is greater than ten inches. Wall boxes with depths greater than ten inches have factory installed baffles.

NOTE: Do not remove baffles from the chassis condenser coil when a ten inch wall box is installed. These baffles prevent air recirculation of the discharge air (see Figure 6).

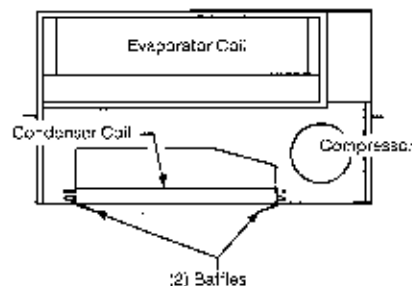

Figure 6. Top View

8. Before installing the chassis, ensure that the closed-cell material is attached to the chassis (sides, bottom and top) for a weathertight seal to the wall box.
9. If a hydronic coil (steam or hot water) is specified (see Figure 7), install the coil on the wall box mounting studs (see Figure 5). The hydronic coil has a metal tab that secures to the top flange of the wall box.
10. Install the chassis (see Figure 8) to the same mounting studs (see Figure 5) as the hydronic coil and tighten the nuts on the screws.

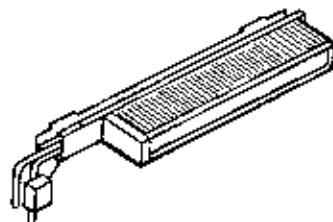

Figure 7. Hydronic Coil

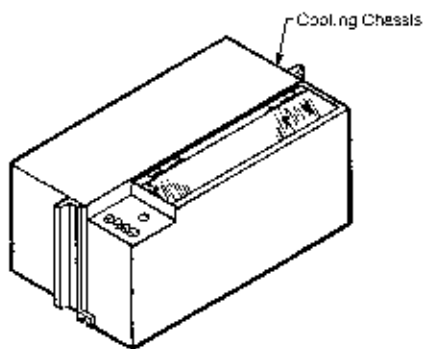

Figure 8. Chassis

11. Check to see that the voltage rating is the same for both the chassis and the hydronic heat section valve. Insert the male connector from the hydronic heat section valve into the female connector at the control module on the top, left hand side of the chassis.
12. Remove the (4) screws from the cabinet kickplate and invert (see Figure 9). Position the kickplate to the cabinet mounting flanges and replace the (4) screws loosely (see figure 10).

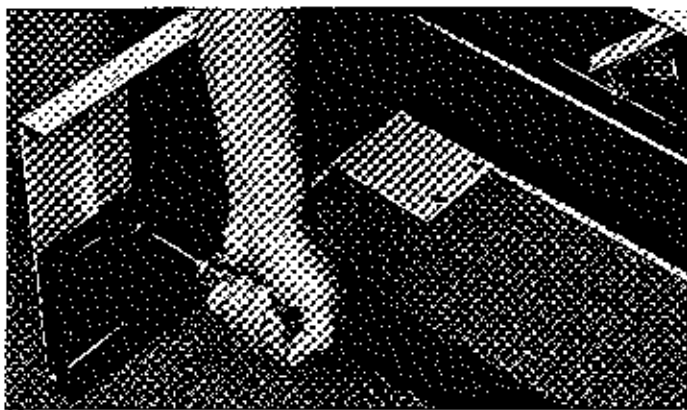

Figure 9.

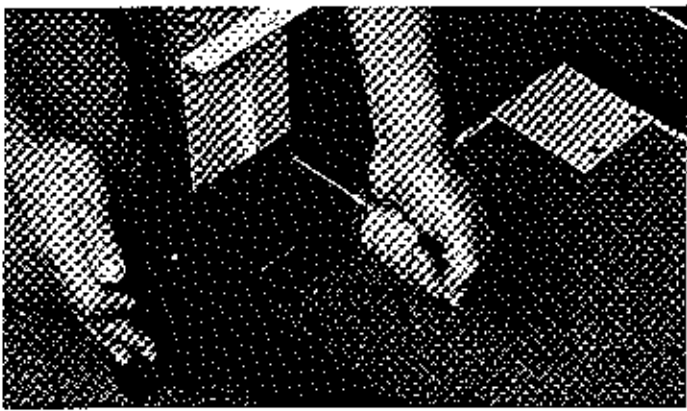

Figure 10.

13. Attach the room cabinet flange (see Figure 5) to the wall box mounting studs. Use the top hole on each cabinet flange if a hydronic coil is not installed. For hydronic coil installations, use the bottom hole on each cabinet flange.
14. Locate the cabinet kickplate in its final position (drop to floor) and tighten the (4) screws.
15. If optional power connection box is specified, mount to front flange of room cabinet with the (2) screws provided. The power connection box can be mounted to the left or right hand flange, depending on the job requirements and the length of the chassis cord.

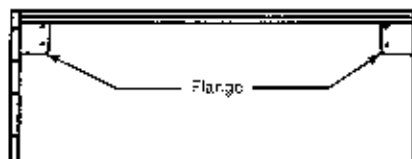

Figure 11. Room Cabinet

16. Attach the front panel to the (4) metal tabs on the cabinet. To remove, lift up to disengage the slots in the front panel from the metal tabs on the cabinet.
17. The cabinet may be protected until ready to use by reinstalling the protective cardboard cover supplied as part of the shipping carton.

## ME Installation

### Wall Sleeve, Room Cabinet and Chassis

NOTE: If optional architectural anodized aluminum louver is used, the wall sleeve may include the optional weather panel. Do not remove this panel until ready to install the louver. If the expanded metal louver is used, it is shipped factory installed in the wall sleeve and no weather panel is needed.

NOTE: If an optional sub-base is used, at least 2" of the wall sleeve must extend into the room beyond the finished inside wall. If no sub-base is used, at least 1/2" of the wall sleeve must extend into the room beyond the finished inside wall.

NOTE: Ensure that the correct wall sleeve is installed at each location, per depth as specified in plans.

1. Install the wall sleeve flush with the outside wall when the expanded metal louver is specified or per louver depth if optional architectural anodized aluminum louver is specified. The wall sleeve must be installed with a 1/4" pitch to the outside to allow proper draining of any condensate.
2. If a condensate drain kit has been specified, install the condensate drain kit per installation instruction provided by Climate Master as a submittal form.

3. Secure the wall sleeve in position. Use masonry anchors for masonry wall applications, and nails or screws for wood framing applications. NEVER secure through the bottom (base) of the wall sleeve.
4. Caulk between the wall sleeve and the outside wall for a weathertight seal. Caulking may be necessary between the wall sleeve and the finished inside wall.
5. If the optional architectural anodized aluminum louver is specified, install this louver. Tie a safety line to the louver, then place the louver (fins facing outdoors and blades downward) through the outdoor opening of the wall sleeve. Pull the louver inward until the louver is squarely seated against the wall sleeve. Mount the louver using (4) nuts supplied (see Figure 4).
6. Remove the baffles from the chassis condenser coil when the depth of the wall sleeve being installed is greater than ten inches. Wall sleeves with depths greater than ten inches have factory installed baffles. NOTE: Do not remove baffles from the chassis condenser coil when a ten inch depth wall sleeve is installed. These baffles prevent air recirculation of the discharge air (see Figure 6).
7. Before installing the chassis, ensure that the closed-cell material is attached to the chassis (sides, bottom, and top) for a weathertight seal to the wall box.
8. Install the sub-base if specified. The sub-base mounts against the wall and the two tabs fit outside the wall sleeve. The two tabs are fastened to the wall sleeve with two screws each. Self-tapping screws are provided (see Figure 12).

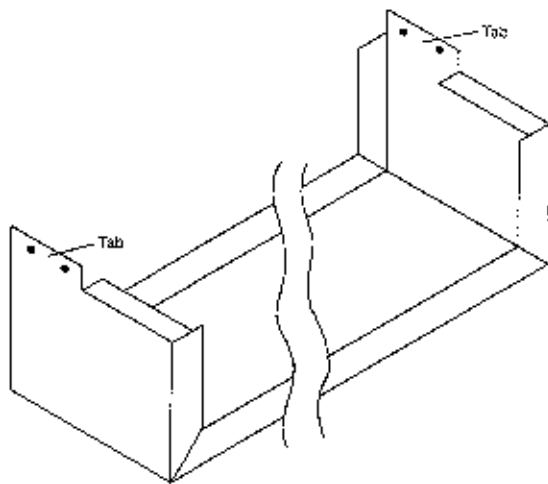

Figure 12. ME Sub-base

9. Slide the chassis into the wall sleeve. Secure the chassis to the wall sleeve with the four screws provided—two on each side. Ensure that the tinnerman clips are fastened to the wall sleeve before securing with screws or the screws will not hold (see Figure 13).

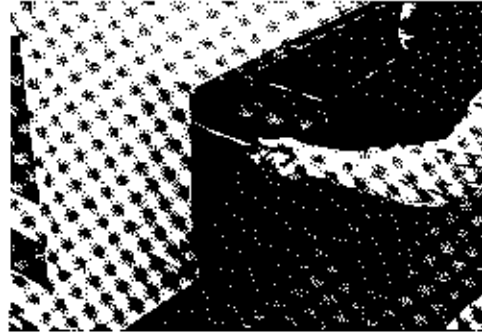

Figure 13.

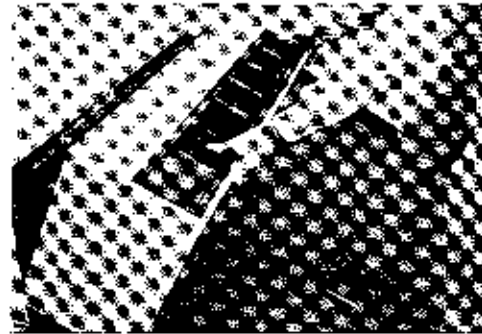

Figure 14.

10. Install the room cabinet. The room cabinet fits into two cutouts at the front of the chassis and hinges back over the chassis. Ensure that the room cabinet is properly seated into the flange of the wall sleeve (see Figure 14).
11. Fasten the cabinet to the wall sleeve using the two screw holes provided.
12. The cabinet may be protected until ready for use by reinstalling the protective cardboard cover supplied as part of the shipping carton.

## Electrical

All wiring should be in accordance with the National Electric Code and local building codes.

The chassis can be either direct connected (hard-wired) or factory supplied/factory installed with an optional line cord and plug. An optional receptacle box, receptacle with disconnect, or receptacle with circuit breaker may be factory supplied/field installed if specified.

Each unit must have a separate branch circuit protected by a fuse or breaker. Refer to the unit rating plate data for proper wire and fuse (breaker) size. Use of extension cords are prohibited.

## Operation

**HEAT**—Adjust thermostat knob clockwise to coolest setting and press HEAT button. Roomside blower will start immediately on high speed. Turn thermostat knob counterclockwise to warmest setting. Heating unit will now operate and discharge air will be warm.

**LOW COOL**—Adjust thermostat knob counterclockwise to the warmest setting. Press LOW COOL button. Roomside blowers will run at low speed. Turn thermostat knob clockwise to coolest setting. Compressor and condenser motor will now operate and discharge air will be cooler.

**HIGH COOL**—With compressor and condenser motor running, press HIGH COOL button. Roomside blower speed will increase.

**VENT (Motorized)**—Press High Cool, Low Cool. The motorized damper will open and provide outside air for ventilation. **NOTE:** Motorized fresh air damper will operate only when the concealed damper override switch is set to the open position. The motorized damper switch is located behind the control button panel.

**VENT (Manual)**—Same as above except damper position must be manually set.

**STBY**—Press stand-by button. All system operations will cease. If a night set-back control is incorporated (factory installed for line voltage controls and field installed for low voltage controls), the unit can operate when the unit is in the stand-by mode if the heating temperature drops below the night set-back temperature setting.

**ON (Optional Automatic Changeover Only)**—Unit will operate on heating or cooling depending on the thermostat setting.

## Maintenance Procedures

Perform the maintenance procedures outlined below at the intervals indicated.

**WARNING: BEFORE SERVICING UNIT, OPEN UNIT DISCONNECT SWITCH TO PREVENT INJURY OR DEATH DUE TO ELECTRICAL SHOCK OR CONTACT WITH MOVING PARTS.**

## Inspect filters every three months.

A regular maintenance schedule is recommended, and the frequency of filter cleaning depends upon the type of occupancy (e.g., hotel, office, school).

**NOTE:** Certain conditions may exist that may require more frequent cleaning of air filter and coils (e.g., pets, deep shag carpeting, etc.).

**CAUTION:** To avoid fouled machinery and extensive unit clean-up, do not operate units without filters in place or use as a temporary heat source during construction.

To remove the filter from the PTAC/PTHP unit, simply slide the filter out of its frame located in the return air opening at the bottom front of the unit. When installing the filter, be sure to use the slide-in rails of the filter frame to guide the filter into the proper position.

## Cleaning Filters

Remove excess dust and lint by rapping dirty side down or by vacuuming. Clean filters by flushing with a stream of water from both the exhaust and intake side. If filters are extremely dirty or linted, fill container with warm water and mild detergent, and "swish" filters in water. Rinse clean and allow to dry before recoating with RP Super Filter Coat.

**Lubricate fan motors annually.** All Climate Master heat pumps are fully lubricated when shipped from the factory; **do not oil initially.** Use a hand pressure oiler to add six drops of SAE-20 Non-Detergent oil to each of the 2 fan motor oil holes once a year; this is most conveniently done at the time of a filter cleaning.

## Safety

Servicing of our conditioning systems should be performed by qualified personnel only, because of hazards due to electrical components and system pressures. Basic maintenance such as cleaning coils and the replacing of filters can be performed by unskilled personnel. When performing service or maintenance on the system, power to the unit should be off. Wear safety goggles and gloves when working with refrigerants. Do not attempt to braze on a system which is under pressure; remove refrigerant first. A quenching cloth, which is used as a heat-sink, is recommended when brazing. Keep a fire extinguisher on hand for all brazing operations.

When using nitrogen and refrigerant for leak testing, always charge the refrigerant in first.

Continuing engineering research results in steady improvements. Therefore, these specifications are subject to change without notice.

No one is authorized to reproduce or alter this document in any way without the written authorization of an officer of the company.

© 1988 Climate Master Printed in U.S.A.  
702/703/704-SD-IO-AS 3/88

**ClimateMaster**

P.O. Box 25788  
Oklahoma City, OK 73125  
(405) 745-6000