

Application, Operation and Maintenance Guide

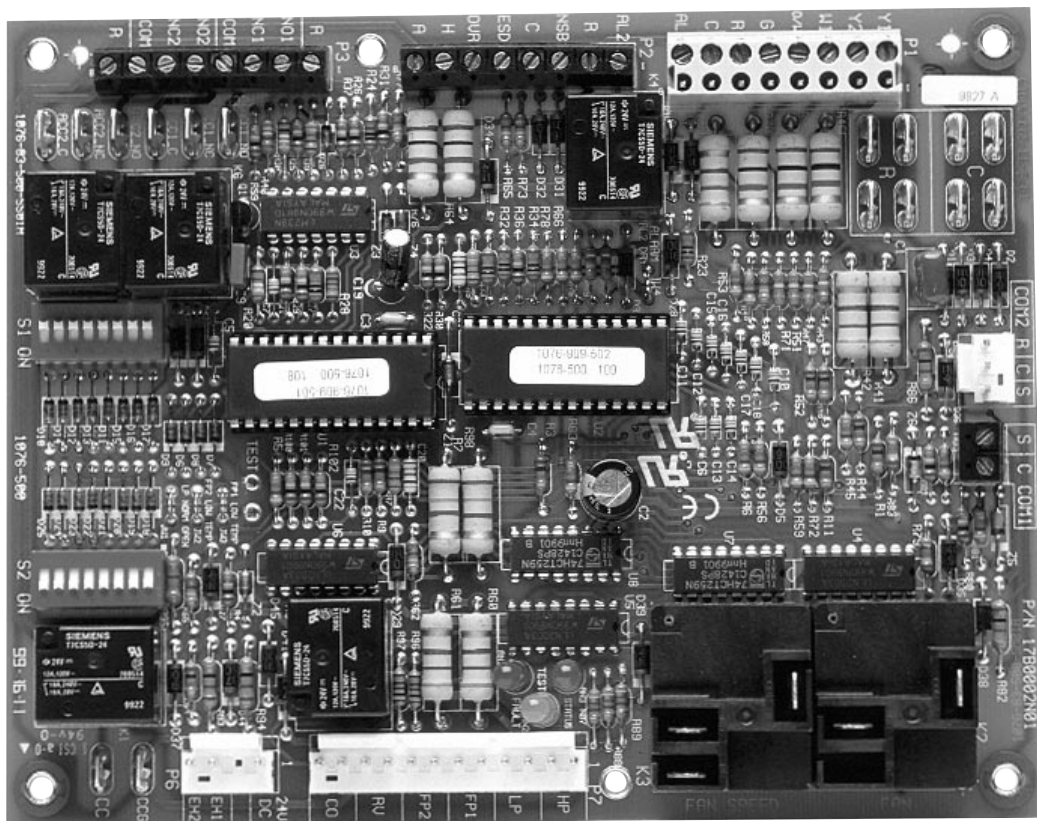

TABLE OF CONTENTS

DXM Overview	3
Physical Dimensions and Layout	3
General Operating Parameters	4
Control Features	4
Field Selectable Inputs	4
Safety Features	6
Diagnostic Features	7
Unit Operation Description	8
Special Application Notes	9
Thermostat Inputs	10
Other Outputs	13
Typical Schematic	14
Product Design and Application Notes	15
Sensors / Thermistors	15
Thermostat Details	16
Troubleshooting	17

DXM / CXM Electronic Control Features Comparison

Basic Features	E/Mech	CMC-2001	CMC-2005	CMC-2010	CXM	DXM	DXM-Lon
High and Low Refrigerant Pressure Protection	S	S	S	S	S	S	S
Low Water Flow Protection	Klixon	Klixon	Klixon	Klixon	Thermistor	Thermistor	Thermistor
Anti-Short-Cycle Time-Delay	O	S	S	S	S	S	S
Emergency Shutdown	O	S	S	S		S	S
Random Start	O	S	S	S	S	S	S
Night Setback with Override	O	S	S	S		S	S
Condensate Overflow Sensor	O	S	S	S	S	S	S
Pump Restart		S	S	S		S	S
Alarm (dry contact output)	O	O	O	O	S	S	S
Outdoor Air Damper Control		E	E	E		S	S
Motorized Water Valve Control		E	E	E	S	S	S
T-Stat Inputs Compatible with Triacs	S				S	S	S
True 24 VAC Thermostat Signals	S				S	S	S
Advanced Features							
Reduced Reversing Valve Operation		S	S	S		S	S
High/Low Fan Speed			S	O		S	S
Intelligent Reset		S	S	S	S	S	S
High and Low Voltage Protection		S	S	S	S	S	S
Air Coil Freeze Protection					S	S	S
Thermostat Type Select (Y,O or Y,W)						S	S
Electric Heat Control Outputs					S	S	S
Hot Gas Reheat Control						S	S
Boilerless Electric Heat Control						S	S
2 Stage Compressor Capacity Control						S	S
Dehumidistat Input						S	S
Reversing Valve Mode Select (O or B)						S	S
Hydronic Economizer Control						S	S
Freeze Setpoint Select (water, antifreeze)					S	S	S
Multiple Units on One Thermostat		3	3	3		3	3
Service and Reliability Features							
CE Approval					S	S	S
Unit Performance Sentinel (UPS)					S	S	S
Service Test Mode		S	S	S	S	S	S
LED Fault and Status Lights		S	S	S	S	S	S
Removable Low Voltage Connector						S	S
Noise Immune Communication Protocol						S	S
Harness-Type Factory Wiring Connectors					S	S	S
Fully Noise-Tested Design					S	S	S
DDC / Energy Management Features							
Echelon / LonMark compatible					O	O	S
Johnson Controls Metasys compatible				S			S
Leaving Water Temperature Display				S			S
Leaving Air Temperature Display				S			S
Demand Load Shed		S	S	S			S
Room Air Temperature and Setpoint Display				S			S

S = Standard O = Optional E = Either WV or OAD

Rev. 5/24/00 m

DXM-Lon: With LonMark Module

E/Mech = ElectroMechanical Controls

DXM Overview

The DXM Electronic Control is a robust, microprocessor based heat pump controller that is advanced and feature-laden for maximum application flexibility. The DXM control has all of the basic CXM control features plus additional inputs and outputs which allow for extensive system capability. The DXM control has relay outputs for compressor, fan, fan speed, reversing valve, alarm relay, and 2 configurable accessory outputs. There are 3 LED's which provide status indication.

There are inputs for safety pressure switches, freeze protection thermistors, condensate overflow sensor, dip

switch selection inputs, thermostat inputs, night setback inputs, and emergency shutdown input.

There are also 2 communications ports: one for communications with DXM dual compressor heat pumps, and another for communications with DXM slaved heat pumps.

CM Part Number:

17B0002N01 DXM Control Board

Physical Dimensions and Layout

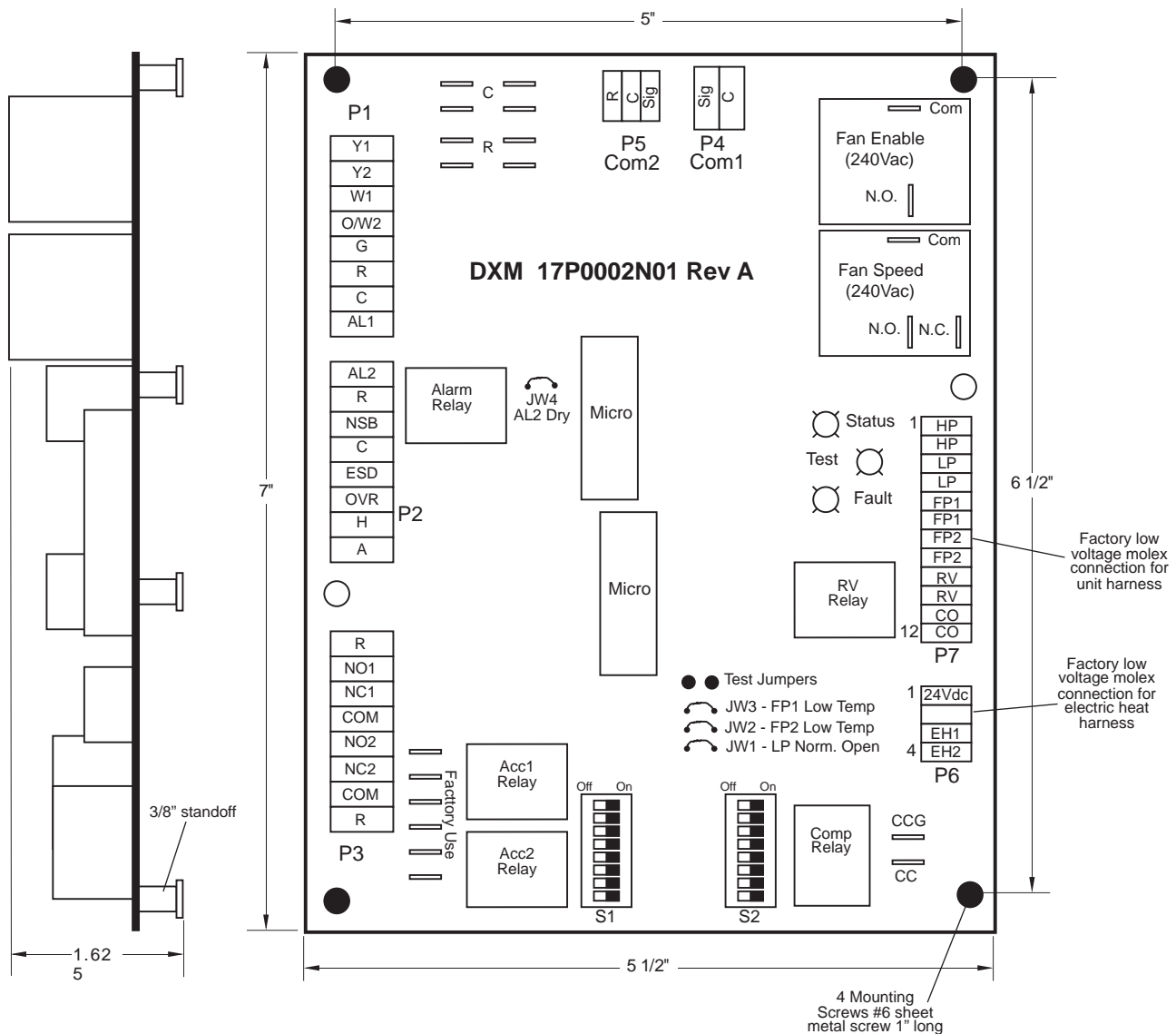

General Operating Parameters

The following are general operating parameters for the DXM control:

Operating Environment: -40°F to 176°F and up to 95% relative humidity, non-condensing.

Storage Environment: -40°F to 185°F and up to 95% relative humidity, non-condensing.

Power Requirements:

DXM only power draw -

- Normally 8 VA draw at 24VAC
- Maximum 12 VA draw at 24VAC. A dedicated 24VAC, 50-60Hz, 1Ph, 40VA transformer minimum is required for typical WSHP application.

Relay and Connection Contact Ratings:

The following relays are mounted on the DXM control:

Compressor Relay: 40VA at 24Vac

Alarm Relay: 28VA at 24Vac

Reversing Valve: 28VA at 24Vac

Accessory Relay 1: 28VA at 24Vac

Accessory Relay 2: 28VA at 24Vac

Fan Enable Relay: 1 HP at 240Vac

Fan Speed Relay: 1 HP at 240Vac

Connection ratings on the DXM control:

‘A’ terminal: 20VA at 24Vac. Larger solenoid valve draw should be used with accessory relays.

Grounding: The control board is grounded through two of the metal standoffs.

Basic Control Features

- Anti-short cycle protection
- High and Low pressure cutouts
- High and Low voltage cutouts
- Water Coil freeze protection
- Air Coil freeze protection
- Random Start
- Status LED, Test LED, and Fault LED
- Reset Lockout at unit or disconnect
- Intelligent Reset
- Condensate Overflow sensor
- Test Mode
- Electric Heat Outputs
- Accessory Water Valve Connection
- Optional LonWorks Control

Advanced Control Features

- Two accessory relays configurable for multiple applications
- Night setback with override capability
- Emergency shutdown capability
- Communications port for DXM dual compressor applications
- Communications port for DXM slave heat pump applications
- Intelligent fan speed capabilities
- Boilerless electric heat
- Removable thermostat connector for ease of installation and service
- Accepts heat pump (Y,O) or heat/cool (Y, W) thermostat types
- Accepts heat pump thermostats with O or B reversing valve control logic
- Dehumidistat input for advanced functions

Field Selectable Inputs

Test Mode – Test Mode allows the service personnel to check the operation of the control in a timely manner. By **momentarily** shorting the test terminals, the DXM control enters a 20 minute Test Mode period in which all time delays are sped up 15 times. During Test Mode, the Test LED will turn on. For Diagnostic ease at the thermostat, the alarm relay will also cycle during test mode. The Alarm relay will cycle on and off similar to the fault LED to indicate a code representing the last fault, at the thermostat. **NOTE: Code 1 indicates there is no fault in memory; stated differently, the control has not faulted since the last power-down to power-up sequence. Test mode can be exited by shorting the test terminals for 3 seconds. Test mode can also be entered and exited by cycling the G input, 3 times within a 60 second time period.**

Retry Mode - If the control is attempting a retry of a fault, the status LED will slow flash (slow flash=one flash every 2 seconds) to indicate the control is in process of retrying.

NOTE: In the following field configuration options, jumper wires should be clipped ONLY when power is removed from the DXM control.

Water Coil Freeze Protection Limit Setting - Jumper 3 (JW3-FP1 Low Temp) provides field selection of temperature limit setting for FP1 to be 30°F or 10°F. Not Clipped=30°F. Clipped=10°F.

Air Coil Freeze Protection Limit Setting - Jumper 2 (JW2-FP2 Low Temp) provides field selection of temperature limit setting for FP2 to be 30°F or 10°F. Not Clipped=30°F. Clipped=10°F.

Alarm Relay Setting - Jumper 4 (JW4-AL2 Dry) provides field selection of Alarm Relay terminal AL2 to be jumpered to 24Vac or to be dry (no connection).

Not Clipped=AL2 connected to R. Clipped=AL2 dry contacts (no connection).

Low Pressure Normally Open – Jumper 1 (JW1-LP Norm Open) Provides field selection for Low Pressure input to be Normally Closed or Normally Open.

Not Clipped = LP Normally Closed. Clipped = LP Normally Open.

Dip Switches

NOTE: In the following field configuration options, dip switches should only be moved when power is removed from the DXM control to insure proper operation.

Dip Package #1 (S1)

Dip Package #1 is 8 position and provides the following setup selections.

Unit Performance Sentinel Disable - Dip Switch 1.1 provides field selection to disable the UPS feature.

On = Enabled. Off = Disabled.

Compressor Relay Staging Operation - Dip 1.2 provides selection of Compressor Relay Staging Operation. The compressor relay can be selected to turn on with Stage 1 or Stage 2 call from the thermostat. This is used with Dual Stage units (2 compressors where 2 DXM controls are being used) or with Master/Slave applications. In Master/Slave applications, each compressor and fan will stage according to its appropriate dip 1.2. If set to stage 2, the compressor will have a 3 second on-delay before energizing during a Stage 2 demand. Also, if set for stage 2, the Alarm relay will NOT cycle during Test Mode.

On=Stage 1. Off=Stage 2.

Thermostat Type (heat/cool) - Dip 1.3 provides selection of Thermostat Type. Heat Pump or Heat/Cool thermostats can be selected. When in Heat/Cool mode, Y1 is input call for Cooling Stage 1, Y2 is input call for Cooling Stage 2, W1 is input call for Heating Stage 1, and O/W2 is input call for Heating Stage 2. In Heat Pump mode, Y1 is input call for Compressor Stage 1, Y2 is input call for Compressor Stage 2, W1 is input call for Heating Stage 3 or Emergency Heat, and O/W2 is the input call for RV (heating or cooling dependent upon dip 1.4).

On=Heat Pump. Off=Heat/Cool.

Thermostat Type (O/B) - Dip 1.4 provides selection of Thermostat Type. Heat Pump Thermostats with “O” output on with Cooling or “B” output on with Heating can be selected.

On=HP Stat with O output with Cooling. Off=HP Stat with B output with Heating.

Dehumidification Mode - Dip 1.5 provides selection of normal or dehumidification fan mode. In dehumidification mode, the Fan Speed relay will remain off during Cooling Stage 2. In normal mode, the Fan Speed relay will turn on during Cooling Stage 2.

On=Normal fan mode. Off=Dehumidification mode.

DIP 1.6 Not Used - Dip 1.6 Is not used.

Boilerless Operation - Dip 1.7 provides selection of Boilerless Operation. In Boilerless mode, only the compressor is used for heating mode when FP1 is above the temperature specified by the setting of dip 1.8. If dip 1.8 is set for 50°F, then the compressor is used for heating as long as FP1 is above 50°F. Below 50°F, the compressor is not used and the control goes into Emergency Heat mode, staging on EH1 and EH2 to provide heating. If a thermal switch is being used in place of the FP1 thermistor, then only the compressor will be used for heating mode when the FP1 terminals are closed. If the FP1 terminals are open, then the compressor is not used and the control goes into Emergency Heat mode.

On=normal. Off=Boilerless operation.

Boilerless changeover temperature - Dip 1.8 provides selection of Boilerless changeover temperature setpoint.

On=50°F. Off=40°F.

Table 1. Accessory Relay 1 Configuration

Dip 2.1	Dip 2.2	Dip 2.3	Acc1 Relay Option
On	On	On	Cycle with fan
Off	On	On	Digital NSB
On	Off	On	Water valve – slow opening
On	On	Off	OAD

All other DIP combinations are invalid

Dip Package #2 (S2)

Dip Package #2 is 8 position and provides the following setup selections.

Accessory1 relay personality - Dip 2.1 provides selection of Acc1 relay personality. See Table 1.

Accessory1 relay personality -Dip 2.2 provides selection of Acc1 relay personality. See Table 1.

Accessory1 relay personality -Dip 2.3 provides selection of Acc1 relay option. See Table 1.

Accessory2 relay personality - Dip 2.4 provides selection of Acc2 relay personality. See Table 2.

Accessory2 relay personality -Dip 2.5 provides selection of Acc2 relay personality. See Table 2.

Accessory2 relay personality -Dip 2.6 provides selection of Acc2 relay option. See Table 2.

Auto Dehumidification Fan Mode or High Fan Mode - Dip 2.7 provides selection of Auto Dehumidification Fan Mode or High Fan Mode. In Auto Dehumidification Mode, the Fan Speed relay will remain off during Cooling Stage 2 IF the H input is active. In High Fan Mode, the Fan Enable and Fan Speed relays will turn on when the H input is active.

On=Auto Dehumidification Mode. Off=High Fan Mode.

DIP 2.8 Not Used - Dip 2.8 not used.

Table 2. Accessory Relay 2 Configuration

Dip 2.4	Dip 2.5	Dip 2.6	Acc2 Relay Option
On	On	On	Cycle with compressor
Off	On	On	Digital NSB
On	Off	On	Water valve – slow opening
On	On	Off	OAD

All other DIP combinations are invalid

Safety Features

The following safety features are provided to protect the compressor, heat exchangers, wiring and other components from damage caused by operation outside of design conditions.

Anti-Short Cycle Protection - The control features a 5 minute anti-short cycle protection for the compressor.
NOTE: The 5 minute anti-short cycle also occurs at power up.

Random Start - The control features a 5-80 second random start upon power up. The random start delay will be present after a control power up and after returning from Night Setback or Emergency Shutdown modes.

Extended Compressor Operation Monitoring - If the compressor relay has been on for 4 continuous hours, then the control will automatically turn off the compressor relay and wait the short cycle protection time. All appropriate safeties including the LP will be monitored during the off time. If all operation is normal, then if the compressor demand is still present, the control will turn the compressor back on.

Fault Retry - In Fault Retry mode, the Status LED begins slow flashing to signal that the control is trying to recover from a fault input. The Fault LED will also begin flashing a code representing the last fault, which occurred. The DXM control will stage off the outputs and then “try again” to satisfy the thermostat call for compressor. Once the thermostat input calls are satisfied, the control will continue on as if no fault occurred. If 3

consecutive faults occur without satisfying the thermostat call for compressor, then the control will go to Lockout mode. The last fault causing the lockout will be stored in memory and is displayed by the Fault LED.

Lockout - In Lockout mode, the Status LED will begin fast flashing. The Fault LED will be flashing a code representing the last fault, which occurred that caused the lockout. The compressor relay is turned off immediately. Lockout mode can be soft reset via the thermostat by removing the call for compressor, or can be hard reset via the disconnect. The last fault causing the lockout will be stored in memory and is displayed by the Fault LED.

Lockout with Emergency Heat - If the DXM is configured for Heat Pump thermostat mode (see dip 1.3), the DXM is in Lockout mode, and the W input becomes active, then Emergency Heat mode will occur during Lockout.

High Pressure Switch - When the High Pressure Switch opens due to high refrigerant pressures, the Compressor relay is de-energized immediately since the High Pressure Switch is in series with the compressor contactor coil. The High Pressure Fault recognition is immediate as well. The Fault LED will immediately begin flashing Code 2 when a High Pressure Fault occurs.

High Pressure Lockout Code = 2

Example: 2 quick flashes, 10-sec pause, 2 quick flashes, 10-sec. pause, etc.

Low Pressure Switch - The Low Pressure Switch must be open and remain open for 30 continuous seconds during a compressor “on” cycle to be recognized as a Low Pressure fault. If the low pressure switch is open for 30 seconds prior to compressor power up it will be considered a low pressure (loss of charge) fault. The Low Pressure Switch input is bypassed for the initial 60 seconds of a compressor run cycle. The Fault LED will immediately begin flashing Code 3 when a Low Pressure Fault occurs.

Low Pressure Lockout Code = 3

Water Coil Freeze Protection (FP1) - The FP1 thermistor temperature must be below the selected freeze protection limit setting for 30 continuous seconds during a compressor run cycle to be recognized as a FP1 fault. The FP1 input is bypassed for the initial 60 seconds of a compressor run cycle. The Fault LED will immediately begin flashing Code 4 when a FP1 Fault occurs.

FP1 Lockout Code = 4

Air Coil Freeze Protection (FP2) - The FP2 thermistor temperature must be below the selected freeze protection limit setting for 30 continuous seconds during a compressor run cycle to be recognized as a FP2 fault. The FP2 input is bypassed for the initial 60 seconds of a compressor run cycle. The Fault LED will immediately begin flashing Code 5 when a FP2 Fault occurs.

FP2 Lockout Code = 5

Condensate Overflow - The Condensate Overflow sensor must sense overflow levels for 30 continuous seconds to be recognized as a CO fault. Condensate Overflow will be monitored at all times. The Fault LED will immediately begin flashing Code 6 when a Condensate Overflow Fault occurs.

CO Lockout Code = 6

Over/Under Voltage Shutdown - An Over/Under Voltage condition exists when the control voltage is outside the range of 19Vac to 30Vac. Over/Under Voltage Shutdown is self-resetting in that if the voltage comes back within range of 19Vac to 30Vac for at least 0.5 seconds, then normal operation is restored. This is not considered a fault or lockout. If the DXM is in over/under voltage shutdown for 15 minutes, the alarm relay will close.

Over/Under Voltage Shutdown Code = 7

Unit Performance Sentinel-UPS (patent pending) - The UPS feature warns when the heat pump is operating inefficiently. A UPS condition exists when:

- a) In heating mode with compressor energized, if FP2 is greater than 125°F for 30 continuous seconds, or
- b) In cooling mode with compressor energized, if FP1 is greater than 125°F for 30 continuous seconds, OR FP2 is less than 40°F for 30 continuous seconds.

If a UPS condition occurs, the control will immediately go to UPS warning. The status LED will remain on as if the control is in Normal mode. (see "LED and Alarm Relay Operation Table"). Outputs of the control, excluding Fault LED and Alarm Relay, will NOT be affected by UPS. The UPS condition cannot occur during a compressor off cycle. During UPS warning, the Alarm Relay will cycle on and off. The cycle rate will be On for 5 seconds, Off for 25 seconds, On for 5 seconds, Off for 25 seconds, etc...

Unit Performance Sentinel Warning Code = 8

Diagnostic Features

The Status LED and Fault LED on the DXM control advises service personnel of the current status of the DXM control. The Status LED will indicate the current mode that the DXM control is in. The Fault LED will ALWAYS flash a code representing the LAST fault in memory. If there is no fault on memory, then the Fault LED will flash Code 1. See Table 3 for a complete listing of codes.

Table 3. LED and Alarm Relay Output Table

Description of Operation	Status LED green	Test LED yellow	Fault LED red	Alarm Relay
Normal Mode	On	Off	Flashing Appropriate Code	Open
Normal Mode with UPS	On	Off	Flashing Code 8	Cycle (closed 5 sec, open 25 sec, ...)
DXM is non-functional	Off	Off	Off	Open
Test Mode	-	On	Flashing Appropriate Code	Cycling Appropriate Code
Night Setback	Flashing Code 2	-	Flashing Appropriate Code	-
ESD	Flashing Code 3	-	Flashing Appropriate Code	-
Invalid T-stat Inputs	Flashing Code 4	-	Flashing Appropriate Code	-
No Fault in Memory	On	Off	Flashing Code 1	Open
HP Fault	Slow Flash	Off	Flashing Code 2	Open
LP Fault	Slow Flash	Off	Flashing Code 3	Open
FP1 Fault	Slow Flash	Off	Flashing Code 4	Open
FP2 Fault	Slow Flash	Off	Flashing Code 5	Open
CO Fault	Slow Flash	Off	Flashing Code 6	Open
Over/Under Voltage	Slow Flash	Off	Flashing Code 7	Open (closed after 15 minutes)
HP Lockout	Fast Flash	Off	Flashing Code 2	Closed
LP Lockout	Fast Flash	Off	Flashing Code 3	Closed
FP1 Lockout	Fast Flash	Off	Flashing Code 4	Closed
FP2 Lockout	Fast Flash	Off	Flashing Code 5	Closed
CO Lockout	Fast Flash	Off	Flashing Code 6	Closed

NOTES:

- a) "Flashing Appropriate Code" means that the Fault LED will ALWAYS flash a code representing the LAST fault in memory. If there is no fault in memory, the Fault LED will flash code 1.
- b) Codes will be displayed with a 10 second Fault LED off period.
- c) Slow flash will be 1 flash per every 2 seconds.
- d) Fast flash will be 2 flash per every 1 second.

Unit Operation Description

PowerUp

The unit will not operate until all the inputs and safety controls are checked for normal conditions. **NOTE: The compressor will have a 5-minute anti-short cycle delay at power-up.**

Standby/Fan Only

In Standby mode, the compressor will be off. The Fan Enable, Fan Speed, and RV relays may be on if appropriate inputs are present. If there is a Fan 1 demand, then the Fan Enable relay will turn on immediately. If there is a Fan 2 demand, then the Fan Enable and Fan Speed relays will turn on immediately. **NOTE: Dip1.5 (Dehum Fan Mode Select) has no effect upon Fan 1 and Fan 2 outputs.**

The RV relay will not directly track the input demands for RV, the DXM control will employ "smart RV" control. This ensures that the RV will only switch positions if the thermostat has called for a heating/cooling mode change.

Heating Stage 1

In Heating Stage 1 mode, the Fan Enable and Compressor relays are turned on immediately. If configured as Stage 2

(dip1.2=off), then the compressor and fan will not turn on until there is Stage 2 demand. The Fan Enable relay and Compressor relay are turned off immediately when the Heating Stage 1 demand is removed. The control reverts to Standby mode. If there is a Master/Slave situation or a Dual Compressor situation, all Compressor relays and related functions will track with their associated dip1.2.

Heating Stage 2

In Heating Stage 2 mode, the Fan Enable and Compressor relays remain on. The Fan Speed relay is turned on immediately.

The Fan Speed relay is turned off immediately when the Heating Stage 2 demand is removed. The control reverts to Heating Stage 1 mode. If there is a Master/Slave situation or a Dual Compressor situation, all Compressor relays and related functions will track with their associated dip1.2.

Heating Stage 3

In Heating Stage 3 mode, the Fan Enable, Fan Speed and Compressor relays will remain on. EH1 output is turned on immediately. With continuing Heating Stage 3 demand, EH2 will turn on after 10 minutes. EH1 and EH2 are turned off immediately when the Heating Stage 3 demand is removed. The control reverts to Heating Stage 2 mode. During Heating Stage 3 mode, EH2 will be off (or will turn off if already on) if FP1 is greater

than 45°F AND FP2 is greater than 110°F (FP2 greater than 110°F includes the condition that FP2 is shorted). This condition will have a 30-second recognition time. During Heating Stage 3 mode, EH1, EH2, Fan Enable and Fan Speed will be on if the G input is not active.

Emergency Heat

In Emergency Heat mode, the Fan Enable and Fan Speed relays are turned on. EH1 is turned on immediately. With continuing Emergency Heat demand, EH2 will turn on after 5 minutes. EH1 and EH2 are turned off immediately when the Emergency Heat demand is removed. The Fan Enable and Fan Speed relays will turn off after a 60-second delay. The control reverts to Standby mode. During Emergency Heat mode, EH1, EH2, Fan Enable and Fan Speed will be on if the G input is not active.

Cooling Stage 1

In Cooling Stage 1 mode, the Fan Enable, Compressor, and RV relays are turned on immediately. If configured as Stage 2 (dip1.2=off), then the compressor and fan will not turn on until there is Stage 2 demand. The Fan Enable and Compressor relays are turned off immediately when the Cooling Stage 1 demand is removed. The control reverts to Standby mode. The RV relay remains on until there is a Heating demand. If there is a Master/

Slave situation or a Dual Compressor situation, all Compressor relays and related functions will track with their associated dip1.2.

Cooling Stage 2

In Cooling Stage 2 mode, the Fan Enable, Compressor, and RV relays remain on. The Fan Speed relay is turned on immediately (see dip1.5). The Fan Speed relay is turned off immediately when the Cooling Stage 2 demand is removed. The control reverts to Cooling Stage 1 mode. If there is a Master/Slave situation or a Dual Compressor situation, all Compressor relays and related functions will track with their associated dip1.2.

Night Low Limit (NLL) Staged Heating

In NLL Staged Heating mode, the OVR input becomes active and is recognized as a call for Heating. (OVR is an alternate means of calling for Heating mode). In NLL Staged Heating mode, the control will immediately go into Heating Stage 1 mode. With an additional 30 minutes of NLL demand, the control will go into Heating Stage 2 mode. With another additional 30 minutes of NLL demand, the control will go into Heating Stage 3 mode.

Special Application Notes

Generally the following applications are based upon configuring the accessory relays.

Cycle with Fan - If an Accessory relay is configured to “cycle with fan”, the Accessory relay will be on any time the Fan Enable relay is on.

Cycle with Compressor - If an Accessory relay is configured to “cycle with compressor”, the Accessory relay will be on any time the Compressor relay is on.

Digital Night Setback - If an Accessory relay is configured for Digital NSB, the Accessory relay will be on any time the NSB input is connected to Ground “C”.

NOTE: If there are no Accessory relays configured for Digital NSB, then the NSB and OVR inputs are automatically configured for “mechanical” operation. See Mechanical NSB operation below.

Mechanical Night Set Back - When the NSB input is connected to Ground “C”, all thermostat inputs (G, Y1,

Y2, W1, and O/W2) are ignored. A thermostat setback Heating call can then be connected to the OVR input. If the OVR input becomes active, then the DXM will enter NLL Staged Heating mode. NLL Staged Heating Mode would then provide heating during the NSB period.

Water Valve/Slow Opening - If an Accessory relay is configured for Water Valve/Slow Opening, the Accessory relay will turn on 60 seconds prior to the Compressor Relay turning on.

Outside Air Damper-If an Accessory relay is configured for OAD, the Accessory relay will normally turn be on any time the Fan Enable relay is on. But, following a return from NSB (NSB input no longer connected to Ground “C”) to Normal Mode, the Accessory relay will not turn on for 30 minutes even if the Fan Enable relay is on. After this 30-minute timer expires, the Accessory relay will turn on if the Fan Enable relay is on.

Thermostat Inputs

Table 10 displays inputs and output signals. Table 4 shows the resulting demand from differing combinations of inputs.

Y1 - Y1 is the input for compressor stage 1 if dip1.3=on. Y1 is the input for Cooling Stage 1 if dip1.3=off.

Y2 - Y2 is the input for compressor stage 2 if dip1.3=on. Y2 is the input for Cooling Stage 2 if dip1.3=off.

W1 - If Y1 and Y2 are active and dip1.3=on, then W1 is the input for Heating Stage 3. If Y1 and Y2 are not active and dip1.3=on, then W1 is the input for Emergency Heat. If dip1.3=off, then W1 is the input for Heating Stage 1.

O/W2 - O/W2 is the input for Reversing Valve relay if dip1.3=on and dip1.4=on. O/W2 is the input for Heating Stage 2 if dip1.3=off. O/W2 is the input for "Heat Mode" if dip1.3=on and dip1.4=off; this means that the thermostat outputs a "B" call when in Heating mode and does NOT have an "O" output. The DXM control will employ "Smart RV" control. This ensures that the RV will only switch positions if the thermostat has called for a heating/cooling mode change.

G - G is the input for Fan Enable relay.

NSB and Override - NSB is the input for Night Setback mode. When Digital NSB is selected via the Accessory relays dipswitch inputs and the NSB input is connected to Ground "C", then the appropriately configured Accessory relay is turned on to signal the digital thermostat to go to Night Setback Setpoints. Stated differently, when configured for Digital NSB mode, the Accessory relay directly tracks the NSB input.

When Digital NSB is NOT selected via the Accessory relays dipswitch inputs and the NSB input is connected to Ground "C", then Y1, Y2, W1 and O/W2 and G are ignored. During this time period, if OVR is momentarily connected to 24Vac, then Y1, Y2, W1 and O/W2 and G are once again monitored for 2 hours. After the 2 hour Override period, the DXM reverts back to ignoring Y1, Y2, W1 and O/W2 and G, assuming the NSB input is still connected to Ground "C". There will be a random start timer when coming back from NSB mode.

NOTE: The maximum number of DXM controls with daisy-chained "NSB" terminals is 75. Also, the maximum total wire resistance of the "NSB" wiring is 500 ohms.

ESD - ESD is the input for Emergency Shutdown mode. When the ESD input is connected to Ground "C", all inputs are ignored and all outputs are turned off. There will be a random start timer when coming back from ESD.

Table 4. Thermostat Inputs with resulting demands

Tstat Inputs					Dip Switch		Resulting Demand #1
G	Y1	Y2	W1	O/W2	Stat (HP/HC) Type Dip 1.3	Stat (O/B)Type Dip 1.4	
					-	-	Standby/Off
x					-	-	F1
-	x			x	HP	O	C1
-	x				HP	B	C1
-	x				HC	-	C1
-	-	x		x	HP	O	C2
-	-	x			HP	B	C2
-	-	x			HC	-	C2
-	x				HP	O	H1
-	x			x	HP	B	H1
-			x		HC	-	H1
-	-	x			HP	O	H2
-	-	x		x	HP	B	H2
-			-	x	HC	-	H2
-	x	-	x		HP	O	H3
-	x	-	x	x	HP	B	H3
-			x		HP	O	EH
-			x	-	HP	B	EH
-	-	-	x	x	HP	O	Invalid
-	x	-	x	-	HC	-	Invalid
-	x	-	-	x	HC	-	Invalid
-	-	x	x	-	HC	-	Invalid
-	-	x	-	x	HC	-	Invalid
-	x	x	x		HP	B	Invalid

NOTE: The maximum number of DXM controls with daisy-chained "ESD" terminals is 75. Also, the maximum total wire resistance of the "ESD" wiring is 500 ohms.

OVR - OVR is the input for Night Setback Override or Night Low Limit Staged Heating input (NLL). When Digital NSB is NOT selected via the Accessory relays dip switch inputs and NSB is connected to Ground "C", then if OVR is momentarily connected to 24Vac (minimum 1 second) then the OVR input is recognized as a Night Setback Override signal and the DXM control reverts from Night Setback and begins monitoring thermostat inputs for heating and cooling calls for a 2 hour override period. If NSB is connected to ground "C", then if OVR is continuously connected to 24V AC, then the OVR input is recognized as a call for NLL staged heating and the control enters NLL staged heating.

H - The H input function is determined by the setting of dip2.7. If dip2.7=on then the H input is defined as Automatic Dehumidification Mode and is used as an "automatic" counterpart to dip1.5, meaning if H is connected to 24Vac then the Fan Speed Relay will not turn on during Cooling Stage 2. If H is not connected to 24Vac then the Fan Speed Relay will turn on during Cooling Stage 2.

If dip2.7=off then the H input is defined as High Speed Fan input and is used as an input to call for High Speed Fan. If the control is in normal operating modes such as Standby, Cooling or Heating AND the H input is connected to 24Vac, then the Fan Enable and Fan Speed relays will be on at all times (this operation is very similar to the G/Fan Enable operation).

Table 5. System Inputs with the resulting demand. Table 5 describes demand changes with differing system input (ESD, NSB, OVR) and DIP input settings. Resulting Demand #1 is derived from Table 4

Resulting Demand #1 (From Table 4)	System Inputs			NSB Type	Resulting Demand #2 (After ESD, NSB)
	ESD	NSB	OVR		
-	x	-	-	-	ESD
Invalid	-	-	-	-	Invalid
All (excluding Invalid)				-	All (excluding Invalid)
All (excluding Invalid)			M	-	All (excluding Invalid)
C1, C2			x	-	Invalid
Off, F, H1, H2, or H3			x	-	NLL Staged Heating
EH			x	-	EH
All (excluding Invalid)		x		Mechanical	Standby/Off
All (excluding Invalid)		x	M	Mechanical	All for 2 hrs and then revert to Standby/Off (excluding Invalid)
C1, C2		x	x	Mechanical	Invalid
Off, F, H1, H2, or H3		x	x	Mechanical	NLL Staged Heating
EH		x	x	Mechanical	EH
All (excluding Invalid)		x		Digital	All (excluding Invalid)
All (excluding Invalid)		x	M	Digital	All (excluding Invalid)
C1, C2		x	x	Digital	Invalid
Off, F, H1, H2, or H3		x	x	Digital	NLL Staged Heating
EH		x	x	Digital	EH

"M" is momentary input
 "X" is continuous input

Table 6. "H" input with resulting demand modes. Table 6 describes demand changes with "H" input and DIP 2.1-2.3, and 2.7 settings. Resulting Demand #2 is derived from Table 5

Resulting Demand #2 (From Table 5)	H	Auto Dehum / F2 Dip 2.7	Resulting Demand #3 (After DIP 2.1-2.3, 2.7 Logic)
Standby/Off	x	Auto Dehum Mode	Standby/Off with Auto Dehum enabled
Standby/Off	x	High Fan Mode	F2
F1	x	Auto Dehum Mode	F1 with Auto Dehum enabled
F1	x	High Fan Mode	F2
C1	x	Auto Dehum Mode	C1 with fan destage
C1	x	High Fan Mode	*Clg with High Fan
C2	x	Auto Dehum Mode	C2 with fan destage
C2	x	High Fan Mode	*Clg with High Fan
H1	x	Auto Dehum Mode	H1
H1	x	High Fan Mode	Htg with High Fan
H2	x	-	H2
H3	x	-	H3
EH	x	-	EH
Invalid	-	-	Invalid

* = signifies that High Fan is locked on regardless of any Dehum demands.

Other Outputs

Table 10 displays input and output signals.

Electric Heat

Outputs EH1 and EH2 turn on whenever the DXM control is in the following modes: Heating Stage 3, Emergency Heat, and boilerless operation.

Status LED

The Status LED is green. The Status LED indicates what mode the DXM control is in. See Table 3: “LED and Alarm Relay Operation”.

Test LED

The Test LED is yellow. The Test LED will be on any time the control is in Test mode. See Table 3: “LED and Alarm Relay Operation”.

Fault LED

The Fault LED is red. The Fault LED ALWAYS flashes the corresponding code for the last fault that has occurred. If there is no fault in memory, then the fault LED will flash Code 1. If the Fault type is “Primary” (HP, LP, FP1, FP2, or CO) then the Fault type will always be retained in memory (Primary faults will overwrite Secondary faults). If the Fault type is “Secondary” (Over/Under Voltage or UPS) then the Fault type will only be retained if there are no “Primary” faults in memory. The Secondary Fault types will not “overwrite” the Primary fault memory. See Table 3: “LED and Alarm Relay Operation”.

Communications

There are two communications ports (Com1 and Com2) which provide robust communications to external DXM control boards via a simple noise resistant low speed protocol. Wiring to Com1 and Com2 does NOT require the use of shielded wiring for operation; standard thermostat wire can be used.

Com1

Com1 is used to communicate thermostat and external calls to other DXM Master/Slave controls. In this configuration, up to 3 heat pumps can be controlled by one thermostat.

Note: Each heat pump could potentially be a Dual Compressor unit thus there could be up to 6 DXM controls being controlled by one thermostat. However, only 1 DXM control in each heat pump will be daisy-chained on Com1. See schematic on page 15.

The Master DXM control is defined as the DXM control, which is directly connected to the wall-mounted thermostat, time clock, fire alarm, and humidistat. The Master DXM communicates to the Slave DXM typical signals such as: Y1, Y2, W1, O/W2, G, NSB, ESD, OVR, and H. The Slave DXM controls should have no direct connections to any exterior devices such as thermostats, time clocks, fire alarms, humidistats, etc...

Com2

Com2 is used to communicate thermostat and external calls to a second DXM control being used for Dual Compressor Function. A heat pump with two compressors will have a DXM control for each compressor. The Master DXM control will handle all I/O with external sources as well as monitor and control operations of the Secondary DXM control. The Master DXM control is defined as the DXM control, which is directly connected to the wall-mounted thermostat, time-clock, fire alarm, and humidistat. The Master DXM communicates to the Secondary DXM typical signals such as: Y1, Y2, W1, O/W2, G, NSB, ESD, OVR, and H. The Secondary DXM control should have no connections to any exterior devices such as thermostats, time clocks, fire alarms, humidistats, etc...

Since the Master and Secondary DXM controls share CO sensor and water valve/pump restart operations, these 2 signals are shared via communications as well. If either the Master or Secondary DXM control senses a CO fault, both DXM controls will fault and/or lockout due to the CO signal. Regarding water valve/pump restart control, if either the Master or Secondary DXM control faults or goes into lockout mode, it will continue to provide water valve/pump restart operation for the other functioning DXM control.

Typical DXM Wiring Schematic 208-230/60/1

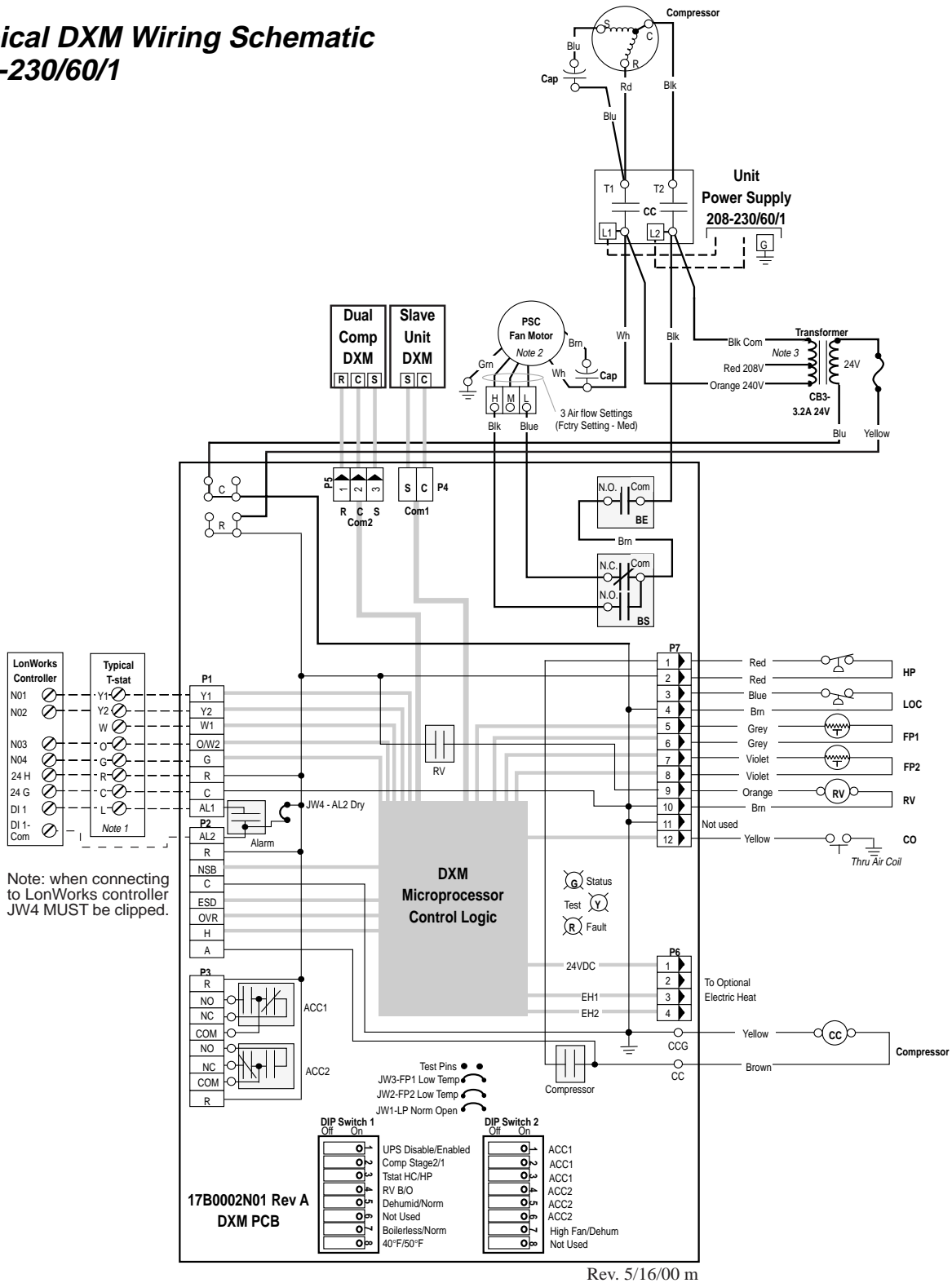

Legend			

Notes:
 1 - Check installation wiring information for specific thermostat hookup instructions.
 2 - Shown with optional two speed fan control
 3 - On 208/230V units, switch orange and red wires for 208V operation

Product Design and Application Notes

Sensors

Pressure Switches-

All pressure switches are designed to be normally closed during normal operating conditions, and to open upon fault.

Condensate Sensor-

The condensate sensor input will fault upon sensing impedance less than 100,000 ohms for 30 continuous seconds. The recommended design uses a single wire terminated with a male 1/4" quick connect located in the drain pan at desired trip level. Upon a high condensate level the water will short between the air coil and the quick connect producing a resistance less than 100,000 ohms. Since condensate is free of impurities, it has no conductivity. Only the impurities from the drain pan and coil dust or dirt create the conductance. A second ground wire with appropriate terminal to the drain pan can be used with the control to replace the air coil ground path. The condensate sensor can also essentially be any open contact that closes upon a fault condition.

Thermistor Temperature Sensors-

The thermistor is available in the following configurations shown in Table 7. The thermistor is an NTC (negative temperature coefficient) type. The sensor has a 1% tolerance and follows the Table 8 and Chart 1 shown. Table 9 shows the nominal resistance at any given temperature and can be used for field service reference. The sensor will use a minimum of 24 awg wire and be epoxy embedded in the beryllium copper clip.

Table 8. 1% Sensor Calibration Points

Temp (°F)	Minimum Resistance (ohm)	Maximum Resistance (ohm)	Nominal Resistance (ohm)
78.5	9523	9715	9619
77.5	9650	9843	9746
76.5	10035	10236	10135
75.5	10282	10489	10385
33.5	30975	31598	31285
32.5	31871	32512	32190
31.5	32653	33310	32980
30.5	33728	34406	34065
1.5	80624	82244	81430
0.5	83327	85002	84160
0.0	84564	86264	85410

Chart 1. Thermistor Nominal Resistance

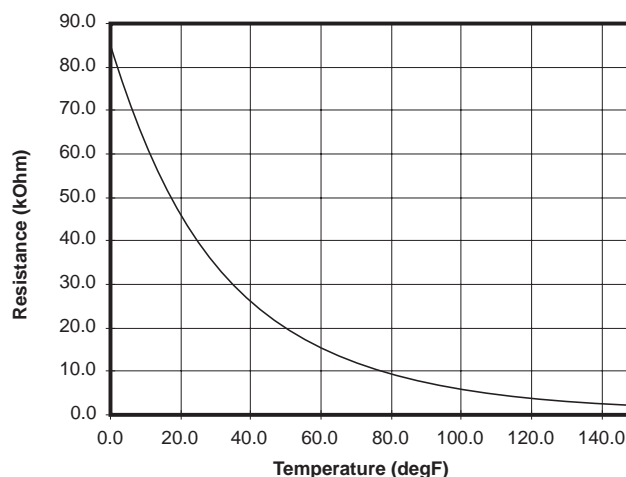

Table 7. Replacement Thermistor FP1, FP2 Part Numbers

Thermistor Type	Tube OD	Lead Length In.			
		36	48	96	192
FP1 (Gray)	3/8, 1/2	17B0005N06	N/A	17B0005N04	N/A
	5/8, 7/8	N/A	N/A	17B0004N01	N/A
FP2 (Violet)	3/8, 1/2	N/A	17B0005N02	N/A	17B0005N05
	5/8, 7/8	N/A	N/A	N/A	17B0004N02

Rev. 5/17/00 m

Table 9. Nominal resistance at various temperatures

Temp (°C)	Temp (°F)	Resistance (kOhm)	Temp (°C)	Temp(°F)	Resistance (kOhm)
-17.8	0.0	85.41	55	131.0	2.99
-17.5	0.5	84.16	56	132.8	2.88
-16.9	1.5	81.43	57	134.6	2.77
-12	10.4	61.70	58	136.4	2.67
-11	12.2	58.40	59	138.2	2.58
-10	14.0	55.30	60	140.0	2.49
-9	15.8	52.40	61	141.8	2.40
-8	17.6	49.60	62	143.6	2.32
-7	19.4	47.00	63	145.4	2.23
-6	21.2	44.60	64	147.2	2.16
-5	23.0	42.30	65	149.0	2.08
-4	24.8	40.10	66	150.8	2.01
-3	26.6	38.10	67	152.6	1.94
-2	28.4	36.10	68	154.4	1.88
-1	30.2	34.30	69	156.2	1.81
0	32.0	32.60	70	158.0	1.75
1	33.8	31.00	71	159.8	1.69
2	35.6	29.40	72	161.6	1.64
3	37.4	28.00	73	163.4	1.58
4	39.2	26.60	74	165.2	1.53
5	41.0	25.30	75	167.0	1.48
6	42.8	24.10	76	168.8	1.43
7	44.6	23.00	77	170.6	1.38
8	46.4	21.90	78	172.4	1.34
9	48.2	20.80	79	174.2	1.30
10	50.0	19.90	80	176.0	1.26
11	51.8	18.97	81	177.8	1.22
12	53.6	18.09	82	179.6	1.18
13	55.4	17.25	83	181.4	1.14
14	57.2	16.46	84	183.2	1.10
15	59.0	15.71	85	185.0	1.07
16	60.8	15.00	86	186.8	1.04
17	62.6	14.32	87	188.6	1.00
18	64.4	13.68	88	190.4	0.97
19	66.2	13.07	89	192.2	0.94
20	68.0	12.49	90	194.0	0.92
21	69.8	11.94	91	195.8	0.89
22	71.6	11.42	92	197.6	0.86
23	73.4	10.92	93	199.4	0.84
24	75.2	10.45	94	201.2	0.81
25	77.0	10.00	95	203.0	0.79
26	78.8	9.57	96	204.8	0.76
27	80.6	9.17	97	206.6	0.74
28	82.4	8.78	98	208.4	0.72
29	84.2	8.41	99	210.2	0.70
30	86.0	8.06	100	212.0	0.68
31	87.8	7.72	101	213.8	0.66
32	89.6	7.40	102	215.6	0.64
33	91.4	7.10	103	217.4	0.62
34	93.2	6.81	104	219.2	0.60
35	95.0	6.53	105	221.0	0.59
36	96.8	6.27	106	222.8	0.57
37	98.6	6.02	107	224.6	0.56
38	100.4	5.78	108	226.4	0.54
39	102.2	5.55	109	228.2	0.53
40	104.0	5.33	110	230.0	0.51
41	105.8	5.12	111	231.8	0.50
42	107.6	4.92	112	233.6	0.48
43	109.4	4.73	113	235.4	0.47
44	111.2	4.54	114	237.2	0.46
45	113.0	4.37	115	239.0	0.45
46	114.8	4.20	116	240.8	0.43
47	116.6	4.04	117	242.6	0.42
48	118.4	3.89	118	244.4	0.41
49	120.2	3.74	119	246.2	0.40
50	122.0	3.60	120	248.0	0.39
51	123.8	3.47	121	249.8	0.38
52	125.6	3.34	122	251.6	0.37
53	127.4	3.22	123	253.4	0.36
54	129.2	3.10			

Rev.: 5/23/00 m

Thermostat Details

Thermostat Compatibility -

Most all heat pump and heat/cool thermostats can be used with the DXM control.

Anticipation Leakage Current -

Maximum leakage current for "Y" is 50mA and for "W" is 20mA. Triacs can be used if leakage current is less than above. Thermostats with anticipators can be used if anticipation current is less than that specified above.

Thermostat Signals -

- "Y1, Y2, W1, O/W2" and "G" have a 1 second recognition time when being activated or being removed.
- "R" and "C" are from the transformer.
- "AL1" and "AL2" originate from the alarm relay.
- "A" is paralleled with the compressor output for use with well water solenoid valves.

Safety Listing

The control is listed under the UL 353 standard for Limit Controls. A comparable listing is pending for CE at the time of publishing.

Troubleshooting Information

General

DXM board troubleshooting in general is best summarized as simply verifying inputs and outputs. After this process has been verified, confidence in board operation is confirmed and the trouble must be elsewhere. Below are some general guidelines required for developing training materials and procedures when applying the DXM control.

Field Inputs

All inputs are 24VAC from the thermostat and can be verified using a volt meter between C and Y1, Y2, W, O/W2 and G. See the I/O Reference table below.

Sensor Inputs

All sensor inputs are 'paired wires' connecting each component with the board. Therefore continuity on pressure switches, and the condensate switch can be checked at the board connector.

The thermistor resistance should be measured with the connector removed so that only the impedance of the thermistor is measured. If desired this reading can be

compared to the chart shown in the thermistor section of this manual based upon the actual temperature of the thermistor clip. An ice bath can be used to check calibration of a thermistor if needed.

Outputs

The compressor relay is 24VAC and can be verified using a voltmeter. The alarm relay can either be 24VAC as shipped or dry contacts (measure continuity during fault) for use with DDC by clipping the J4 jumper. Electric heat outputs are 24VDC and require a voltmeter set for DC to verify operation. When troubleshooting, measure from 24VDC terminal to EH1 or EH2 terminals. See the I/O Reference table below.

Test Mode

Test mode can be entered for 20 minutes by shorting the test pins. For Diagnostic ease at the thermostat, the alarm relay will also cycle during test mode. The Alarm relay will cycle on and off similar to the fault LED to indicate a code representing the last fault, at the thermostat. Test mode can also be entered and exited by cycling the G input, 3 times within a 60 second time period.

Table 10. Input/Output Reference Table

Connection	Input or Output	Description
R	-	24 VAC
C	-	24 VAC (grounded common)
Y1	I	Connect to thermostat - Y1 output call for compressor stage 1
Y2	I	Connect to thermostat - Y2 output call for compressor stage 2
W1	I	Connect to thermostat - W1 output call for Htg 3 or Emerg Ht
O/W2	I	Connect to thermostat - O output call for reversing valve with cooling
G	I	Connect to thermostat - G output call for fan
AL1	O	Connect to thermostat fault light - 24VAC or dry alarm
AL2	O	Alarm Relay 24VAC or dry
A	O	Output for water solenoid valve - paralleled with compressor contactor coil
Fan Enable	O	Fan enable relay
Fan Speed	O	Fan speed relay
CC	O	Connection for compressor contactor
CCG	O	Compressor contactor common connection
HP	I	High Pressure Switch input terminals
LP	I	Low Pressure Switch input terminals
FP1	I	Water Coil Freeze Protection Thermistor Input
FP2	I	Air Coil Freeze Protection Thermistor Input
RV	O	Reversing Valve Output Terminals - direct connect from "O"
CO	I	Condensate overflow input terminals
24VDC	O	24 VDC supply to electric heat module
EH1	O	Output terminal for stage 1 electric heat
EH2	O	Output terminal for stage 2 electric heat
NSB	I	Night Setback input
OVR	I	Night Setback Over Ride Input
ESD	I	Emergency Shutdown Input
H	I	Dehumidification or High Speed Fan input (dip 2.7)

Troubleshooting Chart

Use the following troubleshooting flow chart to find appropriate troubleshooting strategies on the following pages for the DXM control and most water source heat pump applications.

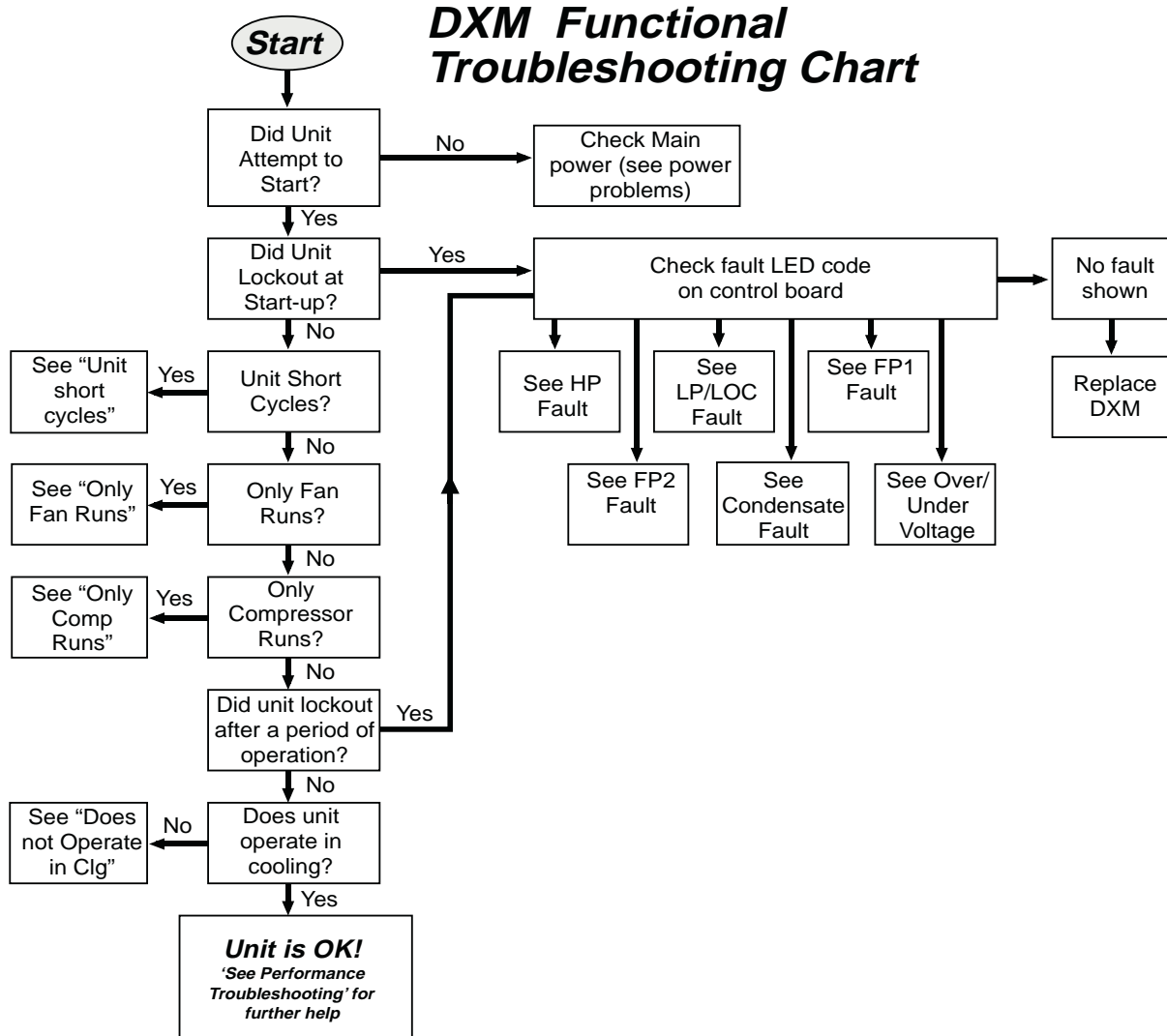

Functional Troubleshooting

Fault	Htg	Clg	Possible Cause	Solution
Main power Problems	X	X	Green Status LED Off	Check Line Voltage circuit breaker and disconnect Check for line voltage between L1 and L2 on the contactor Check for 24VAC between R and C on DXM Check primary/secondary voltage on transformer
		X	Reduced or no water flow in cooling	Check pump operation or valve operation/setting Check water flow adjust to proper flow rate
		X	Water Temperature out of range in cooling	Bring water temp within design parameters
		X	Reduced or no Air flow in heating	Check for dirty air filter and clean or replace Check fan motor operation and airflow restrictions Dirty Air Coil- construction dust etc. Too high of external static. Check static vs blower table
HP Fault-Code 2 High pressure	X		Air Temperature out of range in heating	Bring return air temp within design parameters
	X	X	Overcharged with refrigerant	Check superheat/subcooling vs typical operating condition table
	X	X	Bad HP Switch	Check switch continuity and operation. Replace
	X	X	Insufficient charge	Check for refrigerant leaks
	X		Compressor pump down at start-up	Check charge and start-up water flow
	X	X	Bad thermistor	Check temp and impedance correlation per chart
LP/LOC Fault-Code 3 Low Pressure/Loss of Charge	X	X	Insufficient charge	Check for refrigerant leaks
FP1 Fault - Code 4 Water freeze protection	X		Reduced or no water flow in heating	Check pump operation or water valve operation/setting Plugged strainer or filter. Clean or replace. Check water flow adjust to proper flow rate
	X		Inadequate anti-freeze level	Check antifreeze density with hydrometer
	X		Improper freeze protect setting (30°F vs 10°F)	Clip JW2 jumper for antifreeze (10°F) use
	X		Water Temperature out of range	Bring water temp within design parameters
	X	X	Bad thermistor	Check temp and impedance correlation per chart
	FP2 fault - Code 5 Air Coil freeze protection		X	Reduced or no Air flow in cooling
		X	Air Temperature out of range	Too much cold vent air? Bring entering air temp within design parameters
		X	Improper freeze protect setting (30°F vs 10°F)	Normal airside applications will require 30°F only
X		X	Bad thermistor	Check temp and impedance correlation per chart
Condensate Fault-Code 6	X	X	Blocked Drain	Check for blockage and clean drain
	X	X	Improper trap	Check trap dimensions and location ahead of vent
		X	Poor Drainage	Check for piping slope away from unit Check slope of unit toward outlet Poor venting. Check vent location
		X	Moisture on sensor	Check for moisture shorting to air coil
Over/Under Voltage-Code 7 (Auto resetting)	X	X	Under Voltage	Check power supply and 24VAC voltage before and during operation. Check power supply wire size Check compressor starting. Need hard start kit? Check 24VAC and unit transformer tap for correct power supply voltage
	X	X	Over Voltage	Check power supply voltage and 24VAC before and during operation. Check 24VAC and unit transformer tap for correct power supply voltage
Unit Performance Sentinel-Code 8	X		Heating mode FP2>125°F	Check for poor air flow or overcharged unit.
		X	Cooling Mode FP1>125°F OR FP2< 40°F	Check for poor water flow, or air flow
No Fault Code Shown	X	X	No compressor operation	See 'Only fan operates'
	X	X	Compressor Overload	Check and Replace if necessary
	X	X	Control board	Reset power and check operation
Unit Short Cycles	X	X	Dirty Air Filter	Check and Clean air filter
	X	X	Unit in 'Test Mode'	Reset power or wait 20 minutes for auto exit.
	X	X	Unit selection	Unit may be oversized for space. Check sizing for actual load of space.
	X	X	Compressor Overload	Check and Replace if necessary
Only Fan Runs	X	X	Thermostat position	Insure thermostat set for heating or cooling operation
	X	X	Unit locked out	Check for lockout codes. Reset power.
	X	X	Compressor Overload	Check compressor overload. Replace if necessary.
	X	X	Thermostat wiring	Check Y and W wiring at heat pump. Jumper Y and R for compressor operation in test mode.

Rev. 5/17/00 m

Functional Troubleshooting (cont.)

Only Compressor Runs	X	X	Thermostat wiring	Check G wiring at heat pump. Jumper G and R for fan operation.
	X	X	Fan motor relay	Jumper G and R for fan operation. Check for Line voltage across BR contacts. Check fan power enable relay operation (if present)
	X	X	Fan motor	Check for line voltage at motor. Check capacitor
	X	X	Thermostat wiring	Check Y and W wiring at heat pump. Jumper Y and R for compressor operation in test mode.
Unit Doesn't Operate in Cooling		X	Reversing Valve	Set for cooling demand and check 24VAC on RV coil and at DXM board. If RV is stuck, run high pressure up by reducing water flow and while operating engage and disengage RV coil voltage to push valve.
		X	Thermostat setup	Check for 'O' RV setup not 'B'
		X	Thermostat wiring	Check O wiring at heat pump. Jumper O and R for RV coil 'Click'.

Performance Troubleshooting

Performance Troubleshooting	Htg	Clg	Possible Cause	Solution	
Insufficient capacity/ Not cooling or heating properly	X	X	Dirty Filter	Replace or clean	
	X		Reduced or no Air flow in heating	Check for dirty air filter and clean or replace Check fan motor operation and airflow restrictions Too high of external static. Check static vs blower table	
		X	Reduced or no Air flow in cooling	Check for dirty air filter and clean or replace Check fan motor operation and airflow restrictions Too high of external static. Check static vs blower table	
	X	X	Leaky duct work	Check supply and return air temperatures at the unit and at distant duct registers if significantly different, duct leaks are present	
	X	X	Low refrigerant charge	Check superheat and subcooling per chart	
	X	X	Restricted metering device	Check superheat and subcooling per chart. Replace.	
		X	Defective Reversing Valve	Perform RV touch test	
	X	X	Thermostat improperly located	Check location and for air drafts behind stat	
	X	X	Unit undersized	Recheck loads & sizing check sensible clg load and heat pump capacity	
	X	X	Scaling in water heat exchanger	Perform Scaling check and clean if necessary	
High Head Pressure	X		Reduced or no Air flow in heating	Check for dirty air filter and clean or replace Check fan motor operation and airflow restrictions Too high of external static. Check static vs blower table	
		X	Reduced or no water flow in cooling	Check pump operation or valve operation/setting Check water flow adjust to proper flow rate	
		X	Inlet Water too Hot	Check load, loop sizing, loop backfill, ground moisture.	
	X		Air Temperature out of range in heating	Bring return air temp within design parameters	
		X	Scaling in water heat exchanger	Perform Scaling check and clean if necessary	
	X	X	Unit Overcharged	Check superheat and subcooling. Reweigh in charge	
	X	X	Non-condensables in system	Vacuum system and reweigh in charge	
	X	X	Restricted metering device	Check superheat and subcooling per chart. Replace.	
	Low Suction Pressure	X		Reduced water flow in heating	Check pump operation or water valve operation/setting Plugged strainer or filter. Clean or replace. Check water flow adjust to proper flow rate
		X		Water Temperature out of range	Bring water temp within design parameters
		X	Reduced Air flow in cooling	Check for dirty air filter and clean or replace Check fan motor operation and airflow restrictions Too high of external static. Check static vs blower table	
		X	Air Temperature out of range	Too much cold vent air? Bring entering air temp within design parameters	
X		X	Insufficient charge	Check for refrigerant leaks	
Low discharge air temperature in heating	X		Too high of air flow	Check fan motor speed selection and airflow chart	
	X		Poor Performance	See 'Insufficient Capacity'	
High humidity		X	Too high of air flow	Check fan motor speed selection and airflow chart	
		X	Unit oversized	Recheck loads & sizing check sensible clg load and heat pump capacity	

Rev. 5/17/00 m



Part #: 97B0003N02



7300 S.W. 44th Street
Oklahoma City, OK 73179
Phone: 405-745-6000
Fax: 405-745-6058
www.climatemaster.com

ClimateMaster works continually to improve its products. As a result, the design and specifications of each product at the time of order may be changed without notice and may not be as described herein. Please contact ClimateMaster's Customer Service Department at 1-405-745-6000 for specific information on the current design and specifications. Statements and other information contained herein are not express warranties and do not form the basis of any bargain between the parties, but are merely ClimateMaster's opinion or commendation of its products.