

TABLE OF CONTENTS

	Page
General Information	3
Inspection	3
Introduction	3
Storage	3
Unit Protection	3
Pre-Installation	3
Horizontal Units Location and Access	4
Vertical Units location and Access	5
Installation	6
Installation of Supply and Return Piping	6
Condensate Piping	6
Hanging and Mounting a Horizontal Unit	7
Sound Attenuation for Horizontal Units	7
Installing a Vertical Unit	8
Sound Attenuation for Vertical Units	8
Electrical Wiring	8
Operating Limits	9
Starting Conditions	9
Closed Loop Earth Coupled Applications	10
Introduction	10
Pre-Installation	10
Horizontal Loop Applications	10
Vertical Loop Applications	10
Building Entry	11
Loop Testing	12
Flushing and Purging	12
Start-Up Preparation	13
System Cleaning & Flushing	13
Optional Hot Water Generator	13
System Checkout	14
Unit Start-Up	15
Maintenance	16

GENERAL INFORMATION

Inspection

Upon receipt of shipment at the job site, carefully check the shipment against the bill of lading. Make sure all units have been received. Verify that hanger brackets are located inside the fan compartment of Horizontal Units. Inspect the carton or crating of each unit and inspect each unit for damage. Repackage unit after verifying that all components are included. Assure that the carrier makes proper notation of any shortages or damage on all copies of the freight bill and that he completes a Carrier Inspection Report. Concealed damage not discovered during unloading must be reported to the carrier within 15 days of receipt of shipment. **NOTE: It is the responsibility of the purchaser to file all necessary claims with the carrier. Notify the ClimateMaster Traffic Department of all damage within fifteen (15) days of shipment.**

Introduction

This Installation, Operation, and Maintenance Manual is for ClimateMaster low temperature extended range Horizontal and Vertical Heat Pumps (HE, VE), ClimateMaster Horizontal Water Source Heat Pump (HE) units are designed for installation above a false ceiling, ceiling plenum, crawl space, or basement. Vertical (VE) units are typically installed in a floor level closet or in a small mechanical room. The installation site chosen for these units must allow adequate clearance for maintenance and servicing of the unit without its removal from the installation location.

Electrical data is provided in the *Installation* section of this manual. Refer to project submittal drawings for specific unit technical data and wiring diagrams.

Storage

⚠ CAUTION

Do not store or install Horizontal or Vertical units in corrosive environments or in locations subject to temperature or humidity extremes (e.g., attics, garages, rooftops, etc.). Corrosive conditions and high temperature or humidity can significantly reduce performance, reliability and service life. Always move units in an upright position. Tilting units on their sides may cause equipment damage.

Upon the arrival of equipment at the job site, immediately store units in their shipping cartons in a clean, dry area. **Store units in an upright position at all times.** Stack Horizontal units a maximum of 3 units high. Stack vertical units a maximum of 2 units high. **Do not remove equipment from shipping cartons until equipment is required for installation.**

Unit Protection

Cover Horizontal and Vertical units on the job site with either shipping cartons, vinyl film, or an equivalent protective covering. Cap the open ends of pipes stored on the job site. In areas where painting, plastering, or the spraying of fireproof material has not been completed, all due precautions must be taken to avoid physical damage to the units and contamination by foreign material. Physical damage and contamination may prevent proper start-up and may result in costly equipment clean-up.

Examine all pipes, fittings, and valves before installing any of the system components. Remove any dirt found on these components.

Pre-Installation

Installation, Operation, and Maintenance instructions are provided with each unit. Before unit start-up, read all manuals and become familiar with the unit and its operation. Thoroughly check out the system before operation.

Prepare Horizontal and Vertical units for installation as follows:

1. Compare the electrical data on the unit nameplate with ordering and shipping information to verify that the correct unit has been shipped.
2. Keep the unit covered with the shipping carton until installation is complete and all plastering, painting, etc. is finished.
3. Verify that refrigerant tubing is free of kinks or dents and that it does not touch other unit components.
4. Inspect all electrical connections. Connections must be clean and tight at the terminals.
5. Loosen compressor bolts on units equipped with external spring vibration isolation until the compressor rides freely on the springs. Remove shipping restraints.

⚠ WARNING

To avoid equipment damage, do not use these units as a source of heating or cooling during the construction process. The mechanical components and filters used in these units quickly become clogged with construction dirt and debris which may cause system damage.

To avoid the release of refrigerant into the atmosphere, the refrigerant circuit of this unit must only be serviced by technicians which meet local, state and federal proficiency requirements.

⚠ WARNING

All refrigerant discharged from this unit must be recovered without exception. Technicians must follow industry accepted guidelines and all local, state and federal statutes for the recovery and disposal of refrigerants.

When a compressor is removed from this unit, system refrigerant circuit oil will remain in the compressor. To avoid leakage of compressor oil, the refrigerant lines of the compressor must be sealed after it is removed.

Horizontal Units Location and Access

Horizontal Units are typically installed above a false ceiling or in a ceiling plenum. Refer to Figure 1 below for an illustration of a typical installation. Install units with adequate clearance to allow maintenance and servicing without removal of the unit from the ceiling. Conform to the following guidelines when selecting unit location.

1. Provide a hinged access door in concealed-spline or plaster ceilings. Provide removable ceiling tiles in T-bar or lay-in ceilings. Size the access opening to accommodate the service technician during the removal and replacement of the compressor and the removal and installation of the unit.
2. Provide access to hanger brackets, water valves, and fittings. Provide screwdriver clearance to access panels, discharge collars, and all electrical connections.

Figure 1 - Typical Horizontal Installation

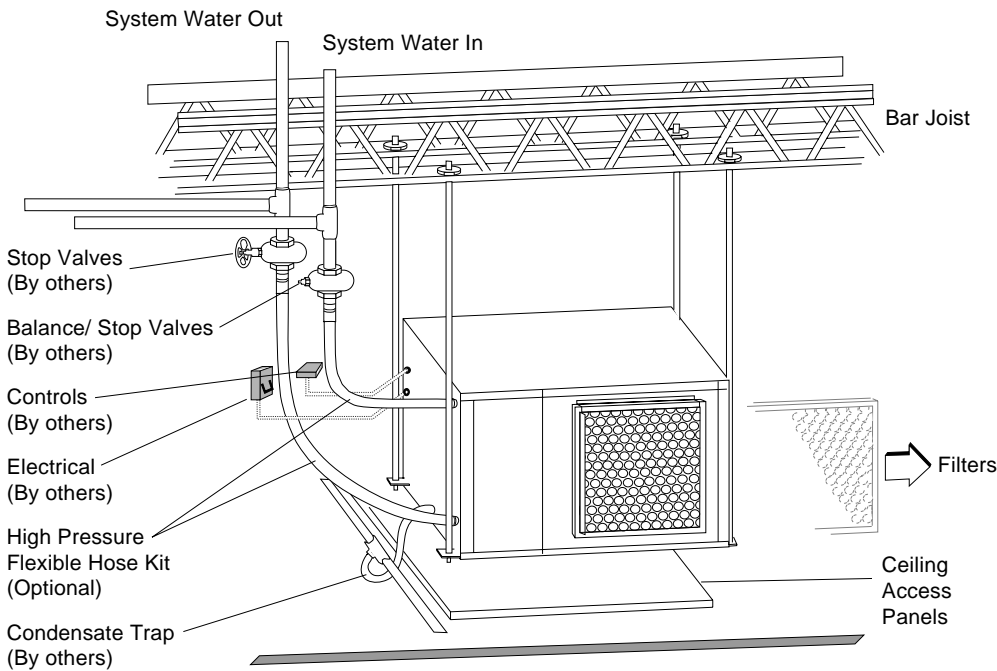
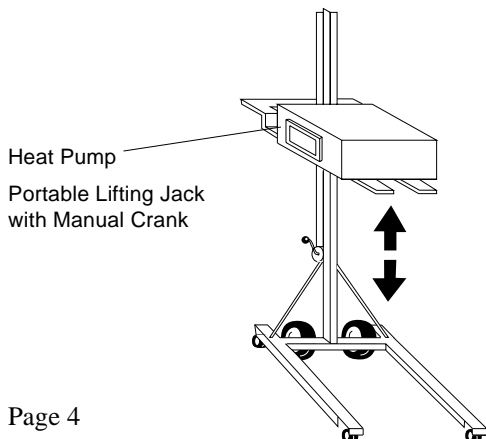

Figure 2 - Unit supported by Portable Jack during installation or replacement



3. Provide a duct slot for filter replacement if a return duct is used.
4. Do not obstruct the space beneath the unit with piping, electrical cables, and other items.
5. Refer to Figure 2. Use a manual portable jack to lift the unit and to support the weight of the unit during installation and servicing.

Vertical Units Location and Access

Vertical units are typically installed in a floor level closet or in a small mechanical room. Refer to Figure 3 for an illustration of a typical installation. Install units with adequate clearance to allow maintenance and servicing.

Conform to the following guidelines when selecting unit location.

1. Provide adequate clearance for filter replacement and drain pan cleaning. Do not block filter access with piping, conduit, or other materials.
2. Provide access for fan and fan motor maintenance and for servicing the compressors and coils without removal of the unit.
3. Provide an unobstructed path to the unit within the closet or mechanical room to enable removal of the unit if necessary.
4. Provide access to water valves and fittings, and screwdriver access to the unit side panels, discharge collar, and all electrical connections.

Figure 3 - Vertical Installation

Note: Adequate clearance must be provided on all sides of unit when remote filter/grille is not used

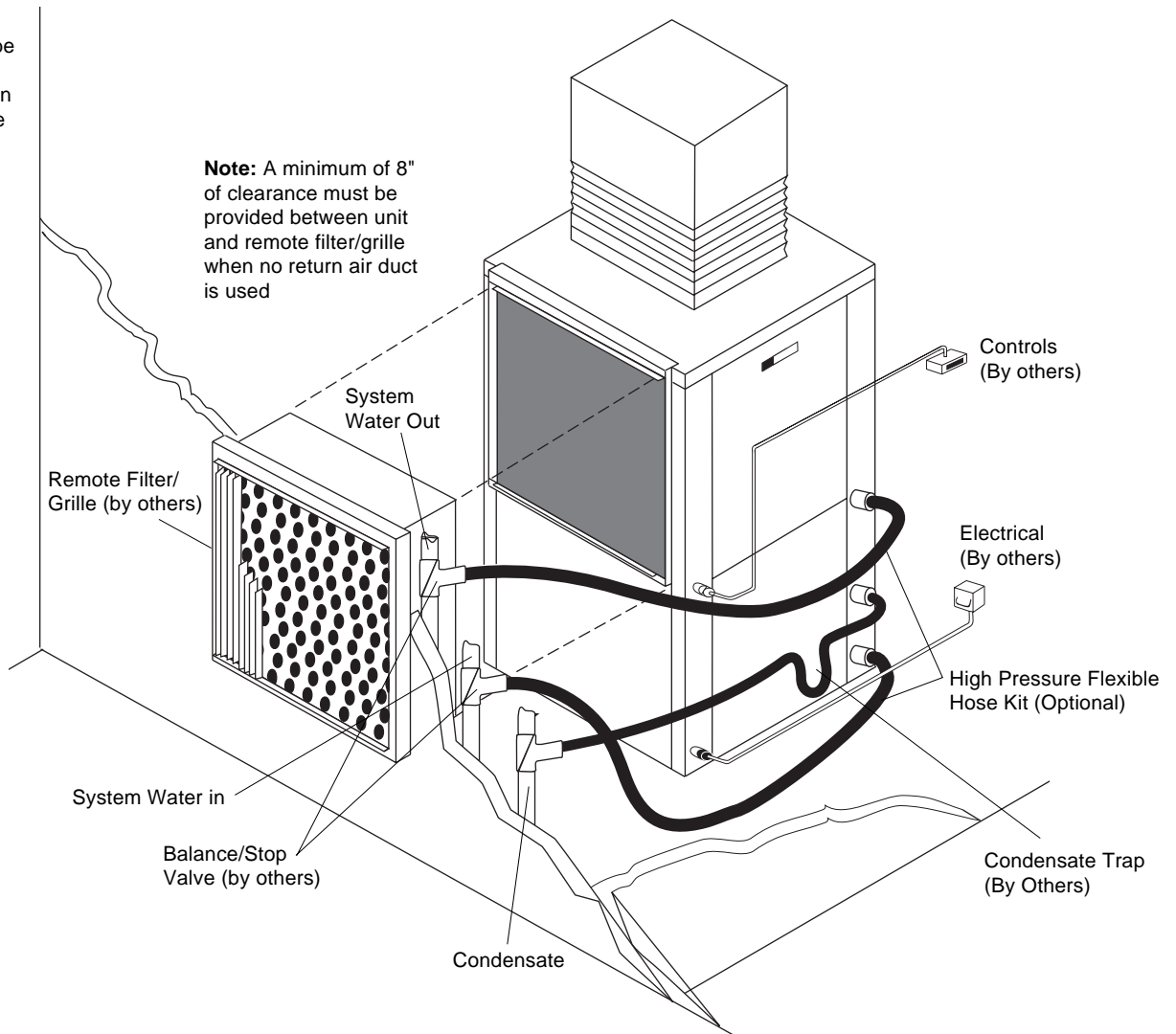

INSTALLATION

The installation of Horizontal and Vertical Water Source Heat Pump units and all associated components, parts and accessories that make up the installation shall be in accordance with the regulations of ALL Authorities having jurisdiction and MUST conform to all applicable Codes. It is the responsibility of the Installing Contractor to determine and comply with ALL applicable Codes and Regulations.

Installation of Supply and Return Piping

Follow these piping guidelines.

⚠ CAUTION

Piping must comply with all applicable codes.

1. Install a drain valve at the base of each supply and return riser to facilitate system flushing.
2. Install shut-off / balancing valves and unions at each unit to permit unit removal for servicing.
3. Place strainers at the inlet of each system circulating pump.
4. Select the proper hose length to allow slack between connection points. Hoses may vary in length by +2% to -4% under pressure.
5. Refer to Table 3. Do not exceed the minimum bend radius for the hose selected. Exceeding the minimum bend radius may cause the hose to collapse which reduces water flow rate. Install an angle adapter to avoid sharp bends in the hose when the radius falls below the required minimum.

Table 1- Metal Hose Minimum Bend Radii

Hose in Inches	Minimum Bend Radius
1/2	2-1/2
3/4	4
1	5-1/2
1-1/4	6-3/4

Insulation is not required on loop water piping except where the piping runs through unheated areas or outside the building. Insulation is required if loop water temperature drops below the dew point.

Pipe joint compound is not necessary when Teflon threaded tape is pre-applied to hose assemblies or when flared-end connections are used. If pipe joint compound is preferred, use compound only in small amounts on the male pipe threads of the fitting adapters. Prevent sealant from reaching the flared surfaces of the joint.

NOTE: When anti-freeze is used in the loop, assure that it is compatible with Teflon tape or pipe joint compound used.

Maximum allowable torque for brass fittings is 30 foot-pounds. If a torque wrench is not available, tighten finger-tight plus one quarter turn. Tighten steel fittings as necessary.

⚠ WARNING

Do not bend or kink supply lines or hoses.

Optional pressure-rated hose assemblies designed specifically for use with ClimateMaster units are available. Similar hoses can be obtained from alternate suppliers. Supply and return hoses are fitted with swivel-joint fittings at one end to prevent kinking during installation.

Refer to Figure 4 for an illustration of a Supply/Return Hose Kit. Male adapters secure hose assemblies to the unit and risers. Install hose assemblies properly and check them regularly to avoid system failure, reduced service life, and possible damage to surrounding furniture and carpets.

Figure 4- Supply/Return Hose Kit

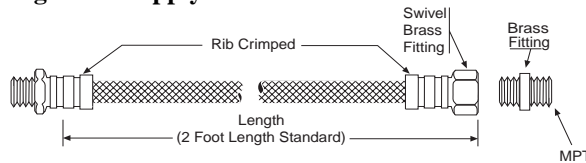

⚠ CAUTION

Corrosive system water requires corrosion-resistant fittings and hoses and may require water treatment.

Condensate Piping

Units are typically installed directly above each other on successive floors with condensate drains located near the units.

Connect the unit condensate drain connection to the building condensate drain with a flexible, non-pressure-rated 3/4 inch ID plastic hose. Ensure that the hose is without kinks to maintain an unobstructed flow of condensate from the unit to the drain.

The horizontal run of a condensate hose is usually too short to cause drainage problems; however, the horizontal run of the condensate line should be pitched at least 1 inch for every 10 feet of run in the direction of flow. Avoid low points and unpitched piping since dirt collects in low or level areas and may cause stoppage and overflow.

Install a condensate trap at each unit with the top of the trap positioned below the unit condensate drain connection.

Ensure that the trap is filled with water before operating the unit to avoid condensate pan overflow at initial start-up.

Figure 5 illustrates a typical trap and vent used with HE/VE Heat Pumps. Design the length of the trap (water-seal) based upon the amount of positive or

Figure 5 - Condensate Drain

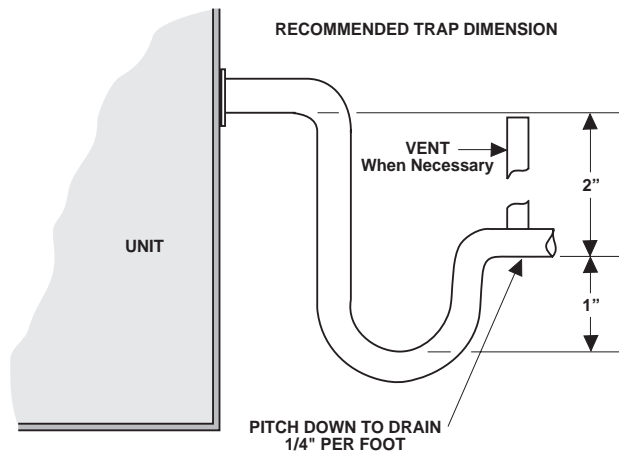

negative pressure on the drain pan. As a rule, 1" of trap is required for each inch of negative pressure on the unit.

Each unit must be installed with its own, individual trap and connection to the condensate line (main) or riser. Provide a means to flush or blow-out the condensate drain line. Do not install units with a common trap and/or vent.

Install a vent in the condensate line of any application which may allow dirt or air to collect in the line. Always vent when the application requires a long, horizontal run, when some sagging in the condensate line may be anticipated (as in a long line of plastic pipe), or when "double trapping" may occur. Also vent when large units are working against higher external static pressure that other units connected to the same condensate main since this may cause poor drainage for all units on the line. When a vent is installed in the condensate line, it must be located after the trap in the direction of condensate flow.

Hanging or Mounting a Horizontal Unit

Horizontal heat pumps are typically suspended above a ceiling or within a soffit using field-supplied, threaded rods sized to support the weight of the unit.

A mounting kit including four (4) mounting brackets and four (4) vibration isolators is shipped inside the blower compartment of each unit.

Refer to Figure 6. Attach brackets and isolators to the bottom corners of the unit. Use four (4) field-supplied threaded rods to suspend the unit. Hang the unit clear of the floor slab above and support the unit by the mounting bracket assemblies only. **DO NOT attach the unit flush with the floor slab above.**

Follow clearance guidelines described in the *Location and Access* section of this manual. Provide adequate clearance within the plenum for filter removal in all four directions. When the unit is installed with a return air plenum, provide a slot to remove the filter toward the front of the unit.

To avoid condensate overflow, Horizontal Units must be hung pitched 1/4" to 1/2" toward the condensate drain connection to insure proper drainage.

Figure 6 - Hanger and Vibration Isolation Kit

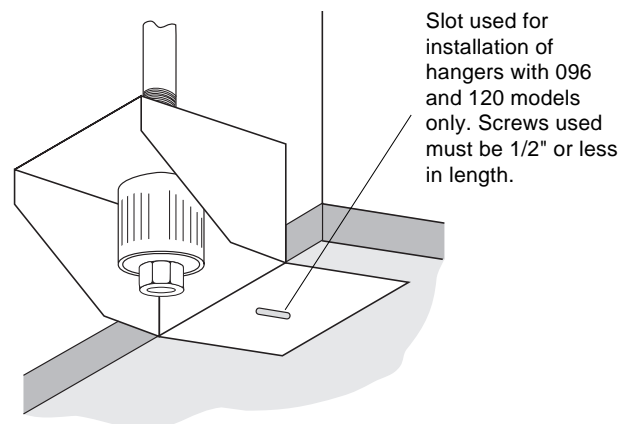
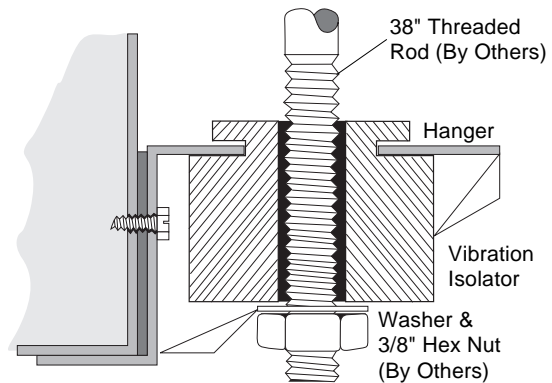

NOTES: 1. Kits shipped unassembled and bulk-packed (4 hanger assemblies per unit) 2. Total head space required = unit height + 1/2 inch + condensate trapping 3. See unit dimensional drawings for further information.

Sound Attenuation for Horizontal Units

Sound minimization is achieved by correct placement of the unit. Place the units so that principal sound emission is ducted outside the occupied, sound sensitive space.

Note: If a fire wall is penetrated, a fire damper may be required by local codes.

Installing a Vertical Unit

Vertical units are typically installed on the floor or on shelves designed to support the weight of the unit. Install the unit on a piece of rubber, neoprene or other mounting pad material for sound isolation. The pad should be at least 3/8" to 1/2" in thickness. Extend the pad beyond all four edges of unit.

Sound Attenuation for Vertical Units

Sound minimization is achieved by enclosing the unit within a small mechanical room or a closet. Additional measures for sound control include the following:

1. Mount the unit so that the return air inlet is 90° to the return air grille. Refer to Figure 7. Install a sound baffle as illustrated to reduce line-of-sight sound transmitted through return air grilles.
2. Mount the unit on a rubber or neoprene isomode pad to minimize vibration transmission to the building structure. Extend the pad beyond all four edges of the unit.

Figure 7 - Vertical Sound Attenuation

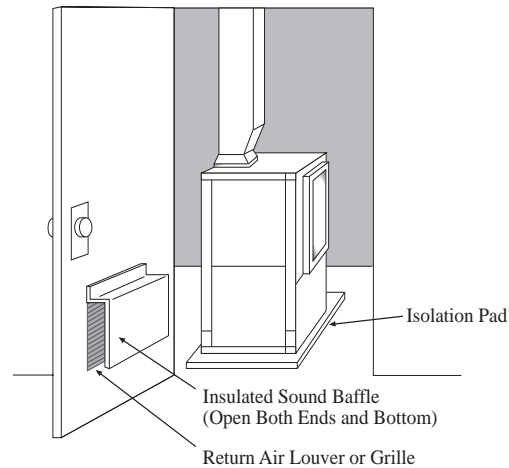

All field installed wiring, including electrical ground, must comply with the National Electrical Code (NEC) as well as all applicable local codes. In addition, all field wiring must conform to Class II temperature limitations described in the NEC.

Refer to the unit wiring diagrams included with submittal drawings for fuse sizes and a schematic of the field connections which must be made by the installing (or electrical) contractor.

Consult the unit wiring diagram located on the inside of the compressor access panel to ensure proper electrical hookup.

Units rated 208-230 volts that have a 24 volt transformer must have the transformer connection modified if the actual power supply is 230 volts. Refer to the unit wiring diagram for details of this procedure.

All final electrical connections must be made with a length of flexible conduit to minimize vibration and sound transmission to the building.

Electrical Wiring

⚠ WARNING ⚠

To avoid possible injury or death due to electrical shock, open the power supply disconnect switch and secure it in an open position during installation.

⚠ CAUTION

Use only copper conductors for field installed electrical wiring. Unit terminals are not designed to accept other types of conductors.

Typical Field Installed Wiring

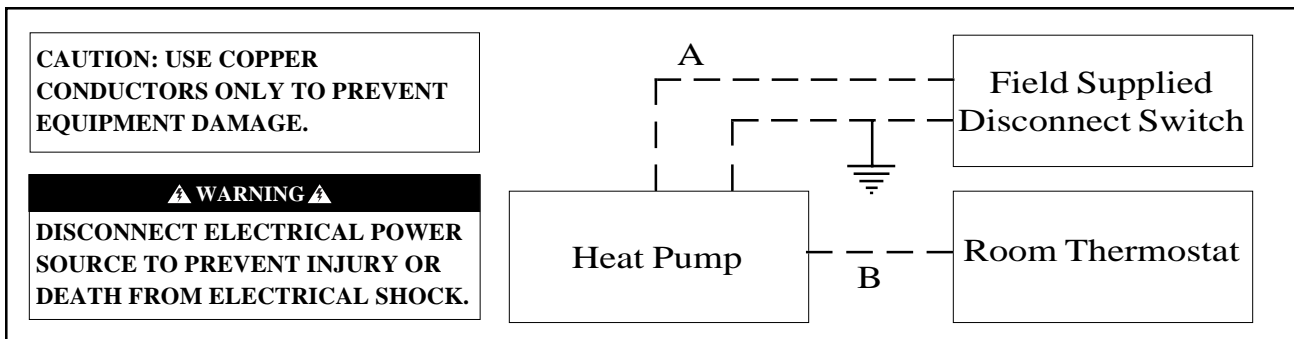

A= Two power wires on single-phase units; three power wires on three-phase units. B= 1 heat /1 cool /manual or Auto Change-Over remote 24V thermostat. Note: All customer-supplied wiring to be copper only and must conform to NEC and local electrical codes. Wiring shown with dashed lines must be field-supplied and field-installed.

Operating Limits

Environment - This unit is designed for **INDOOR INSTALLATION ONLY**.

Power Supply - A voltage variation of +/- 10% of nameplate utilization voltage is acceptable. Three-phase system imbalance shall not exceed 2%.

Starting Conditions

All Models - Units start and operate in an ambient of 40° F with entering air at 40° F with both air and water at the stated flow rates of ARI Standard 325 rating test for initial winter start-up.

NOTES

1. These are not normal or continuous operating conditions. This assumes a winter start-up to bring the building space up to occupancy temperatures.
2. Voltage utilization range complies with ARI Standard 110.

3. When using 100% outside air as a source of ventilation, a 40° F DB minimum and a 78° F WB maximum are acceptable, but the cabinet may sweat during hot weather.
4. Determination of operating limits is dependent primarily upon 3 factors: 1) return air temperature, 2) water temperature, and 3) ambient temperature. When any one of these factors is at minimum or maximum levels, the other two factors should be at normal levels to ensure proper unit operation.
5. Extreme variations in temperature and humidity, and corrosive water or air adversely affect unit performance, reliability, and service life.

Table 2 - Operating Limits

Air Limits	All Models	
	Cooling	Heating
Minimum Ambient Air	40° F	40° F
Rated Ambient Air	80° F	70° F
Maximum Ambient Air	100° F	85° F
Minimum Entering Air	50° F	40° F
Rated Entering Air db/wb	80/67° F	70° F
Maximum Entering Air db/wb	110/83° F	80° F
Water Limits		
Minimum Entering Water	40° F	25° F
Normal Entering Water	85° F	70° F
Maximum Entering Water	110° F	80° F

CLOSED LOOP EARTH COUPLED APPLICATIONS

Introduction

▲ CAUTION

The following instructions represent industry accepted installation practices for Closed Loop Earth Coupled Heat Pump Systems. They are provided to assist the contractor in installing trouble free ground loops. These instructions are recommendations only. State and Local Codes MUST be followed and installations MUST conform to ALL applicable Codes. It is the responsibility of the Installing Contractor to determine and comply with ALL applicable Codes and Regulations.

Closed Loop Earth Coupled Heat Pump systems are commonly installed in one of three configurations: horizontal, vertical, or pond loop. Each configuration provides the benefit of using the moderate temperature of the earth as a heat source/heat sink. Piping configurations can be either series or parallel.

Series piping configurations typically use 1-1/4", 1-1/2", or 2" pipe. Parallel piping configurations typically use 3/4" or 1" pipe for loops and 1-1/4", 1-1/2", or 2" pipe for headers and service lines. Parallel configurations require headers to be either "closed-coupled", short headers, or reverse return design.

Select the installation configuration which provides the most cost effective method of installation after considering all application constraints.

Refer to IGSHPA publication *Closed Loop/Ground Source Heat Pump Systems Installation Guide* (Sections 4-6) for complete ground loop design, materials requirements, and joining information.

Pre-Installation

Prior to installation, locate and mark all existing underground utilities, piping, etc. Install loops for new construction before sidewalks, patios, driveways, and other construction has begun. During construction, accurately mark all ground loop piping on the plot plan as an aid in avoiding potential future damage to the installation.

Horizontal Applications

To install Horizontal earth couplings, dig trenches using either a chain-type trenching machine or a backhoe. Dig trenches approximately 5 feet apart. Trenches must be at least 5 feet from existing utility lines, foundations, and property lines and at least 10 feet from wells. Trenches may be curved to avoid obstructions and may be turned around corners.

When multiple pipes are laid in a trench, space pipes properly and backfill carefully to avoid disturbing the spacing of the pipes in the trench.

Vertical Applications

To install Vertical earth couplings, drill boreholes using any size drilling equipment. Regulations which govern water well installations also apply to vertical ground loop installations. Vertical applications typically require multiple boreholes. Space boreholes a minimum of 10 feet apart.

Unless other requirements are mandated by code, use the following guideline when locating boreholes:

- 5 feet from foundations and lot lines
- 10 feet from utility lines and drain fields
- 20 feet from non-public wells
- 50 feet from public wells
- 100 feet from cesspools, feedlots, lagoons, seepage pits, and septic tanks.

The minimum diameter for 3/4" or 1" U-bend well bores is 4". Larger diameter boreholes may be drilled if convenient unless local code requires an expensive method of backfilling. Assemble each U-bend assembly, fill with water, and pressure test prior to insertion into the borehole.

To add weight and prevent the pipe from curving and digging into the borehole wall during insertion, tape a length of conduit, pipe, or reinforcing bar to the U-bend end of the assembly. This technique is particularly useful when inserting the assembly into a borehole filled with water or drilling mud solutions, since a water filled U-bend assembly is somewhat buoyant under these circumstances. Tape the pipes together approximately every 10 feet to prevent the assembly from separating under downward pressure and bowing out against the borehole wall.

Carefully backfill the boreholes to within 10 feet of the surface. Follow IGSHPA specifications for backfilling unless local codes mandate otherwise.

When all U-bends are installed, dig the header trench 4 to 6 feet deep and as close to the boreholes as possible. Use a spade to break through from ground level to the bottom of the trench. At the bottom of the trench, dig a relief to allow the pipe to bend for proper access to the header.

Building Entry

Seal and protect the entry point of the earth coupling into the building as shown in Figures 8-11 below.

Slab on Grade Construction

New Construction: When possible, position the pipe in the proper location prior to pouring the slab. To prevent wear as the pipe expands and contracts, protect the pipe with a layer of insulation as shown in Figure 8. When the slab is poured prior to installation, create a chase through the slab for the service lines with 4" PVC street elbows and sleeves. Refer to Section 4 of the IGSHPA manual for details.

Figure 8

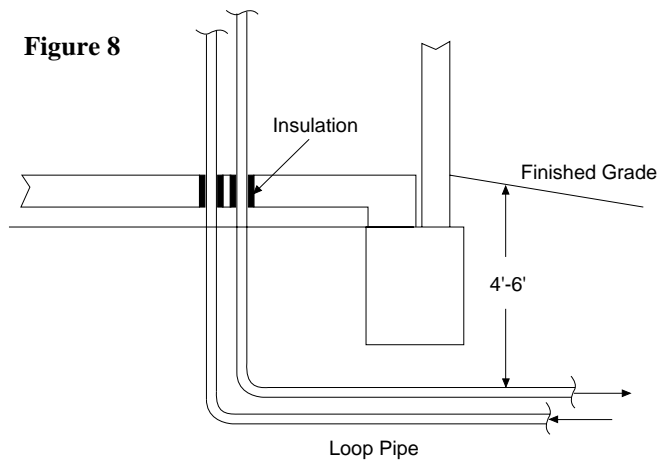

Retrofit Construction: Trench as close as possible to the footing. Bring the loop pipe up along the outside wall of the footing until it is higher than the slab. Enter the building as close to the slab as the construction allows. Shield and insulate the pipe to protect it from damage and the elements as shown in Figure 9.

Figure 9

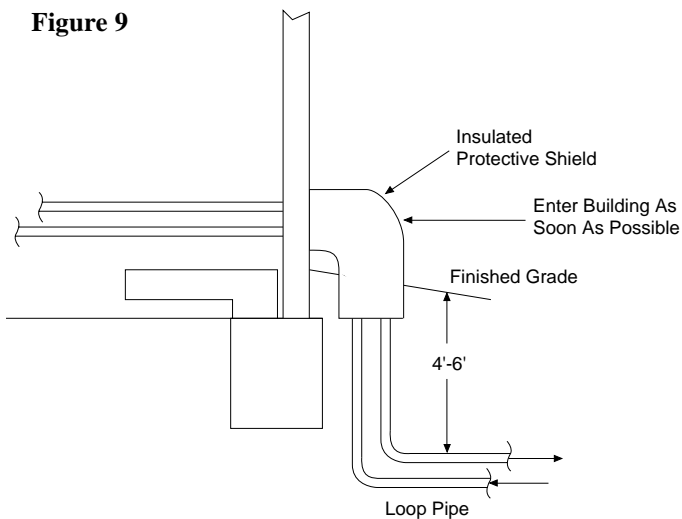

Pier and Beam (crawl space)

New and Retrofit Construction: Bury the pipe beneath the footing and between piers to the point that it is directly below the point of entry into the building. Bring the pipe up into the building. Shield and insulate piping as shown in Figure 10 to protect it from damage.

Figure 10

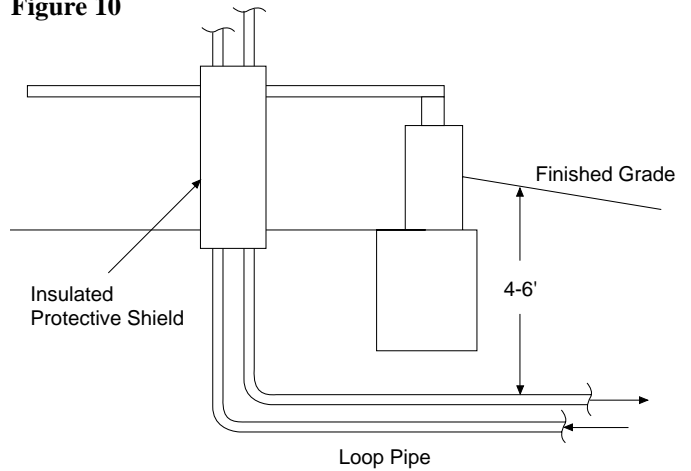

Below Grade Entry

New and Retrofit Construction: Bring the pipe through the wall as shown in Figure 11. For applications in which loop temperature may fall below freezing, insulate pipes at least 4 feet into the trench to prevent ice forming near the wall.

Figure 11

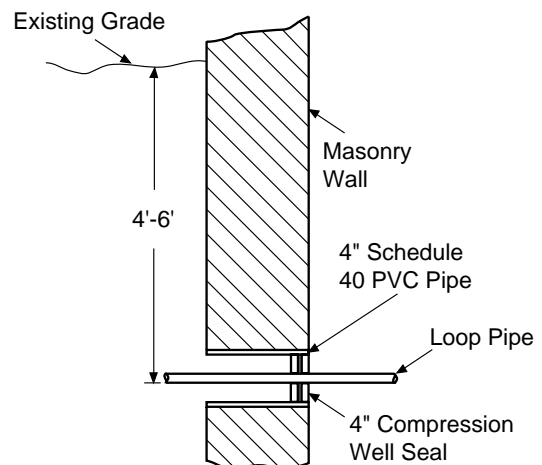

Loop Testing

Upon completion of the ground loop piping, pressure test the loop to assure a leak free system.

Parallel systems: Test Parallel systems as each leg is completed. Test again prior to the connection of the headers. Test the system for a final time when the entire loop is assembled and all legs are attached.

Series Systems: Test individual loops as installed. Test entire system when all loops are assembled.

Horizontal Systems: Test individual loops as installed. Test entire system when all loops are assembled.

Vertical U-Bends and Pool Loop systems: Test Vertical U-bends and pond loop assemblies prior to installation with a test pressure of at least 100 psi. Either water or air may be used as the testing medium.

Flushing, Purging, Adding Anti-Freeze, and Pressurizing the System

Upon completion of system installation and testing, flush the system to remove all foreign objects and purge to remove all air.

Refer to Section 7 of the IGSHPA manual for more information on flushing and purging Closed Loop Earth Coupled Systems.

Add antifreeze if necessary. Refer to the IGSHPA manual for the correct type and amount of antifreeze to add.

Refer to the IGSHPA Closed Loop Earth Coupled Systems Application Manual for complete instructions on flushing, purging, adding anti-freeze, and pressurizing the system.

WARNING

Do not use calcium chloride in ClimateMaster units. The use of calcium chloride voids the equipment warranty.

START-UP PREPARATION

Boiler/Cooling Tower System Cleaning and Flushing

Cleaning and flushing the unit is the single most important step to ensure proper start-up and continued efficient operation of the system.

Follow the instructions below to properly clean and flush the system:

⚠ WARNING ⚠

To prevent injury or death due to electrical shock or contact with moving parts, open unit disconnect before servicing unit.

1. Verify that electrical power to the units is disconnected.
2. Install the system with the supply hose connected directly to the return riser valve. Use a single length of flexible hose.
3. Open all air vents. Fill the system with water. Do not allow system to overflow. Bleed all air from the system. Check the system for leaks and repair appropriately.
4. Verify that all strainers are in place. Start the pumps and systematically check each vent to ensure that all air is bled from the system.
5. Verify that make-up water is available. Adjust make-up water appropriately to replace the air which was bled from the system. Check and adjust the water/air level in the expansion tank.
6. Set the boiler to raise the loop temperature to approximately 85° F. Open a drain at the lowest point in the system. Adjust the make-up water replacement rate to equal the rate of bleed.
7. Refill the system and add trisodium phosphate in a proportion of approximately one pound per 150 gallons of water. Reset the boiler to raise the loop temperature to about 100° F.

⚠ CAUTION

To avoid possible damage to piping systems constructed of plastic piping, DO NOT allow loop temperature to exceed 110° F.

Circulate the solution for a minimum of 8 to 24 hours. At the end of this period, shut off the circulating pump and drain the solution. Repeat system cleaning if desired.

8. When the cleaning process is complete, remove the short-circuited hoses. Re-connect the hoses to the proper supply and return the connections to each of

the Horizontal and Vertical units. Refill the system and bleed off all air.

9. Test the system pH with litmus paper. The system water should be slightly alkaline (pH 7.5 to 8.5). Add chemicals as appropriate to maintain acidity levels.

⚠ CAUTION

DO NOT use "Stop-Leak" or any similar chemical agent in this system. Addition of these chemicals to the loop water can foul the system and inhibit unit operation.

10. Check the main system panels, safety cutouts, and alarms after the system is successfully cleaned, flushed, refilled and bled. Set the controls to properly maintain loop temperatures.

Optional Hot Water Generator

When the unit is equipped with an optional hot water generator it will contain a coaxial tube-in-tube, vented double-wall heat exchanger.

⚠ CAUTION

To avoid equipment damage, DO NOT seal the vents located at each end of the coaxial coil.

Two (2) FPT connections are located on the front of the unit labeled "HWG IN" and "HWG OUT" which connect to the hot water generator.

Connect the heat exchanger as follows:

- 1) Plumb the unit to the water tank as described in the ClimateMaster Geo-Thermal Heat Pump Manual Volume 3.
- 2) Fill the system with water.
- 3) Purge the system of air.
- 4) Connect the blue wire to terminal 5 of the low voltage terminal board to activate the circulating pump. The circulating pump cycles with the compressor when there is a demand for hot water.

⚠ CAUTION

To avoid damage to the circulating pump, DO NOT connect the wire until plumbing is complete and the system is purged of air and filled with water.

SYSTEM CHECKOUT

When the installation is complete and the system is cleaned and flushed, follow the System Checkout procedure outlined below.

- 1. **Voltage:** Ensure that voltage is within the utilization range specifications of the unit compressor and fan motor.
- 2. **Wiring:** Ensure that fuses, breakers, and wire are sized correctly and that low voltage wiring is complete.
- 3. **Piping:** Ensure that piping is complete and water system is cleaned and flushed and that all air is purged from the water piping. Ensure that the condensate line is open, trapped, and correctly pitched.
- 4. **System Water Temperature:** Ensure that it is within an acceptable range to facilitate start-up. (When conducting this check, also verify proper heating and cooling set points.)
- 5. **System Water pH:** Verify system water acidity. (pH = 7.5 or 8.5) Proper pH promotes the longevity of hoses and heat exchangers.
- 6. **System Flushing:** Properly clean and flush system periodically. Ensure that all supply and return hoses are connected end-to-end to facilitate system flushing and prevent fouling of the heat exchanger by system water.
- 7. **System Water:** Water used in the system must be of potable quality and clean of dirt, piping slag, and chemical cleaning agents.
- 8. **System Return Air:** Ensure that return air temperature is between 50°-80°F in heating and 60°-95° F in cooling.
- 9. **Closed-Loop Cooling Tower** (Open Tower with Heat Exchanger): Check equipment for proper temperature set points and operation.
- 10. **Compressor:** Ensure that shipping blocks are removed and that compressor mounting bolts are loosened to reduce vibration noise.
- 11. **Water Flow:** Balance Water Flow Rate to Heat Pump.
- 12. **Standby Pump:** Verify that the standby pump is properly installed and in operating condition.
- 13. **System Controls:** To ensure that no catastrophic system failures occur, verify that system controls are functioning and that the sequencing is correct.
- 14. **Freeze Protection for Water System:** Verify that freeze protection is provided for the outdoor portion of the loop water system. Inadequate freeze protection can cause system operating problems.
- 15. **Site Temperature:** DO NOT allow the construction site to fall below freezing once the system is installed and tested. Condenser coils never fully drain by themselves and can freeze unless winterized with glycol.
- 16. **System Water Loop:** Verify that all air is bled from the system. Air in the system impedes unit operation and causes corrosion in the system piping.
- 17. **Unit Filters:** To avoid system damage, ensure that the unit filter is clean and in place.
- 18. **Unit Fans:** Manually rotate fans to assure free rotation. Ensure that fans are properly secured to the fan shaft. DO NOT oil fan motors on start-up since they are lubricated at the factory.
- 19. **System Control Center:** To ensure control of the temperature set-points for operation of the system's heat rejector and boiler, examine the system control and alarm panel for proper installation and operation.
- 20. **Cabinet:** Ensure that all cabinet panels are properly in place.
- 21. **Miscellaneous:** Note any questionable aspects of the installation.

UNIT START-UP

Use the procedure outlined below to initiate proper unit start-up:

⚡ WARNING ⚡

When the disconnect switch is closed, high voltage is present in some areas of the electrical panel. Exercise caution when working with energized equipment.

1. Turn thermostat fan position to "ON". Blower should start.
2. Balance air flow at registers.
3. Adjust all valves to their full open position. Turn on the line power to all heat pump units.
4. Operate unit in cooling cycle. Room temperature should be approximately 70° to 75° F DB, and 61° to 65° F WB. Loop water temperature entering the heat pumps should be between 70° F and 110° F.
5. Three factors determine the operating limits of a Horizontal and Vertical unit: (a) return air temperature, (b) water temperature, and (c) ambient temperature. When any one of these factors is at a minimum or maximum level, the other two factors must be at normal levels to ensure proper unit operation.
 - a. Adjust the unit thermostat to the cooling position. Slowly reduce thermostat setting until the water control valve/loop pump(s) activates.
 - b. Check for cool air delivery at a system grille within a few minutes after the unit has begun to operate.

NOTE: Units have a 5 minute time delay in the control circuit.

 - c. Verify that compressor is on and that the water flow rate is correct by measuring pressure drop thorough the heat exchanger using the Pete's plugs and comparing to the heat pump specification sheet.
 - d. Check the elevation and cleanliness of the condensate lines. Dripping may be a sign of a blocked line.
 - e. Check the temperature of both supply (refer to Table 4) and discharge water. If temperature differential (refer to Table 4) is within rage, proceed with test. If temperature is outside operating range, check cooling refrigerant pressures.
 - f. Check air temperature drop across the coil with the compressor operating. Air temperature should drop between 16° F and 20° F.
6. Operate the heat pump in the heating cycle immediately after checking cooling cycle operation.

Allow five (5) minutes between tests for pressure to equalize.

- a. Turn thermostat to lowest setting and set thermostat switch to "HEAT" position.
 - b. Slowly turn thermostat to a higher temperature until water control valve/loop pumps activates.
 - c. Check for warm air delivery at a system grille within a few minutes after the unit has begun to operate.
 - d. Check the temperature of both supply (refer to Table 4) and discharge water. If temperature differential (refer to Table 4) is within range, proceed with test. If temperature is outside operating range, check heating refrigerant pressures.
 - e. Check air temperature rise across the coil when both compressors are operating. Air temperature should rise between 25° F and 35° F.
 - f. If auxiliary heat is used, turn thermostat to highest setting. Assure that auxiliary electric heat activates. Check for proper temperature rise across the heater.
 - g. Verify that all stages of auxiliary heat (if used) activate when the thermostat is set in "EMERGENCY HEAT" position.
 - h. Check for vibration, noise, and water leaks.
7. If unit fails to operate, perform System Checkout (page 14). If the check described fails to reveal the problem and the unit still does not operate, contact a trained service technician to ensure proper diagnosis and repair of the equipment.
 8. When testing is complete, set system to maintain desired comfort level.

Table 4: Water Temperature Change Through Heat Exchanger

Water Flow Rate (GPM)	Rise	Drop
Closed Loop*	9°F - 12° F	4°F - 8°F
Open Loop**	10°F Max	4°F - 8°F

* Earth Coupled or Cooler/Boiler System use 3 GPM/ton

** Flow rate adjusted for temperature

MAINTENANCE

Maintenance Procedures

Perform the maintenance procedures outlined below periodically as indicated.

⚠ WARNING ⚠

To prevent injury or death due to electrical shock or contact with moving parts, open unit disconnect switch before servicing unit.

FILTERS: Inspect filters. Establish a regular maintenance schedule. Replace/clean filter frequently depending upon need.

To remove the filter from a Horizontal and Vertical unit, slide the filter out of its frame located in the return air opening at the bottom front of the unit. When re-installing the filter, use the slide-in rails of the filter frame to guide the filter into the proper position.

⚠ CAUTION

CAUTION: To avoid fouled machinery and extensive unit clean-up, do not operate units without filters in place. Do not use equipment as a temporary heating or cooling source during construction.

CONDENSATE PANS: Check condensate drain pans for algae growth every three months. If algae growth is apparent, consult a water treatment specialist for proper chemical treatment. The application of an algaecide every three months typically eliminates algae problems in most locations.

FAN MOTORS: All units have fully lubricated fan motors. DO NOT lubricate.

Conduct amperage checks annually. Amperage draw should not exceed normal full load or rated load amps by more than 10% of the values noted on the unit nameplate. Maintain a log of amperage values to detect deterioration prior to component failure.

UNIT INSPECTION: Visually inspect the unit annually. Pay special attention to hose assemblies. Repair any leaks and replace deteriorated hoses immediately.

COMPRESSOR: Conduct an amperage check on the compressor annually. Amperage draw should not exceed normal full load or rated load amps by more than 10% of

the values noted on the unit nameplate. Maintain a log of amperage values to detect deterioration prior to component failure.

⚠ WARNING

When replacing the compressor contactor or lockout relay in a unit with electromechanical controls, use only ClimateMaster replacement parts. Substitution of other components may result in an inoperative safety circuit and may cause a hazardous condition.

HEAT EXCHANGERS: Clean heat exchangers annually. Inspect heat exchangers regularly and clean more frequently if the unit is located in a "dirty" environment.

Safety Control Reset

All ClimateMaster Horizontal and Vertical units are furnished with High and Low pressure cutouts to prevent the machine from operating at abnormal or damaging temperature or water flow conditions.

The contacts of the high-pressure control used on units are designed to open at 380 psig and automatically close at 300 psig. The contacts of the high temperature switch open at 200° F and close at 160° F. The contacts of the low-temperature switch open at 21° F and re-close at 31°F. The high level condensate device activates when moist and deactivates when dry. A lockout circuit, electrically linked with these cutouts, interrupts unit operation. The unit must be reset manually.

On units with solid state controllers, the control board indicates which safety resulted in the lockout. The unit attempts to restart ten (10) minutes after the first trip.

Note: If the unit must be reset, check the unit for a dirty filter, abnormal entering water temperature, inadequate or excessive water flow, and internal malfunction. If the unit continues to cutout, contact a trained service technician.



Part #69197308



7300 S.W. 44th Street
Oklahoma City, OK 73179
Phone: 405-745-6000
Fax: 405-745-6058
www.climatemaster.com

ClimateMaster works continually to improve its products. As a result, the design and specifications of each product at the time of order may be changed without notice and may not be as described herein. Please contact ClimateMaster's Customer Service Department at 1-405-745-6000 for specific information on the current design and specifications. Statements and other information contained herein are not express warranties and do not form the basis of any bargain between the parties, but are merely ClimateMaster's opinion or commendation of its products.